

CITY OF SAUSALITO, CALIFORNIA
**BRIDGEWAY AND CALEDONIA STREET
 SERIES STREETLIGHT CIRCUIT CONVERSION**

MAY 2013

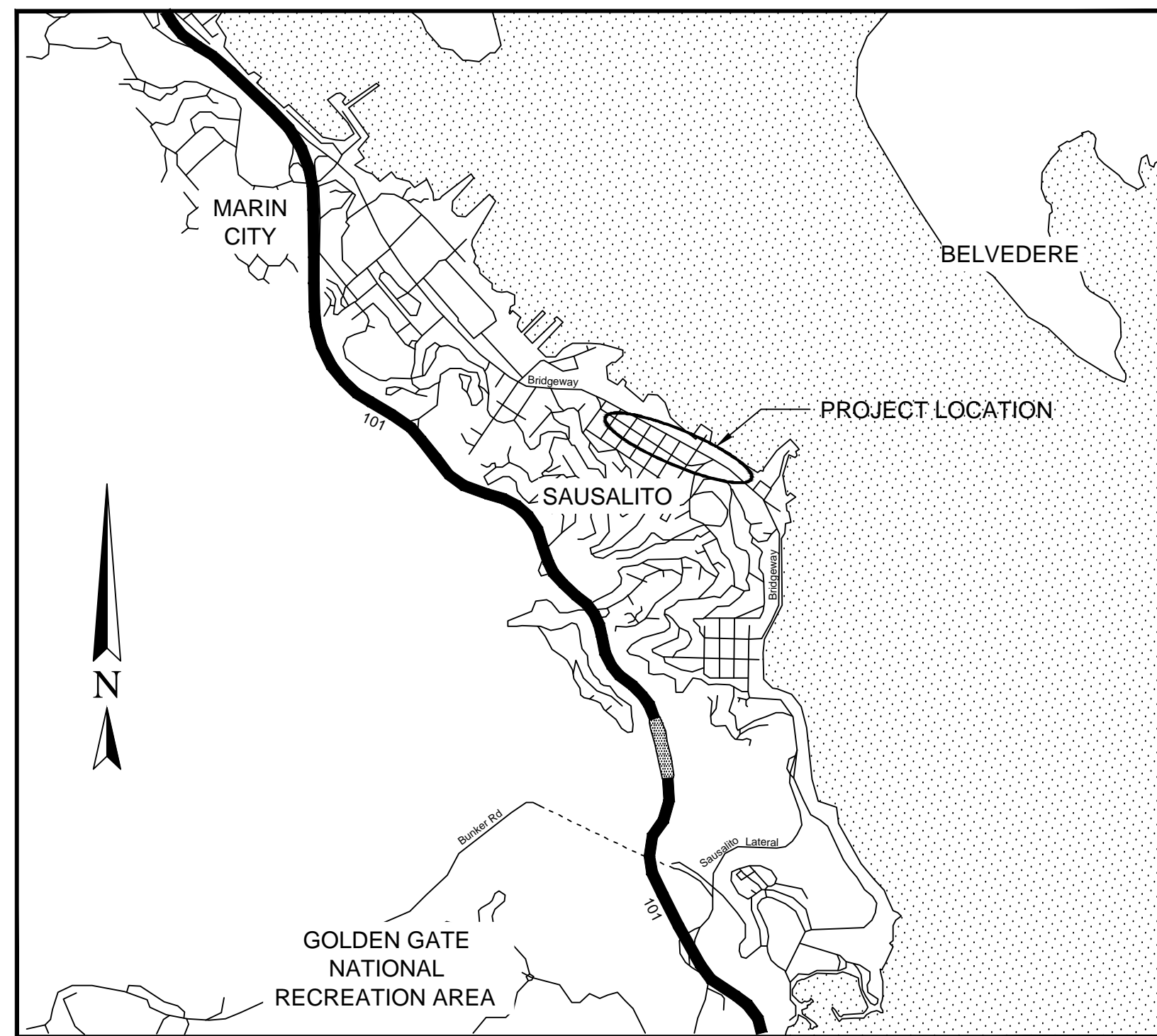

LOCATION MAP

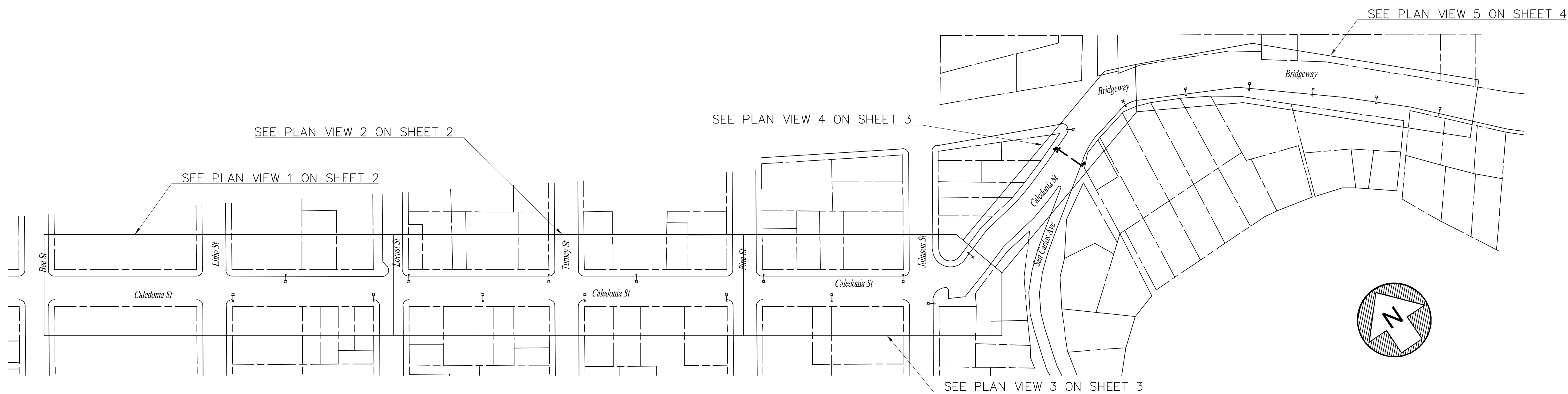

SITE MAP
 1"=100'

BEFORE EXCAVATING CALL
 UNDERGROUND SERVICE ALERT
 AT LEAST 48 HOURS IN ADVANCE

 USA NORTH
 1-800-227-2600

CITY OF SAUSALITO
 DEPARTMENT of PUBLIC WORKS

SIEMENS
 Road and City Mobility
 3765 Yale Way
 Fremont, CA 94538
 Tel: +1 (510) 440-8127

REV	DESCRIPTION OF REVISION	BY	DATE

BRIDGEWAY AND CALEDONIA STREET SERIES CIRCUIT CONVERSION

TITLE SHEET

WARNING

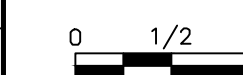

IF THIS BAR DOES NOT MEASURE 1" THEN DRAWING IS NOT TO SCALE



DESIGN MTK SCALE NA DATE 5/13/13 SHEET 1/5
 DRAWN MTK
 CHECKED APPROVED REVISION

REVISION

GENERAL NOTES

- ALL IMPROVEMENTS SHALL BE CONSTRUCTED IN ACCORDANCE WITH THESE PLANS, THE STATE OF CALIFORNIA STANDARD SPECIFICATIONS, STANDARD PLANS, AND THE PROJECT SPECIAL PROVISIONS. EXACT FIELD LOCATIONS FOR NEW IMPROVEMENTS SHALL BE APPROVED BY THE ENGINEER BEFORE CONSTRUCTION.
- IF THE CONTRACTOR IS UNABLE TO INSTALL NEW CONDUCTORS IN AN EXISTING CONDUIT DUE TO POOR CONDUIT CONDITION, THE CONTRACTOR SHALL DETERMINE THE LOCATION AND LENGTH OF THE CONDUIT RUN THAT REQUIRES REPLACEMENT. THE CONTRACTOR SHALL ALSO DETERMINE WHETHER THE ENDS OF THE CONDUIT TERMINATE INTO EXISTING PULL BOXES OR DIRECTLY INTO A POLE FOUNDATION. THE CONTRACTOR SHALL NOTIFY THE CITY ENGINEER OF THE REQUIRED CONDUIT REPLACEMENT. UPON APPROVAL BY THE CITY ENGINEER THE CONTRACTOR SHALL INSTALL NEW CONDUIT TO REPLACE THE UNUSABLE CONDUIT.
- NEW CONDUIT MAY BE INSTALLED BY DIRECTIONAL BORE OR TRENCHING IN PAVEMENT METHODS. IF TRENCHING IN PAVEMENT METHOD IS USED THE "T-TRENCH" DETAIL ON SHEET 5 SHALL APPLY.
- IF AN EXISTING CONDUIT THAT IS TO BE REPLACED TERMINATES INTO AN EXISTING PULL BOX, THE REPLACEMENT CONDUIT SHALL ALSO TERMINATE INTO THE SAME PULL BOX.
- IF AN EXISTING CONDUIT THAT IS TO BE REPLACED TERMINATES DIRECTLY INTO A POLE FOUNDATION, THE REPLACEMENT CONDUIT SHALL ALSO TERMINATE DIRECTLY INTO THE EXISTING FOUNDATION BY INTERCEPTING AND CONNECTING TO THE EXISTING CONDUIT AS NEAR TO THE POLE FOUNDATION AS PRACTICAL.
- ALL EXISTING CONDUIT IS RIGID METAL TYPE. IF CONDUIT NEEDS TO BE REPLACED IT SHALL BE REPLACED IN KIND.

CONSTRUCTION NOTES*

- EXISTING 1-1/2" C, 1#6 (SSL). REMOVE 1#6 (SSL). INSTALL 1#8 (120V SLA), 1#8 (SLN), 1#8 (GND).
- EXISTING 1-1/2" C, 1#6 (SSL). REMOVE 1#6 (SSL). INSTALL 1#8 (120V SLA), 1#8 (120V SLB), 1#8 (SLN), 1#8 (GND).
- EXISTING 1-1/2" C, 1#6 (SSL). REMOVE 1#6 (SSL). INSTALL 1#6 (120V SLA), 1#8 (120V SLB), 1#6 (SLN), 1#8 (GND).
- EXISTING 1-1/2" C, 1#6 (SSL). REMOVE 1#6 (SSL). INSTALL 1#6 (120V SLA), 1#6 (120V SLB), 1#6 (SLN), 1#8 (GND).
- EXISTING 1-1/2" C, 1#6 (SSL). REMOVE 1#6 (SSL). INSTALL 1#8 (120V SLC), 1#8 (SLN), 1#8 (GND).
- EXISTING 1-1/2" C, 1#6 (SSL). REMOVE 1#6 (SSL). INSTALL 1#8 (120V SLC), 1#8 (120V SLD), 1#8 (SLN), 1#8 (GND).
- EXISTING 1-1/2" C, 1#6 (SSL). REMOVE 1#6 (SSL). INSTALL 1#6 (120V SLC), 1#8 (120V SLD), 1#6 (SLN), 1#8 (GND).
- EXISTING 1-1/2" C, 2#6 (SSL). REMOVE 2#6 (SSL). INSTALL 1#6 (120V SLA), 1#6 (120V SLB), 1#6 (120V SLC), 1#8 (120V SLD), 2#6 (SLN), 1#8 (GND).
- EXISTING 1-1/2" C, 2#6 (SSL). REMOVE 2#6 (SSL). INSTALL 1#10 (120V SLE), 1#10 (SLN), 1#8 (GND).
- EXISTING 1-1/2" C, 2#6 (SSL). REMOVE 2#6 (SSL). INSTALL 1#10 (120V SLE), 1#10 (120V SLF), 1#10 (SLN), 1#8 (GND).
- NEW 2" C. INSTALL 2#2 (120V SERVICE).
- PG&E TO REMOVE EXISTING SERVICE CONNECTION FOR SERIES STREET LIGHT CIRCUIT. PG&E TO INSTALL NEW SERVICE CONNECTION FOR 120V STREET LIGHTING.
- LEAVE 2' OF 2#2 SERVICE CONDUCTORS COILED IN PULL BOX. PG&E TO SPLICE TO NEW SERVICE CONNECTION.
- FURNISH AND INSTALL NEW TYPE III-AF SERVICE ENCLOSURE. SEE SERVICE WIRING DIAGRAM ON SHEET 5.
- INSTALL CITY FURNISHED STREET LIGHT FIXTURE ON EXISTING POLE.
- FURNISH AND INSTALL PHOTOELECTRIC UNIT ON TOP OF EXISTING POLE.

*SSL = SERIES STREET LIGHT CIRCUIT
 SLA = STREET LIGHT CIRCUIT A
 SLB = STREET LIGHT CIRCUIT B
 SLC = STREET LIGHT CIRCUIT C
 SLD = STREET LIGHT CIRCUIT D
 SLE = STREET LIGHT CIRCUIT E
 SLF = STREET LIGHT CIRCUIT F
 SLN = STREET LIGHT NEUTRAL

LEGEND

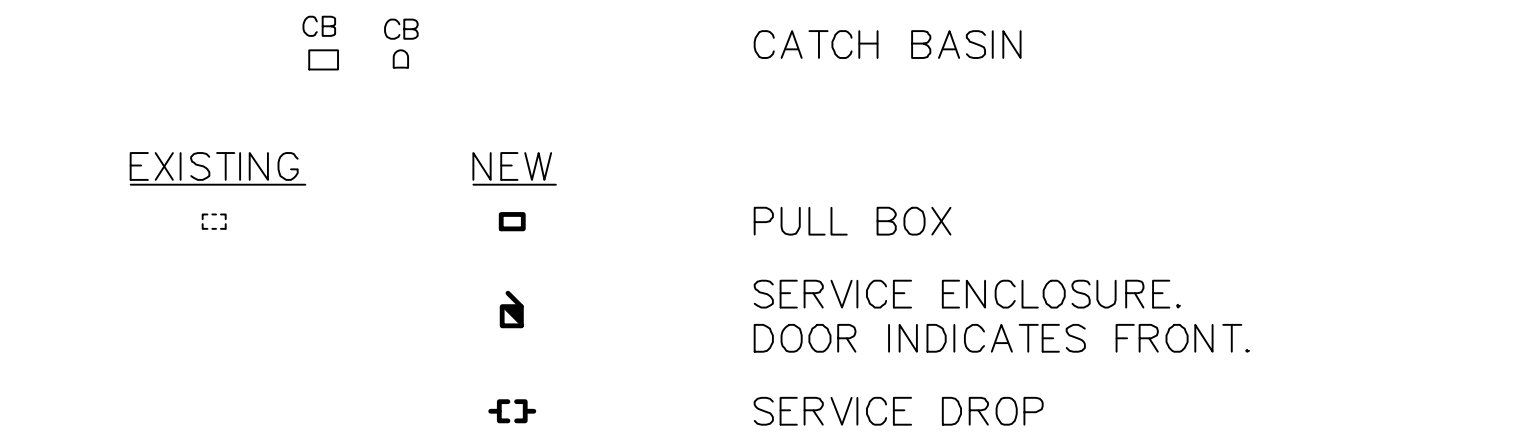
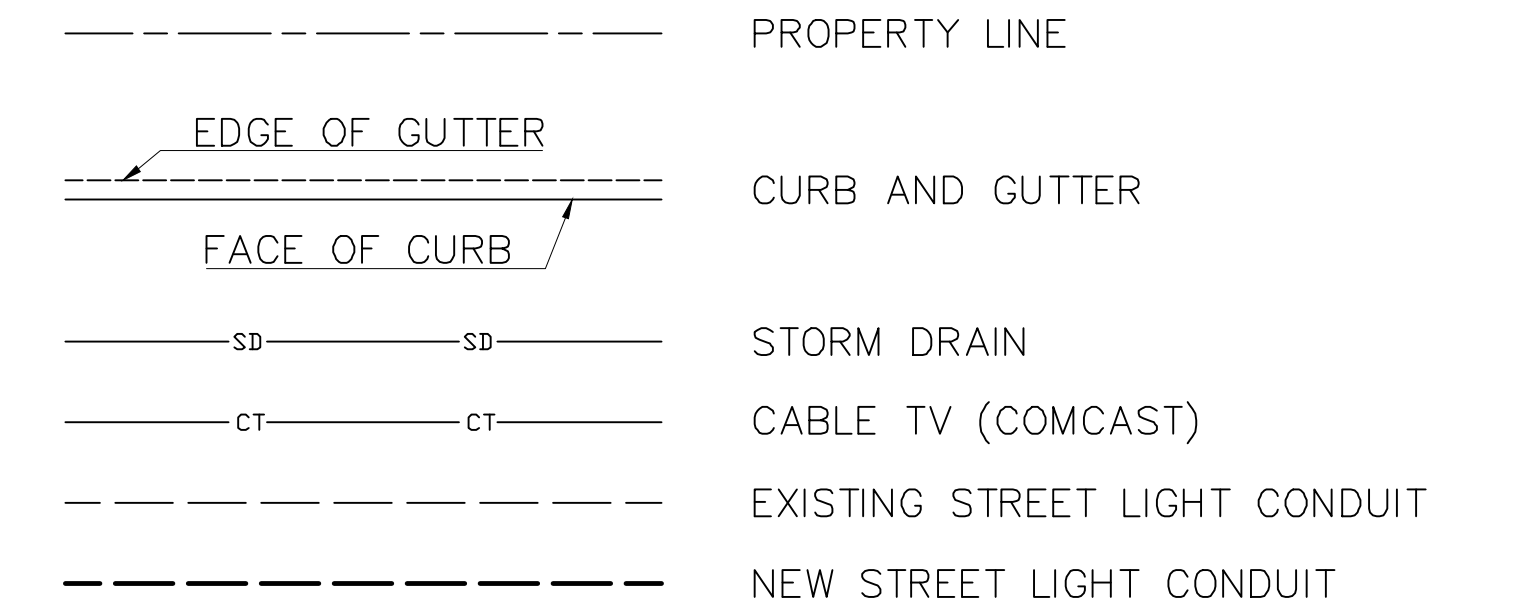

- AB ABANDON. IF APPLIED TO CONDUIT, REMOVE CONDUCTORS.
- CC CONNECT NEW AND EXISTING CONDUIT. REMOVE EXISTING CONDUCTORS AND INSTALL CONDUCTORS AS INDICATED.
- 3 PROJECT NOTE. NUMBER INDICATES NOTE NUMBER.

CITY OF SAUSALITO
 DEPARTMENT of PUBLIC WORKS

SIEMENS
 Road and City Mobility
 3765 Yale Way
 Fremont, CA 94538
 Tel: +1 (510) 440-8127

REV	DESCRIPTION OF REVISION	BY	DATE

BRIDGEWAY AND CALEDONIA STREET SERIES CIRCUIT CONVERSION

NOTES

WARNING
 0 1/2 1
 IF THIS BAR DOES NOT MEASURE 1" THEN DRAWING IS NOT TO SCALE

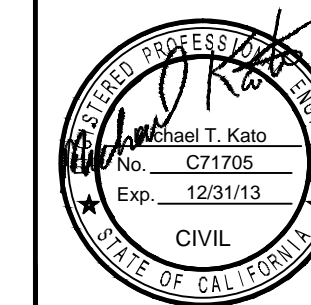

DESIGN MTK	SCALE NA	DATE 5/9/13	SHEET 2
DRAWN 5/13/13	CHECKED	APPROVED	5

REVISION

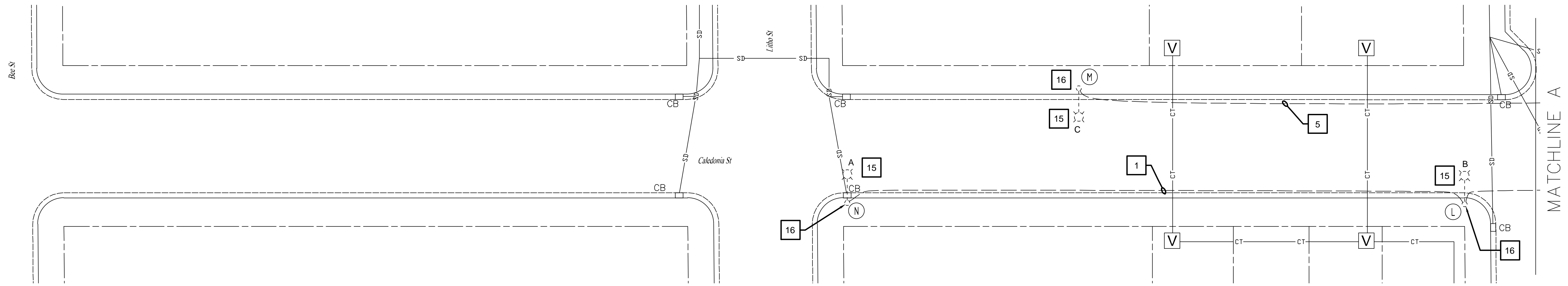

PLAN VIEW 1
 CALEDONIA STREET
 FROM BEE STREET TO LOCUST STREET
 1" = 20'

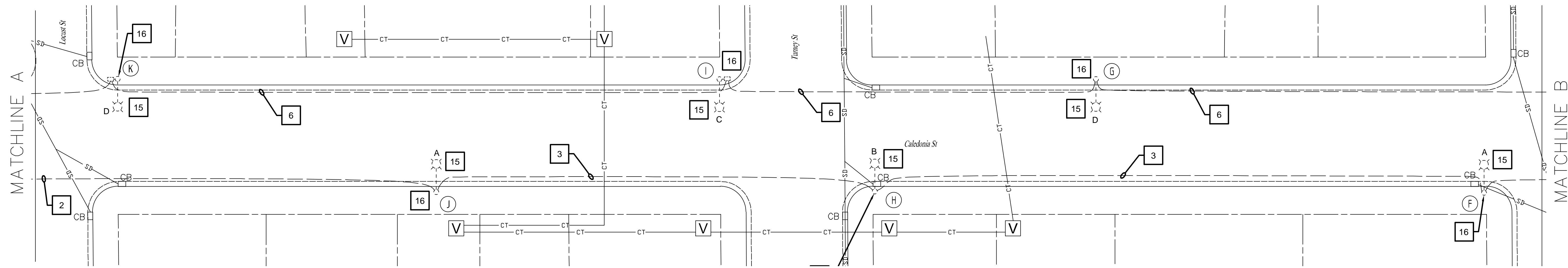
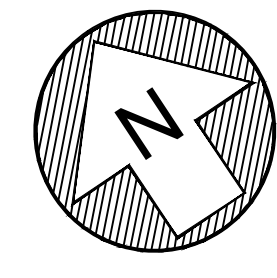

PLAN VIEW 2
 CALEDONIA STREET
 FROM LOCUST STREET TO PINE STREET
 1" = 20'

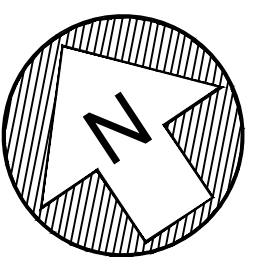

CITY OF SAUSALITO
 DEPARTMENT of PUBLIC WORKS

SIEMENS
 Road and City Mobility
 3765 Yale Way
 Fremont, CA 94538
 Tel: +1 (510) 440-8127

REV	DESCRIPTION OF REVISION	BY	DATE

BRIDGEWAY AND CALEDONIA STREET SERIES CIRCUIT CONVERSION
 ELECTRICAL
 STREETLIGHT PLAN

WARNING
 0 1/2 1
 IF THIS BAR DOES NOT MEASURE 1" THEN DRAWING IS NOT TO SCALE

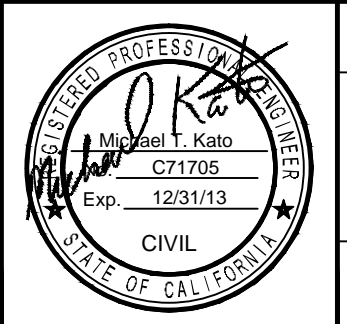

DESIGN MTK	SCALE 1" = 20'	DATE 5/13/13	SHEET 3
DRAWN MTK	APPROVED		5
CHECKED			REVISION

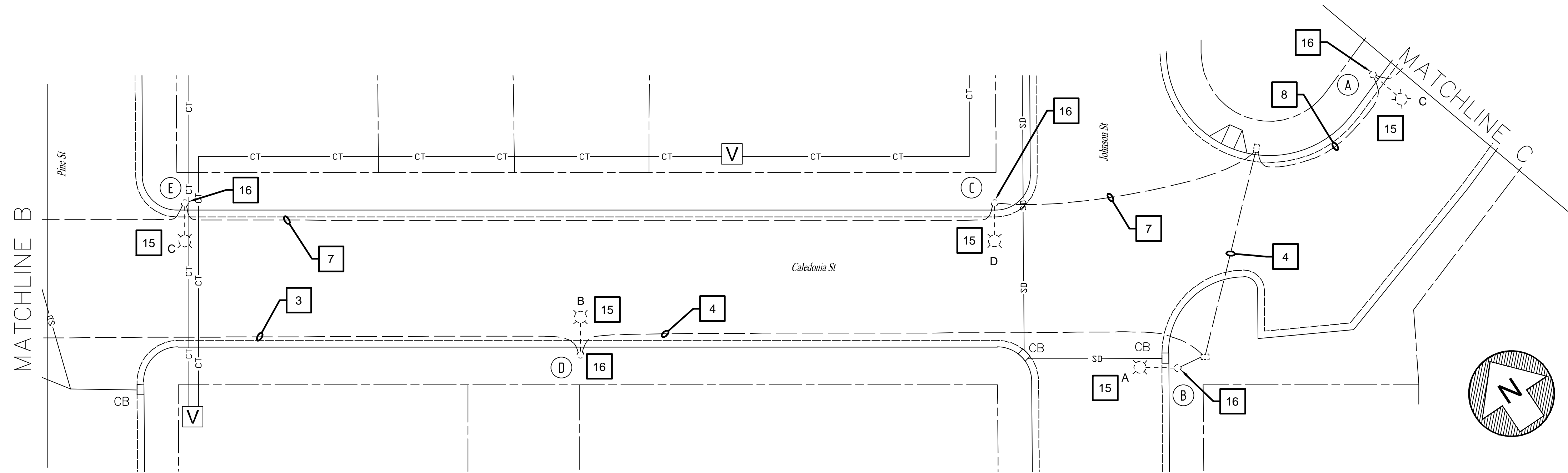

PLAN VIEW 3
 CALEDONIA STREET
 FROM PINE STREET TO 100 FEET EAST OF JOHNSON STREET
 1"=20'

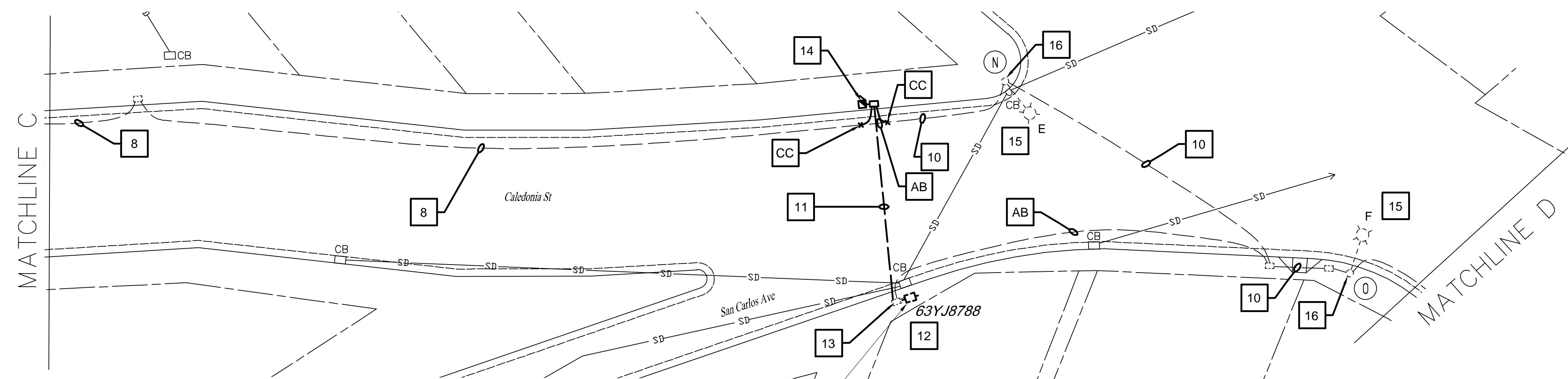

NEW SERVICE
 NEW LOAD:
 21 - 150 W HPS LUMINAIRES (UNMETERD)
 2100 W FOR FUTURE USE (METERED)

PLAN VIEW 4
 CALEDONIA STREET
 FROM 100 FEET EAST OF JOHNSON STREET TO BRIDGEWAY
 1"=20'

CITY OF SAUSALITO
 DEPARTMENT of PUBLIC WORKS

SIEMENS
 Road and City Mobility
 3765 Yale Way
 Fremont, CA 94538
 Tel: +1 (510) 440-8127

REV	DESCRIPTION OF REVISION	BY	DATE

BRIDGEWAY AND CALEDONIA STREET SERIES CIRCUIT CONVERSION

ELECTRICAL
 STREETLIGHT PLAN

WARNING

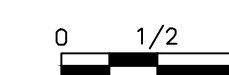

IF THIS BAR DOES NOT MEASURE 1" THEN DRAWING IS NOT TO SCALE

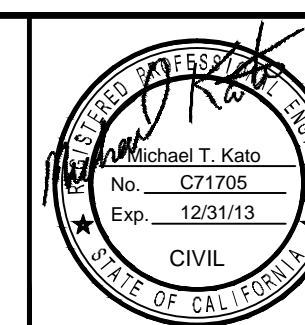

DESIGN MTK SCALE 1" = 20' DATE 5/13/13 SHEET 4
 DRAWN MTK
 CHECKED _____ APPROVED _____ REVISION 5

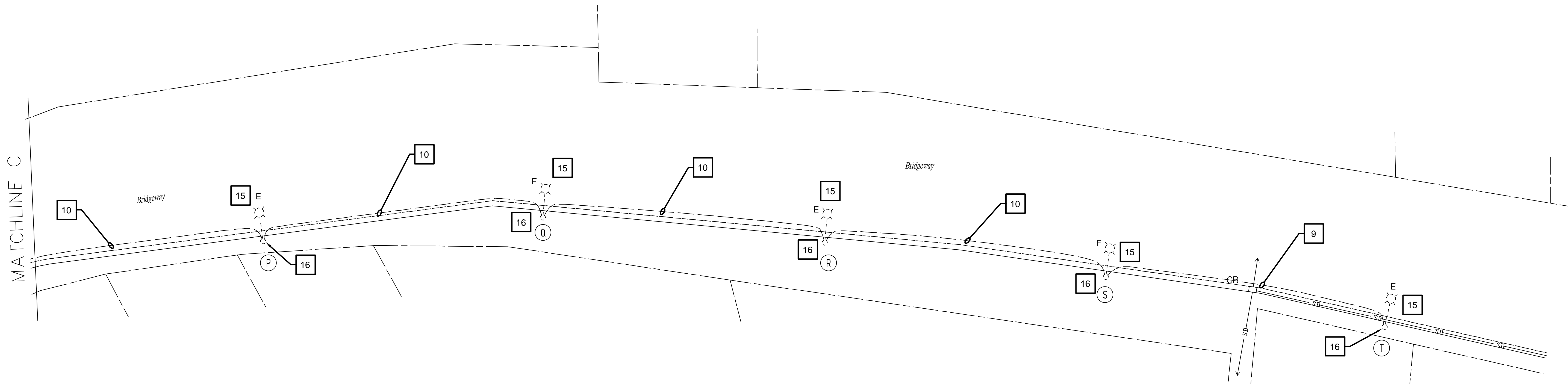

**PLAN VIEW 5
BRIDGEWAY**
FROM CALEDONIA STREET TO 550 FEET EAST OF CALEDONIA STREET
1"=20'

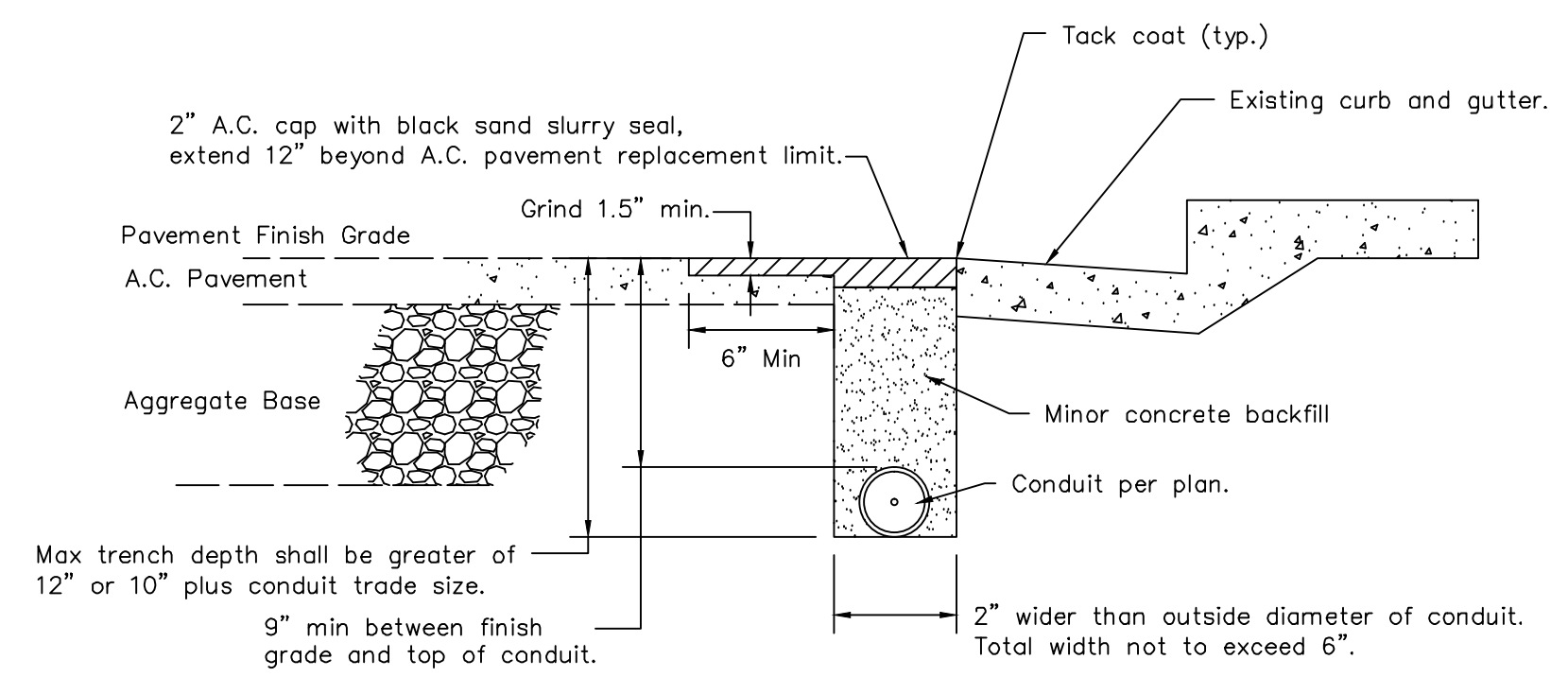
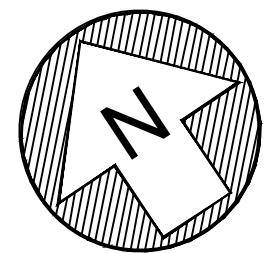

- Notes:
1. Grind existing A.C. min 1.5" deep by min. 6" wide on street side of trench after conduit is installed.
 2. Minor concrete backfill shall contain a minimum of 590 lbs of cementitious material per cubic yard.

TRENCH AT LIP OF GUTTER
NO SCALE

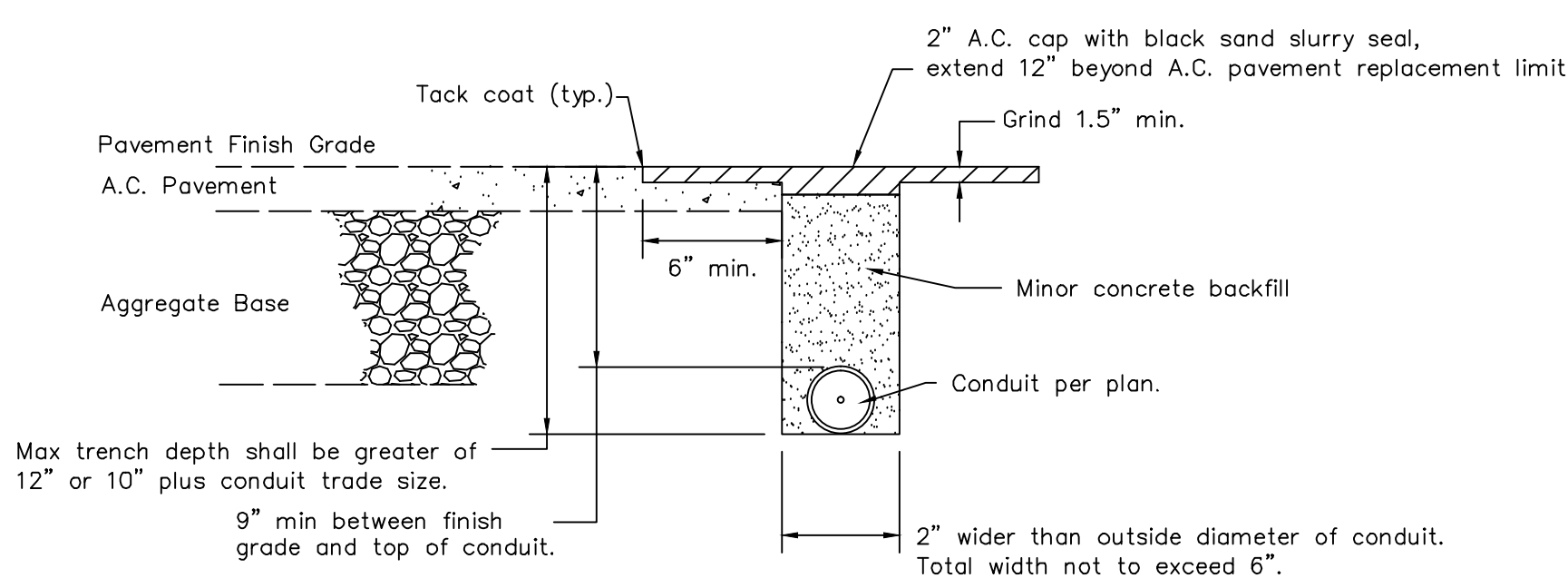

- Notes:
1. Grind existing A.C. min 1.5" deep by min. 6" wide on street side of trench after conduit is installed.
 2. Minor concrete backfill shall contain a minimum of 590 lbs of cementitious material per cubic yard.

TRENCH IN ROADWAY
NO SCALE

TYPE III-A SERVICE (120/240V) EQUIPMENT LEGEND		
ITEM NO.	COMPONENT	NAME PLATE DESCRIPTION
1	NEUTRAL LUG	
2	LANDING LUG (NOTE 6)	
3	TEST BYPASS FACILITY	
4	METER SOCKET AND SUPPORT	
5	NEUTRAL BUS	
6	GROUND BUS	
7	GROUNDING ELECTRODE	
8	100 A, 240 V, 3P, CB	MAIN BREAKER
9	25 A, 120 V, 1P, CB	LIGHTING
10	20 A, 120 V, 1P, CB	FUTURE USE

- NOTES: (FOR SERVICE EQUIPMENT ENCLOSURE)
1. ITEMS NO. 1 AND 2 SHALL BE ISOLATED FROM THE SERVICE EQUIPMENT ENCLOSURE.
 2. METER SOCKETS SHALL BE 5 CLIP TYPE.
 3. THE LANDING LUG SHALL BE SUITABLE FOR MULTIPLE CONDUCTORS.
 4. TYPE IV PHOTOELECTRIC CONTROL SHALL BE USED.

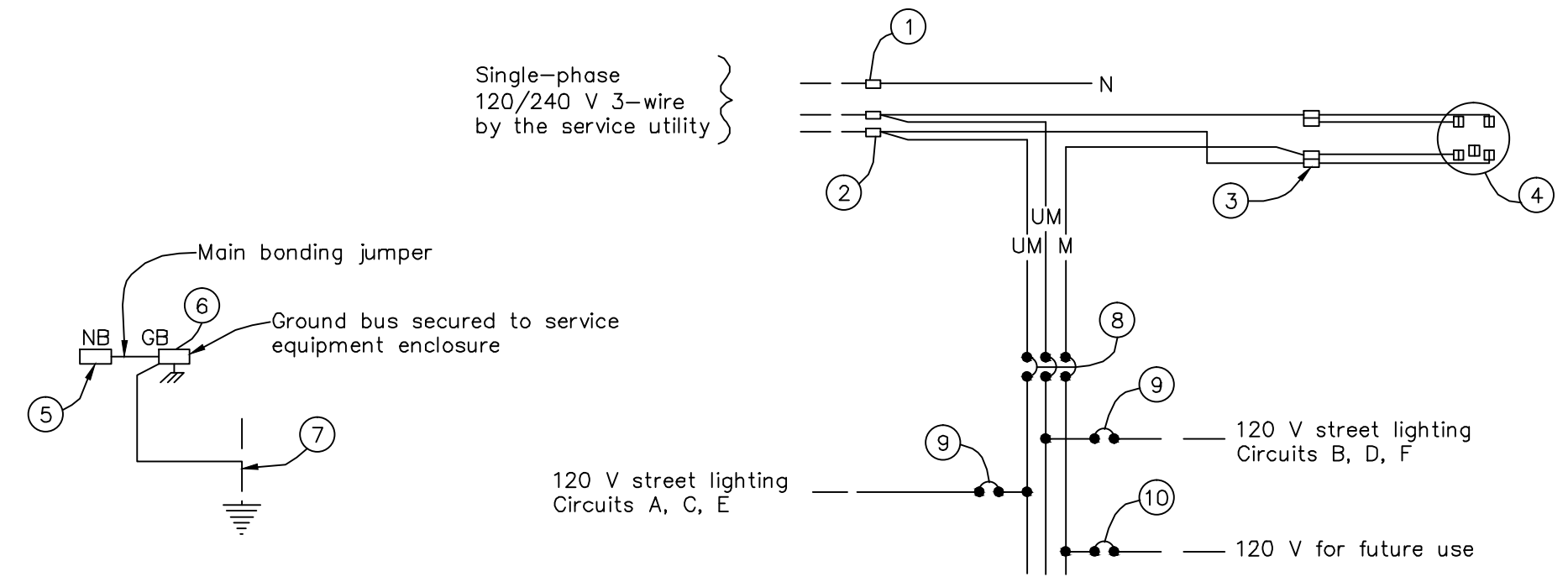

120/240 V SERVICE WIRING DIAGRAM

- WIRING DIAGRAM LEGEND
- P POLE
 - CB CIRCUIT BREAKER
 - A AMPERE
 - V VOLT
 - M METERED
 - UM UNMETERED
 - NB NEUTRAL BUS
 - GB GROUND BUS
 - N GROUNDED CIRCUIT CONDUCTOR (NEUTRAL)
 - EXTERNAL CONDUCTOR OR BUS
 - CONDUCTOR TIE POINT
 - ENCLOSURE BOND
 - GROUNDING ELECTRODE
 - CIRCUIT BREAKER

CITY OF SAUSALITO
DEPARTMENT of PUBLIC WORKS

SIEMENS
Road and City Mobility
3765 Yale Way
Fremont, CA 94538
Tel: +1 (510) 440-8127

REV	DESCRIPTION OF REVISION	BY	DATE

BRIDGEWAY AND CALEDONIA STREET SERIES CIRCUIT CONVERSION
ELECTRICAL
STREETLIGHT PLAN

WARNING
0 1/2 1
IF THIS BAR DOES NOT MEASURE 1" THEN DRAWING IS NOT TO SCALE

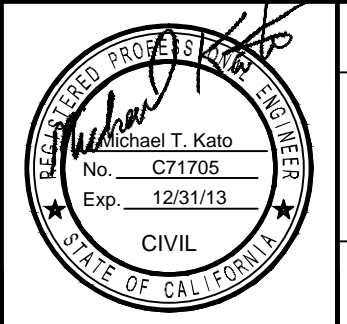

DESIGN MTK SCALE 1" = 20' DATE 5/13/13 SHEET 5
DRAWN MTK APPROVED
CHECKED _____ REVISION