

## Bid Package 4B – Bridgeway South

### List of Documents in Bid Package:

- General Notes
- List of Items
- Maps showing item locations
- Item details (plans)
- Caltrans Revised Standard Plan RSP A88A dated March 21, 2014
- Estimated Quantities
- Specifications

**City of Sausalito Accessibility Improvement Project**  
**Bid Package #4B - Bridgeway South**  
**GENERAL NOTES**

**Notes apply to all details and plans for Accessibility Improvement Project 2015**

1. The naming convention for the items on the list, such as BW 15-02, is as follows:
  - a. BW – location = Bridgeway
  - b. 15 - Map # = Map 15
  - c. 02 – Item # = number in square on relevant map
  
2. For new curb ramps, reference Caltrans RSP A88A dated March 21, 2014. For new sidewalks and curb and gutter reference Dwg. 105, Marin County Uniform Construction Standards dated May 2008.
  
3. For orientation purposes related to components of new curb ramps on the Plans, the terms “right” and “left” are used as if you are viewing the Caltrans RSP A88A, or standing in the street facing the curb ramp.
  
4. The finishes of all new concrete curb ramps, sidewalk and associated flatwork shall match the existing adjacent concrete finishes as closely as practicable. In every location, this will involve some level of washing the new concrete surface to expose some aggregate to match adjacent concrete finish, as noted in the Estimated Quantities matrix. In some locations, the finish will include an approved seeded aggregate to match existing adjacent surfaces. All concrete washing water shall be immediately vacuumed and shall not be allowed to enter storm drains or adjacent property. The 12” groove borders of new ramps shall be brush finished. New curb and gutter and miscellaneous retaining curbs shall be light broom finished.
  
5. All new ADA ramps shall have a maximum running slope of **8.3%** and maximum cross slope of **2%**. All new ADA landings shall have a maximum slope of **2%** in all directions. (slightly different than Caltrans Standard Plan RSP A88A).
  
6. Detectable warning tiles on new curb ramps shall be Armor-Tile ADA-C Detectable-Tactile Warning Surface Tiles, yellow color no. 33538 of FED-STD-395, unless noted otherwise on the Plans. When Brick Red color is specified, use color no. 22144. Install per dimensions specified in notes 10 and 11 of Caltrans RSP A88A dated March 21, 2014, or as shown on the Plans. Curb ramps shall have a detectable warning surface that extends the full width of the ramp (Cases A and F) or the lower landing (Case C) and 3 foot depth.

**City of Sausalito Accessibility Improvement Project**  
**Bid Package #4B - Bridgeway South**  
**GENERAL NOTES**

7. Contractor shall install dowels between all new concrete and existing adjacent concrete. Dowels shall be #4 rebar @ 24" on center, installed 6" into existing concrete and 6" into new concrete.
8. There shall be no lip at the bottom of new ramp (Case A) or new lower landing (Case F and Case C) where it meets the gutter. Smooth transitions only. Existing curb and gutter shall be removed and replaced adjacent to all new ramps, flares, landings, and transition areas, or as shown on the Plans.
9. Installation of all new curb and gutter shall maintain adequate slope at flow line (minimum 1%) in direction of water flow.
10. Estimated quantities for new curb and gutter include a minimum 24 inch gutter pan for the entire length of the curb ramp case selected, including new ramps, flares, landings, transition areas, and ramps. New curb and gutter in front of the ramp (Cases A and F) or lower landing of the curb ramp detail (Case C) shall have a maximum slope of 5% in the direction of path of travel (also referred to as running direction). Gradually transition this 5% gutter pan slope to conform to existing adjacent curb and gutter configuration over the remaining length of the new curb and gutter.
11. Installation of all new curb and gutter shall include removal and replacement of adjacent asphaltic concrete roadway in an amount necessary to create a smooth transition from new gutter to existing asphalt concrete roadway. The estimated quantities include a 24 inch wide removal and replacement of AC pavement (from lip of gutter) to conform new 5% max cross slope gutter to existing AC roadway. If additional or less AC removal and replacement is approved by the City, payment shall be adjusted at unit cost. New asphalt concrete roadway shall match existing adjacent thickness, but shall not be less than 6 inches in thickness.
12. Contractor shall coordinate with various utility companies for adjustment of utility boxes to align with new concrete grades.
13. Contractor shall install an approved bond breaker between all new concrete and adjacent buildings and structures.
14. The details provided for each item are diagrammatic and not-to-scale. Contractor shall field verify all measurements and slopes provided by the Plans and notify the City if

**City of Sausalito Accessibility Improvement Project**  
**Bid Package #4B - Bridgeway South**  
**GENERAL NOTES**

there are any locations where slopes as specified cannot be achieved. Contractor shall arrange for City inspection of forms before pouring concrete.

15. Contractor shall sawcut existing concrete and AC pavement as necessary. All sawcutting shall use water to control dust and all slurry generated from sawcutting shall be immediately vacuumed from surfaces and removed from site.
16. Contractor shall notify business owners affected by work at least 72 hours before start of work and shall maintain minimum 48 inches access to businesses.

**Bid Package 4B**  
**List of Items**

<b>Item #</b>	<b>Location</b>
<b>BW 15-02</b>	Bridgeway/Napa St., SE
<b>BW 15-03</b>	Bridgeway/Napa St., NE
<b>BW 15-07</b>	Bridgeway/Off Ramp to Napa St., West
<b>BW 15-08</b>	Bridgeway/Off Ramp to Napa St., East
<b>BW 15-09</b>	Bridgeway/Napa St., NW
<b>BW 15-10</b>	Bridgeway/Napa St., SW
<b>BW 16-03</b>	Bridgeway/Bee St., SE
<b>BW 18-03</b>	Bridgeway/Locust St., NW
<b>BW 18-04</b>	Bridgeway/Locust St., NW
<b>BW 18-05</b>	Bridgeway/Locust St., SW
<b>BW 20-02</b>	Bridgeway/Pine St., SE
<b>BW 20-03</b>	Bridgeway/Pine St., NE
<b>BW 20-08</b>	Bridgeway/Pine St., NW
<b>BW 20-09</b>	Bridgeway/Pine St., SW
<b>BW 21-02</b>	Bridgeway/Johnson St., SE
<b>BW 21-04</b>	Bridgeway/Johnson St., NE
<b>BW 21-12</b>	Bridgeway/Johnson St., SW
<b>BW 22-08</b>	Bridgeway/Caledonia St., NW
<b>BW 22-09</b>	Bridgeway/Caledonia St., SW
<b>PSP-05</b>	Pine/Caledonia St., NE

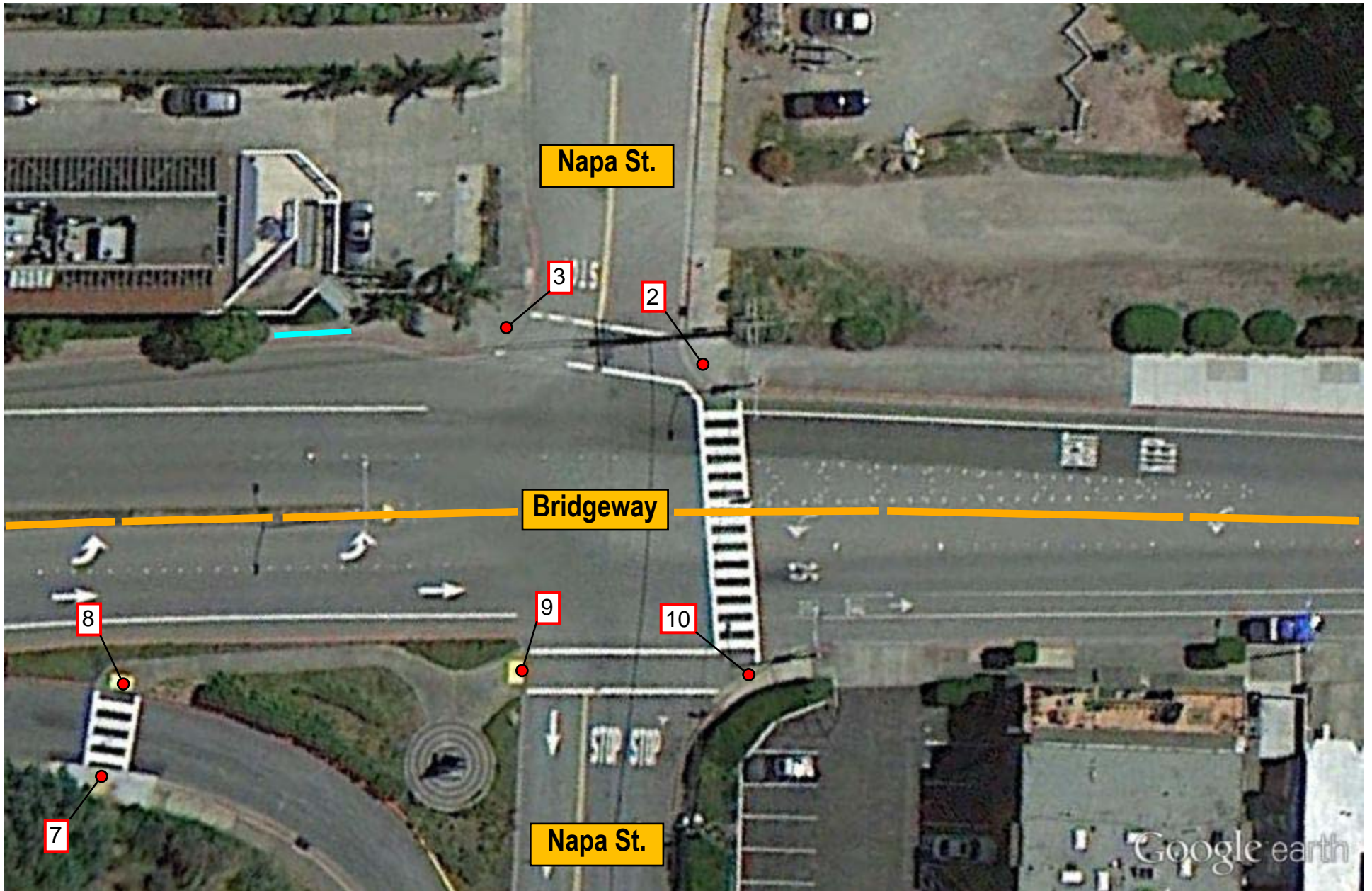

Google earth

Bridgeway Site Map #15  
Bridgeway  
Sausalito, CA





Google earth

Bridgeway Site Map #16  
Bridgeway  
Sausalito, CA



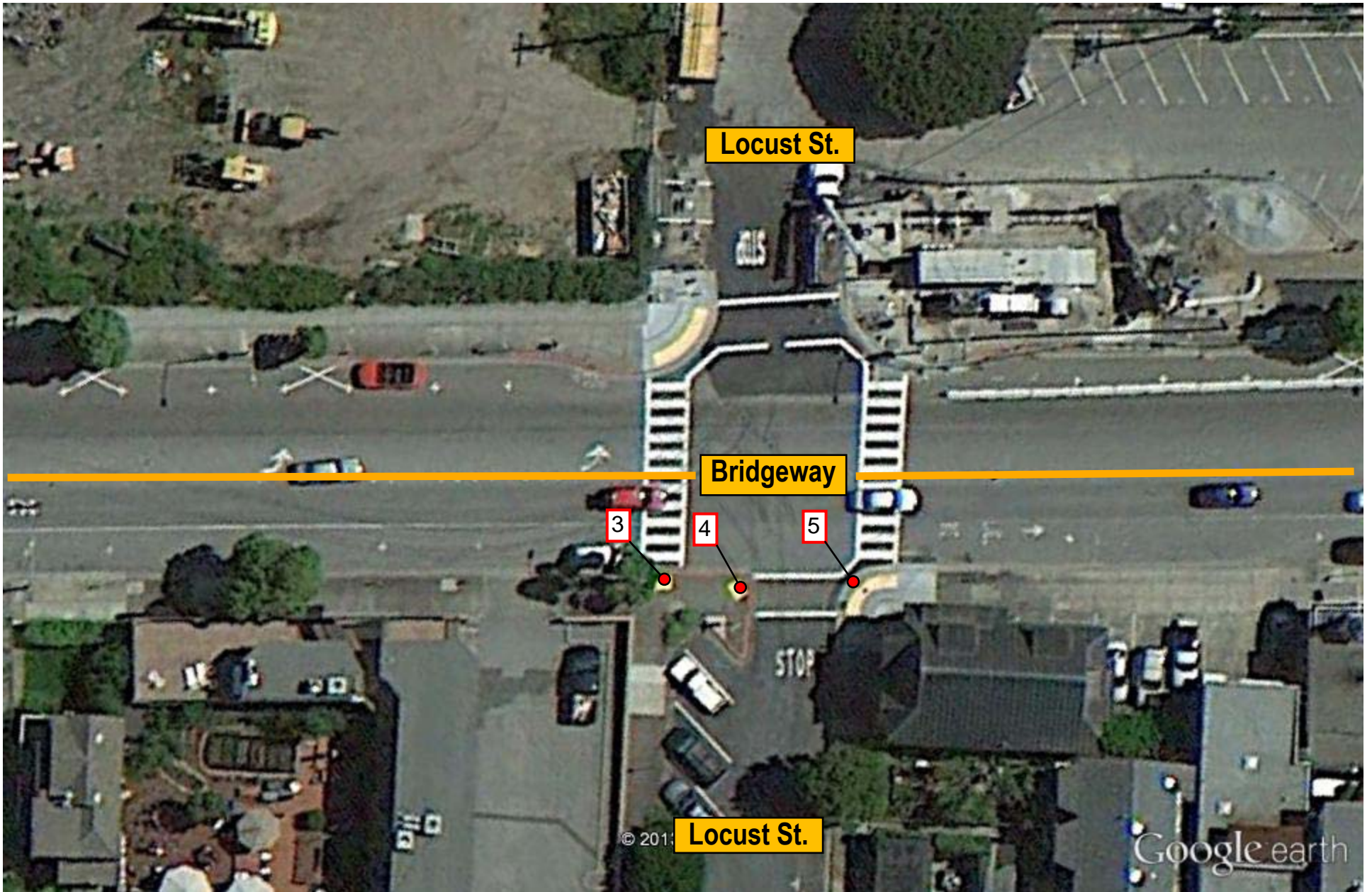

Bridgeway Site Map #18  
Bridgeway  
Sausalito, CA





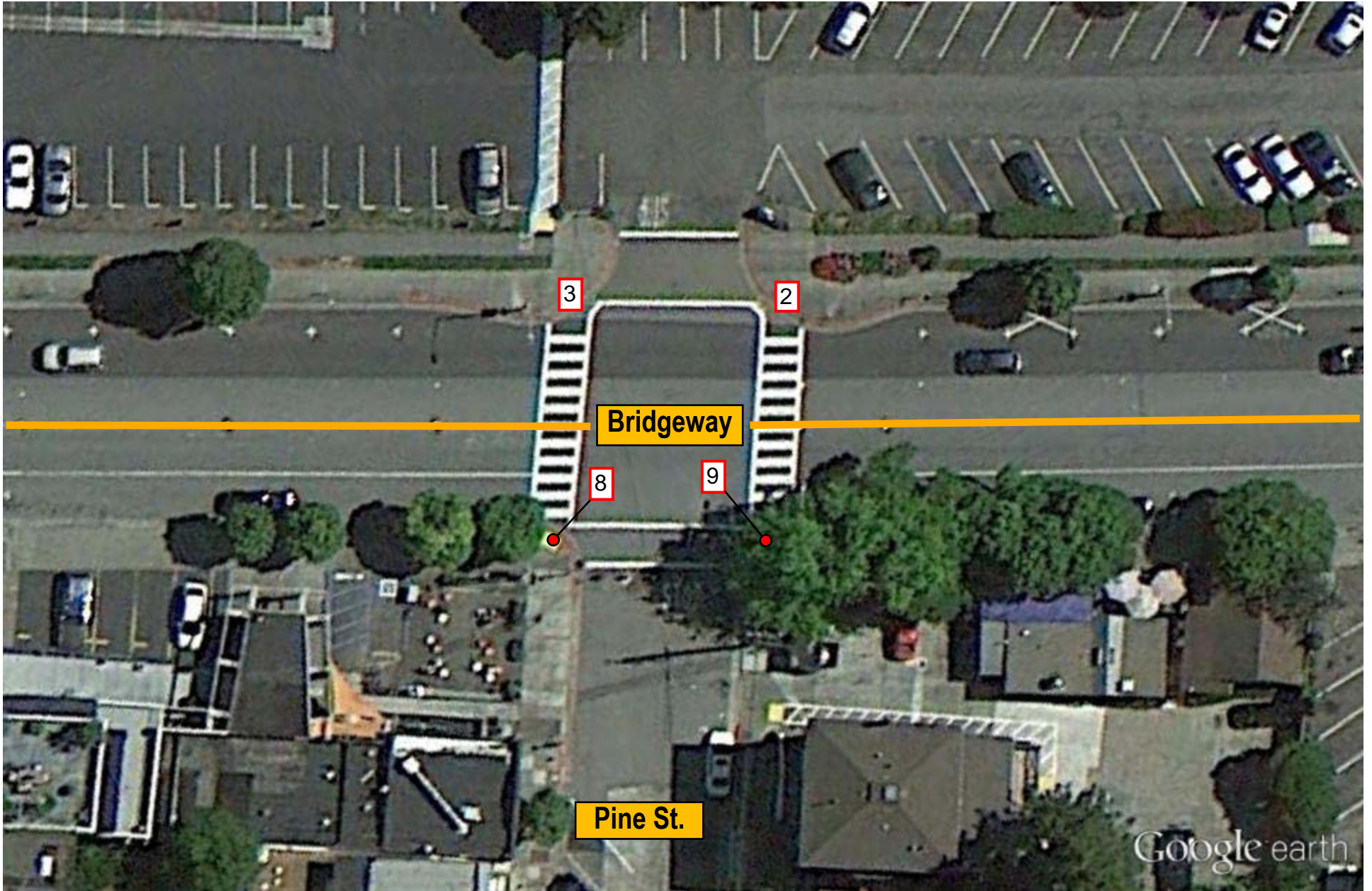

Google earth

Bridgeway Site Map #20  
Bridgeway  
Sausalito, CA

Google earth



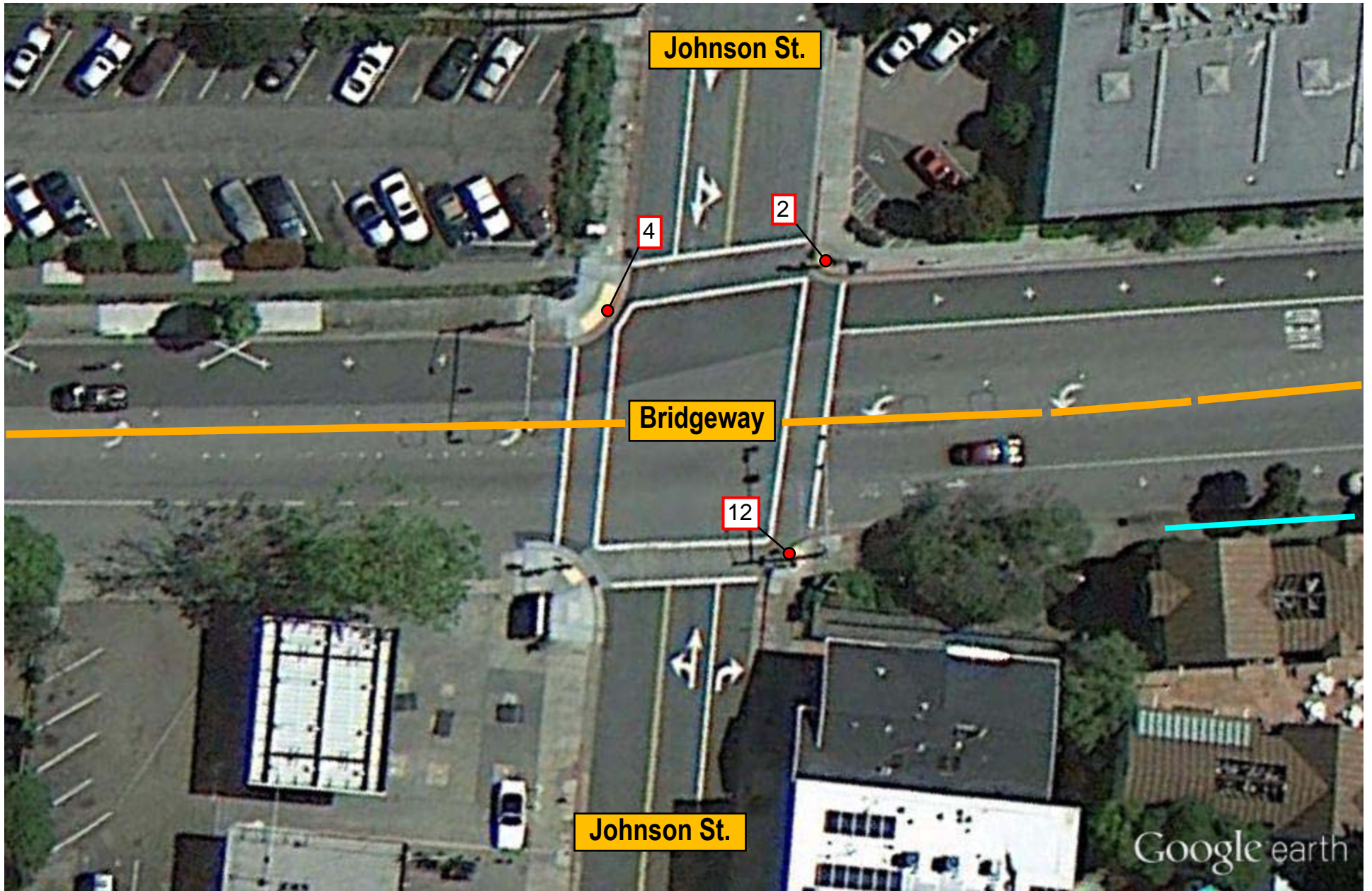

Google earth

Bridgeway Site Map #21  
Bridgeway  
Sausalito, CA



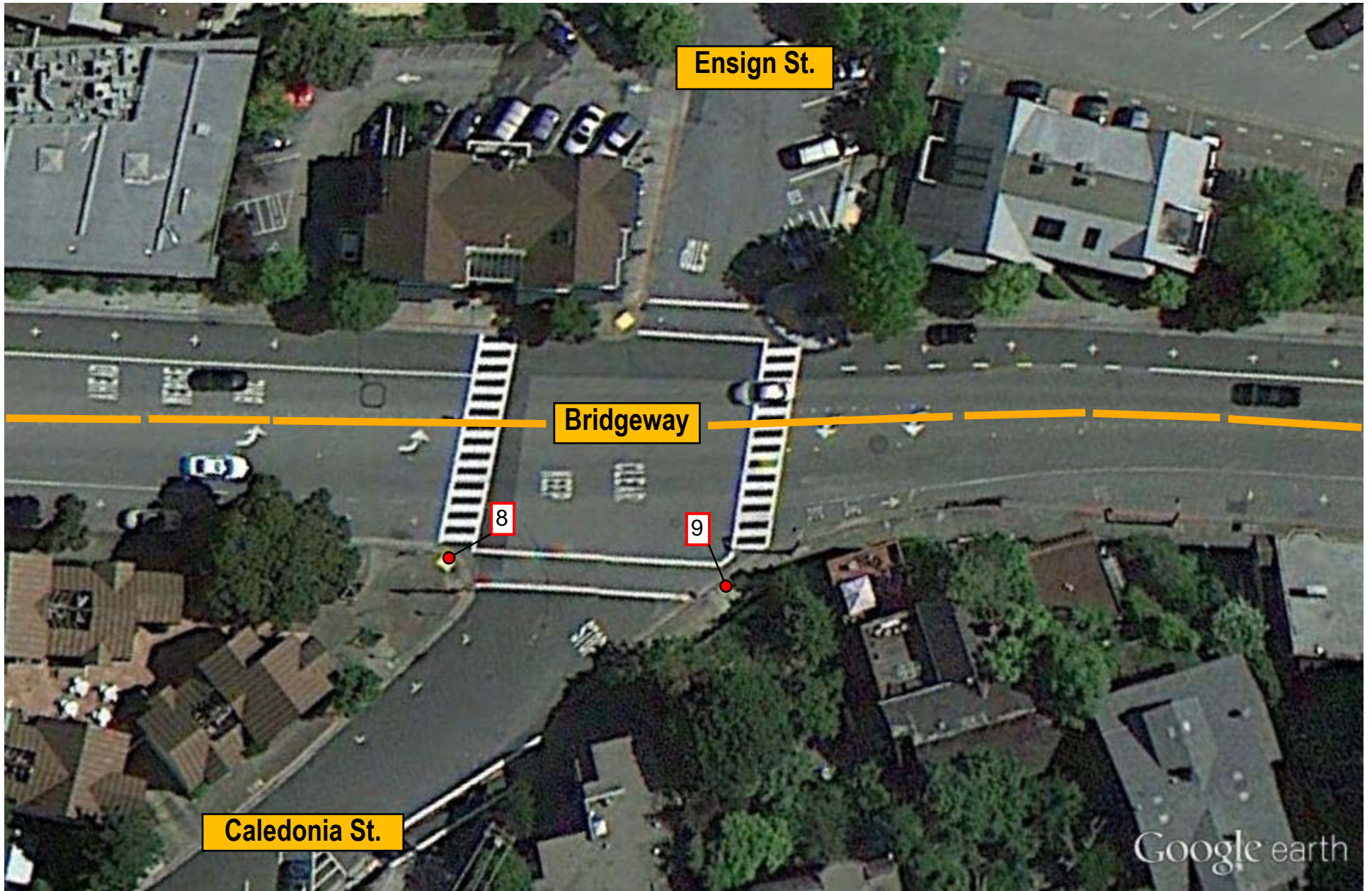

Google earth

Bridgeway Site Map #22  
Bridgeway  
Sausalito, CA



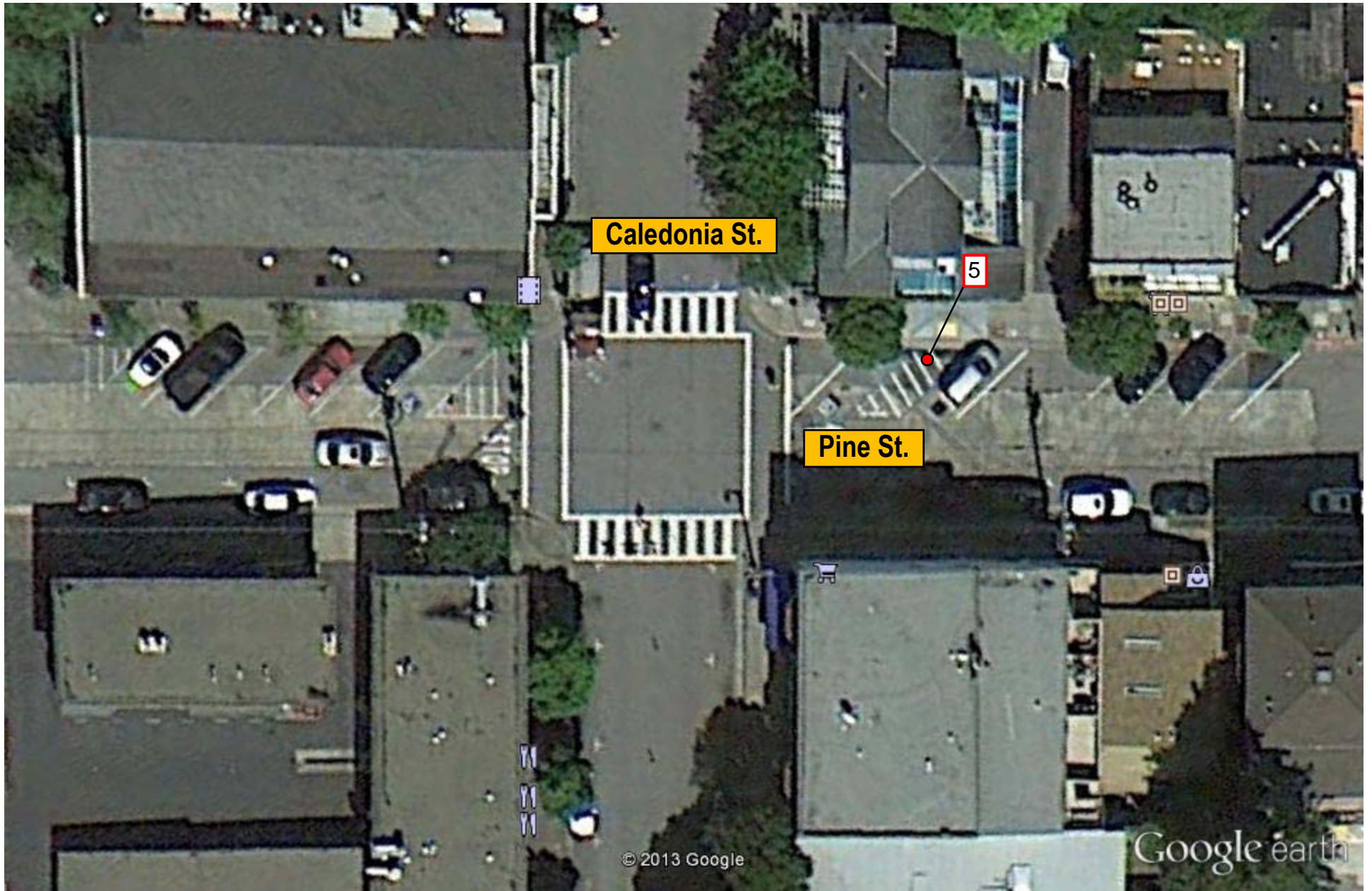

Google earth

Pine St. Blue Zones Site Map#1  
Pine St.  
Sausalito, CA



## BW 15-02



1. Remove <E> curb and gutter as shown.
2. Install <N> curb and gutter with 24" gutter pan with no lip at max 5% slope in running direction of crosswalk for entire width of ramp as shown.

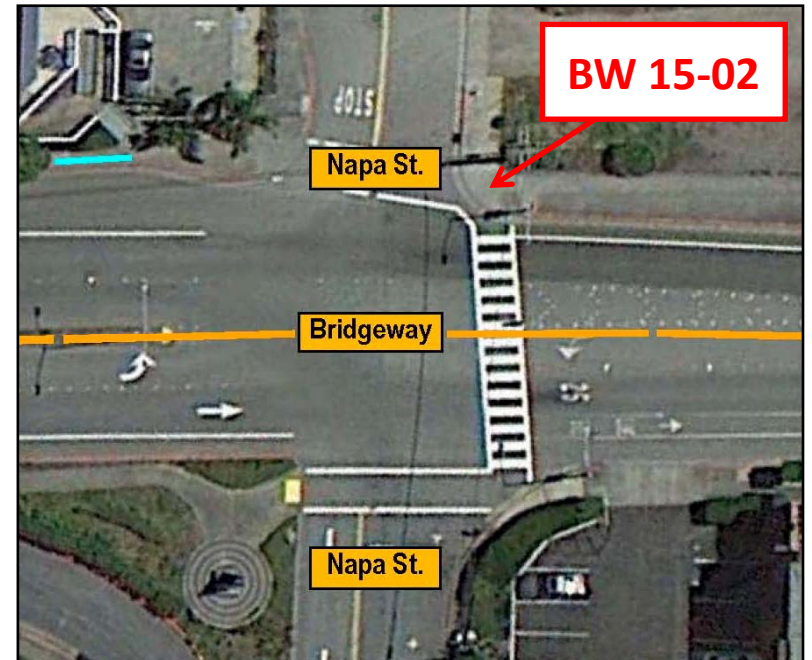

## BW 15-03



1. Remove <E> curb ramp and install <N> CASE C curb ramp wrapped around corner with detectable warning surface; See Caltrans RSP A88A dated March 21, 2014.
2. Install <N> ADA compliant landing at the top of the right ramp, which extends 4 ft. (including grooves) beyond the ramp for the full width of the ramp. Landing shall be 2% maximum slope in all directions.
3. <N> concrete at north side of curb ramp shall not encroach past south edge of <E> stairs.
4. Install <N> retaining curb at top of ramp in front of <E> sidewalk, as necessary. Taper curb height to match <N> grade at <N> landing.
5. Remove and reinstall <E> sign pole as necessary.
6. Install 24" gutter pan for entire width of new curb ramp, including upper landing and transition areas. Gutter shall have no lip and max 5% slope in running direction of crosswalk for entire width of lower landing.

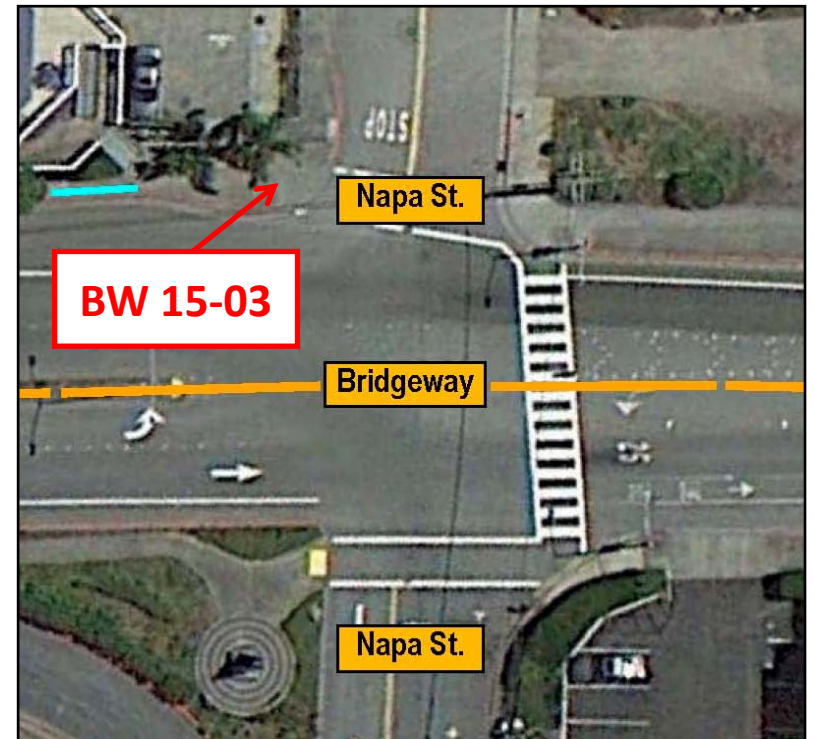

## BW 15-07



1. Remove <E> curb and gutter as shown.
2. Install <N> curb and gutter with 24" gutter pan for entire lip of curb ramp. No lip and max 5% slope in running direction of crosswalk for entire width of lower landing

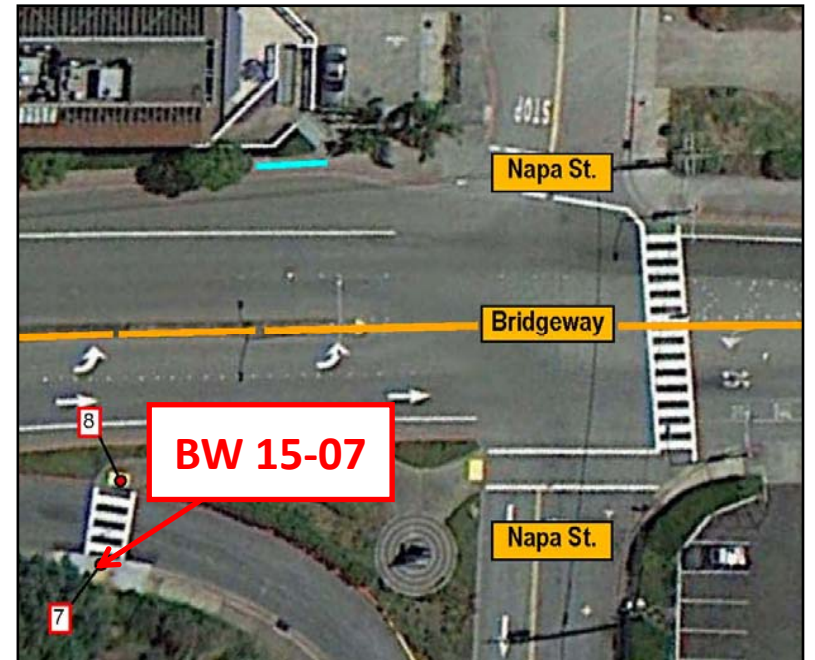

# BW 15-08

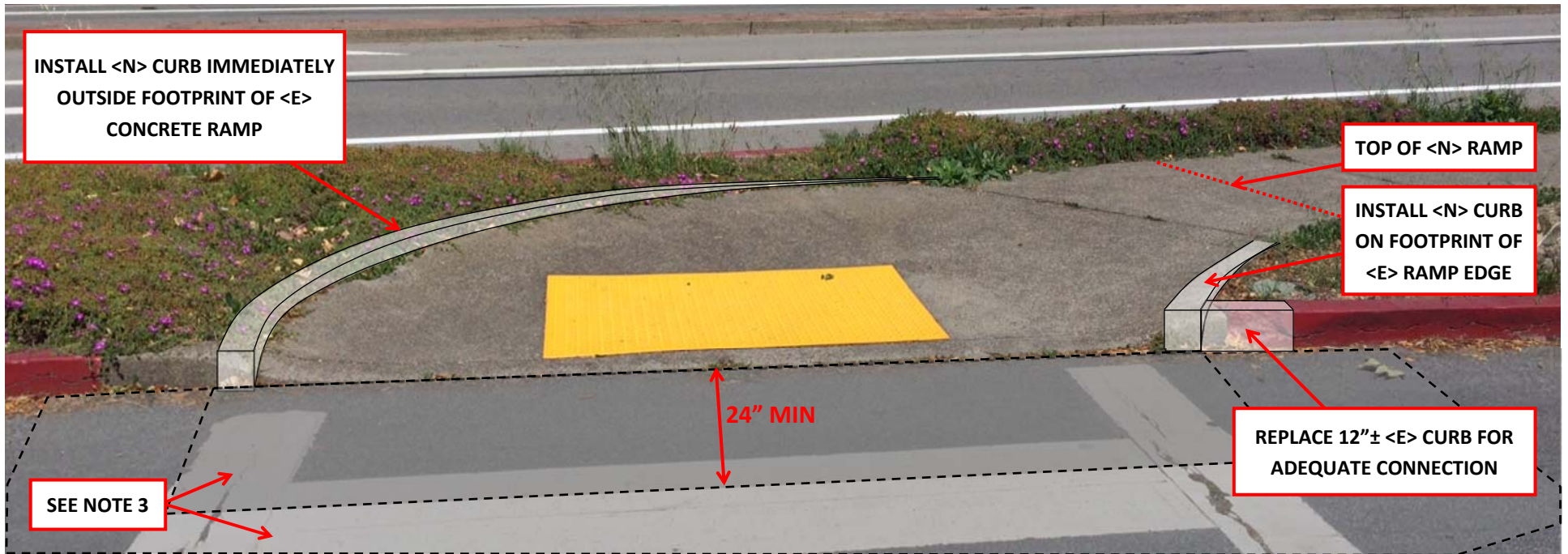

1. Remove <E> curb ramp and install <N> CASE F curb ramp with detectable warning surface; See Caltrans RSP A88A dated March 21, 2014.
2. Install retaining curbs as shown. Taper curb height to match <N> grade.
3. Remove and replace AC with max 5% slope for entire width of ramp for 24" in running direction of crosswalk. Remove and replace up to an additional 24" of AC beyond to smoothly conform with <E> AC.

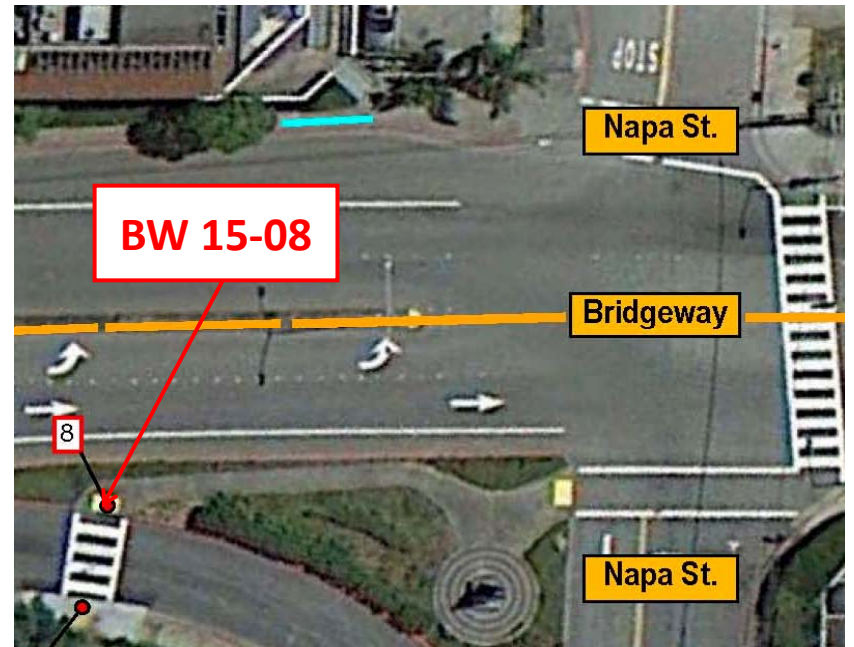



# BW 15-09

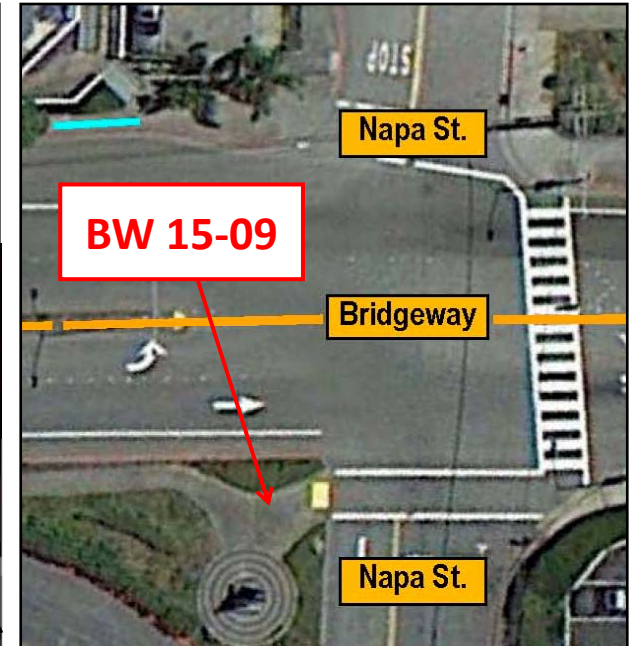
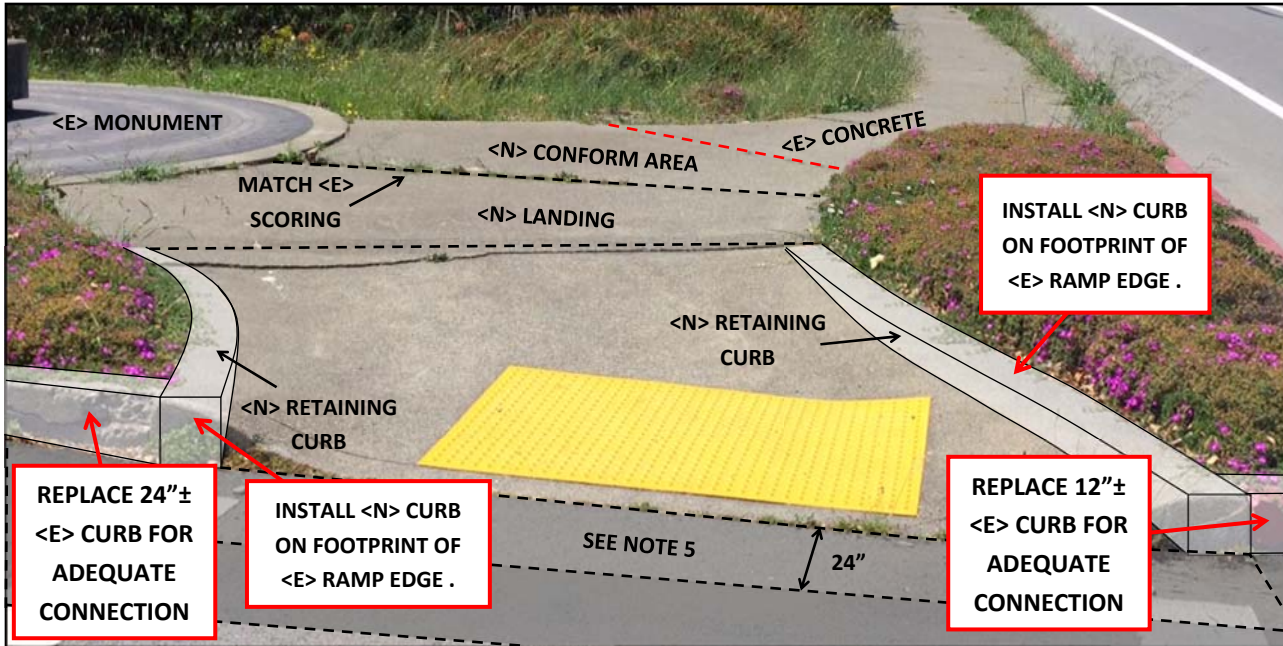

1. Remove <E> curb ramp and install <N> CASE F curb ramp with detectable warning surface; See Caltrans RSP A88A dated March 21, 2014.
2. No lip at transition from <N> concrete to <E> monument.
3. Max 2% cross slope at conform area between <N> landing and <E> sidewalk.
4. Install retaining curbs as shown. Taper curb height to match <N> grade at <N> landing.
5. Remove and replace AC with max 5% slope for entire width of ramp for 24" in running direction of crosswalk. Remove and replace up to an additional 24" of AC beyond to smoothly conform with <E> AC.
6. Remove <E> survey benchmark and provide to City for future resetting.

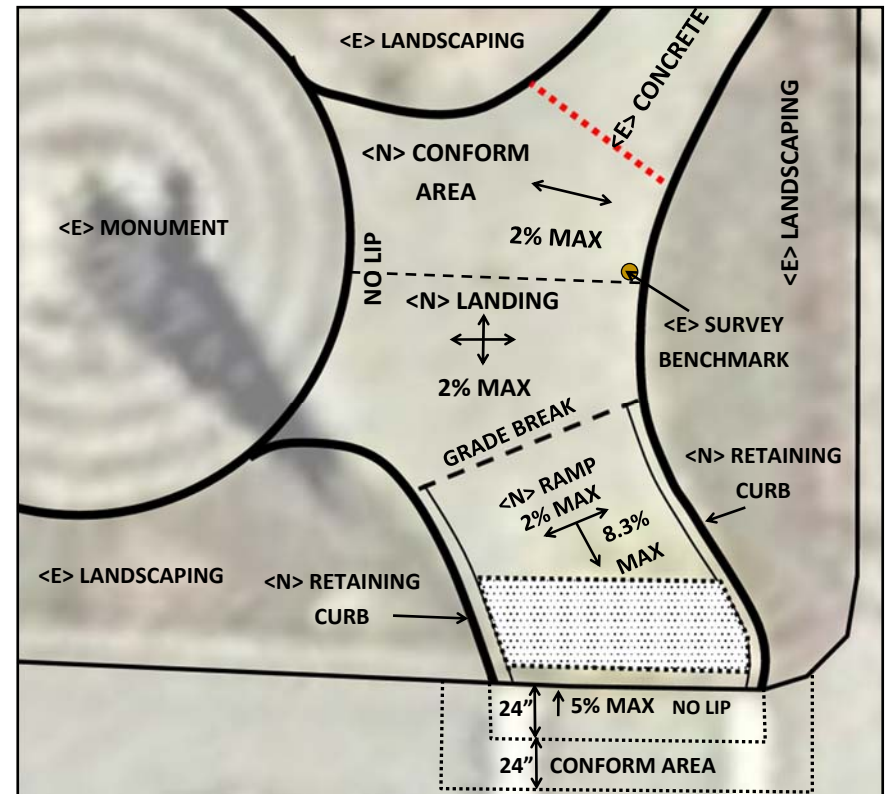

## BW 15-10

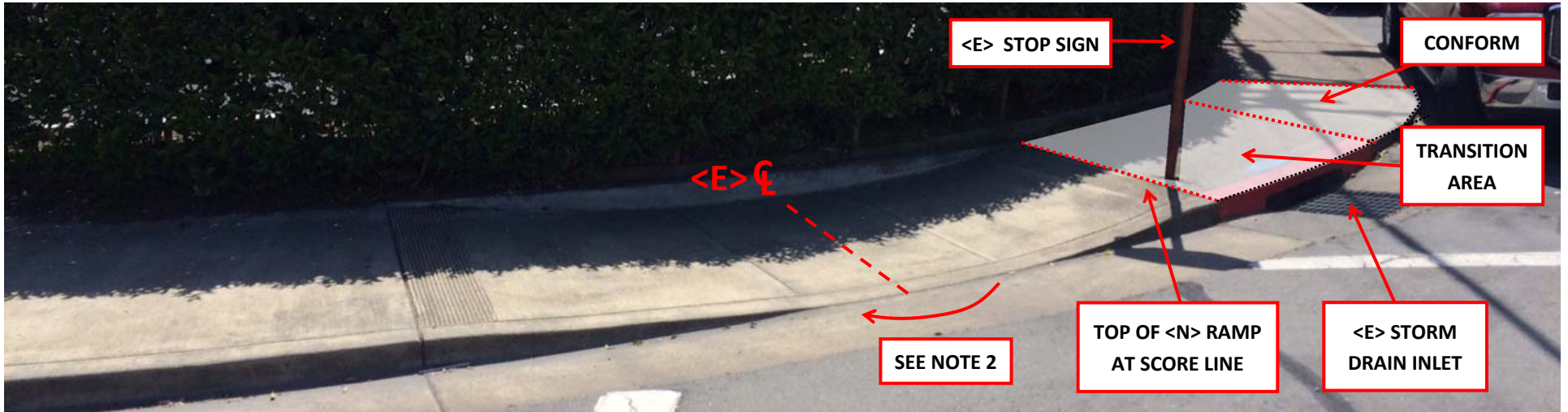

1. Remove and replace <E> curb ramp and install <N> CASE C curb ramp with detectable warning surface; See Caltrans RSP A88A dated March 21, 2014.
2. Rotate centerline of lower landing of <N> curb ramp as necessary to achieve maximum slope restrictions and avoid conflict between <N> ramp and <E> storm drain inlet.
3. Install <N> transition area between existing score lines, as shown, with maximum 2% cross slope.
4. Install <N> ADA compliant landing at the top of the left ramp, which extends 4 ft. (including grooves) beyond the ramp for the full width of the ramp. Landing shall be 2% maximum slope in all directions.
5. Protect <E> landscape at back of sidewalk with <N> 4" retaining curb as necessary. Taper curb height to match <E> grade.
6. Maintain <E> sidewalk width.
7. Remove and reinstall <E> stop sign as necessary. If removed, provide temporary stop sign until reinstalled.
8. Install 24" gutter pan for entire width of new curb ramp, including upper landing and transition areas. Gutter shall have no lip and max 5% slope in running direction of crosswalk for entire width of lower landing.

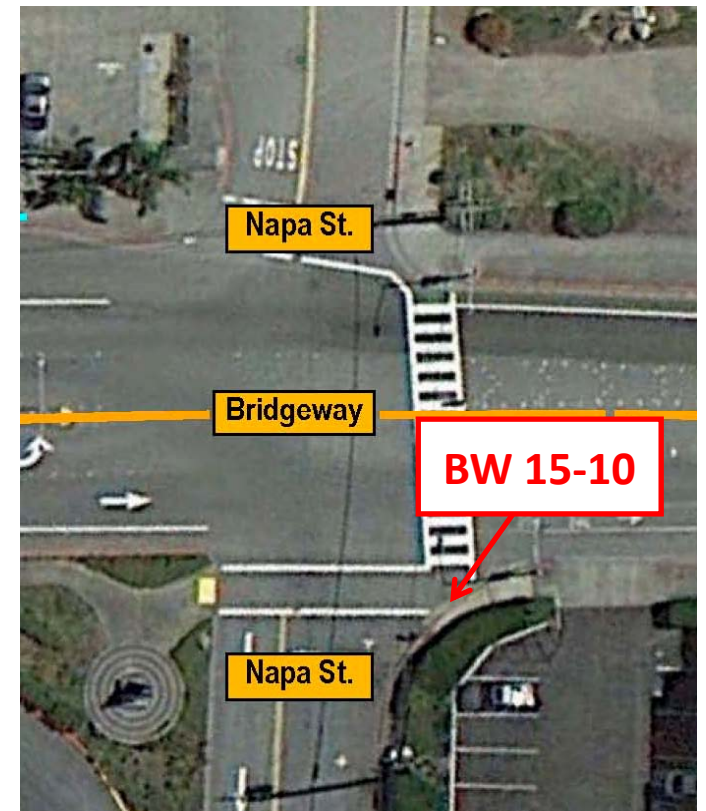

## BW 16-03



1. Remove <E> curb ramp and install <N> MODIFIED CASE C curb ramp with CASE F curb ramp retaining curbs and detectable warning surface; See Caltrans RSP A88A dated March 21, 2014.
2. Lower landing to extend from face of curb to back of walk.
3. <N> ramp widths to match <E> sidewalk width.
4. Install <N> ADA compliant landing at the top of the left ramp, which extends 4 ft. (including grooves) beyond the ramp for the full width of the ramp. Landing shall be 2% maximum slope in all directions.
5. Install <N> retaining curb at back of lower landing and ramps as shown. Taper curb height to match <N> grade.
6. Install <N> retaining curbs around <E> landscaping as shown. Taper curb height to match <N> grade.
7. Install 24" gutter pan with max 5% slope in running direction of crosswalk for entire width of lower landing.

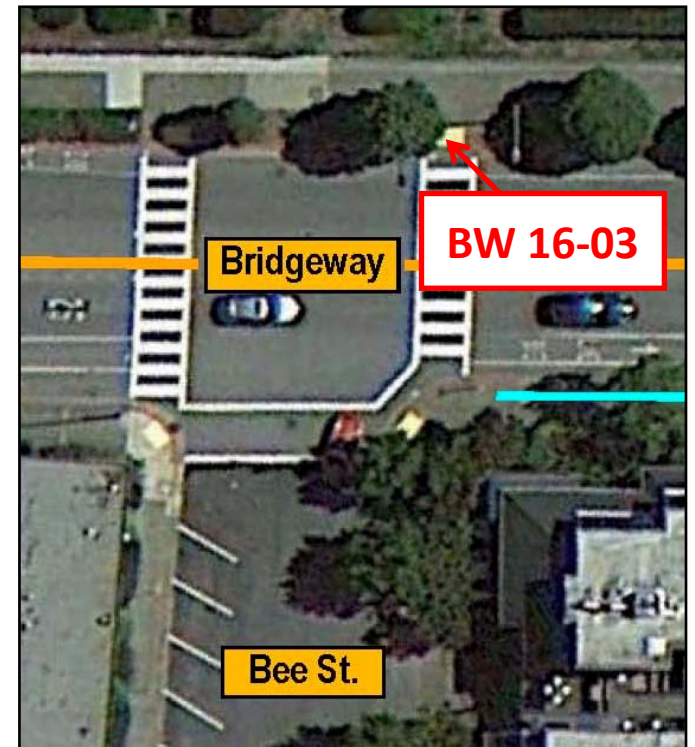

## BW 18-03



1. Remove <E> curb ramp and install <N> CASE A curb ramp with detectable warning surface; See Caltrans RSP A88A dated March 21, 2014.
2. Remove <E> storm drain turning structure frame and lid. Replace with <N> South Bay Foundry SBF 1900 24" manhole frame and cover, or approved equal. Modify <E> storm drain turning structure to accept <N> manhole frame and lid. Lid shall be labeled "Storm Drain".
3. Remove and reset <E> storm drain manhole cover and frame.
4. Install 24" gutter pan for entire width of new curb ramp, including flares and any transition areas. Gutter shall have no lip and max 5% slope in running direction of crosswalk for entire width of ramp.

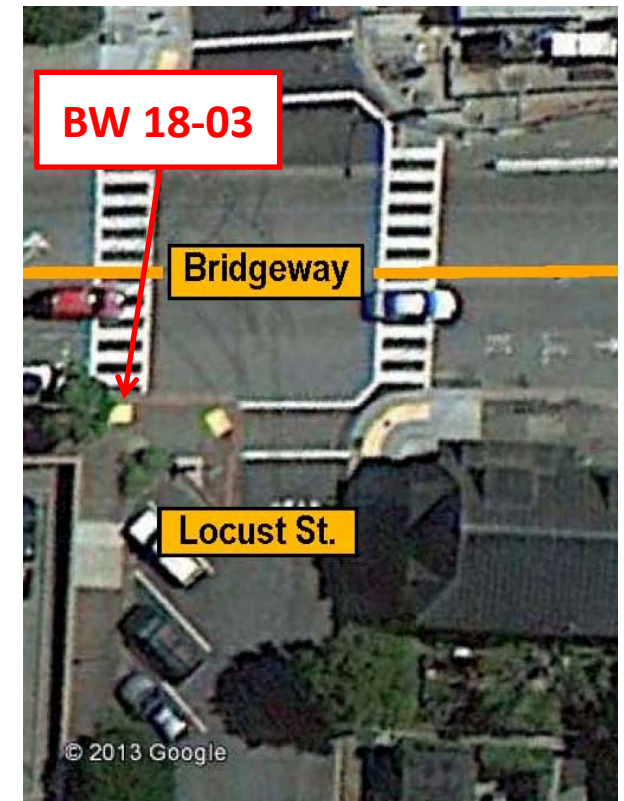

## BW 18-04

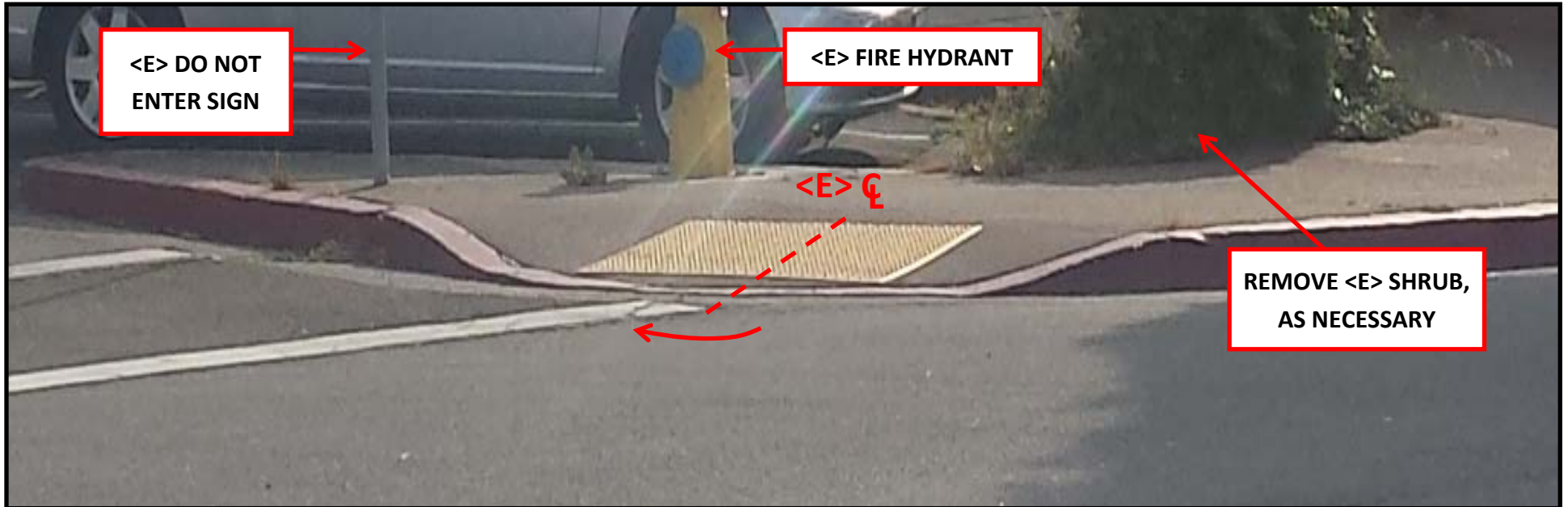

1. Remove <E> curb ramp and install <N> CASE A curb ramp with detectable warning surface; See Caltrans RSP A88A dated March 21, 2014.
2. Remove <E> shrub and replace with <N> sidewalk if necessary for <N> landing.
3. Rotate centerline of <N> curb ramp as necessary to align more closely with <E> crosswalk.
4. Install 24" gutter pan for entire width of new curb ramp, including flares and any transition areas. Gutter shall have no lip and max 5% slope in running direction of crosswalk for entire width of ramp.
5. Remove and reinstall <E> Do Not Enter Sign as necessary. If removed, provide temporary Do Not Enter Sign until reinstalled.

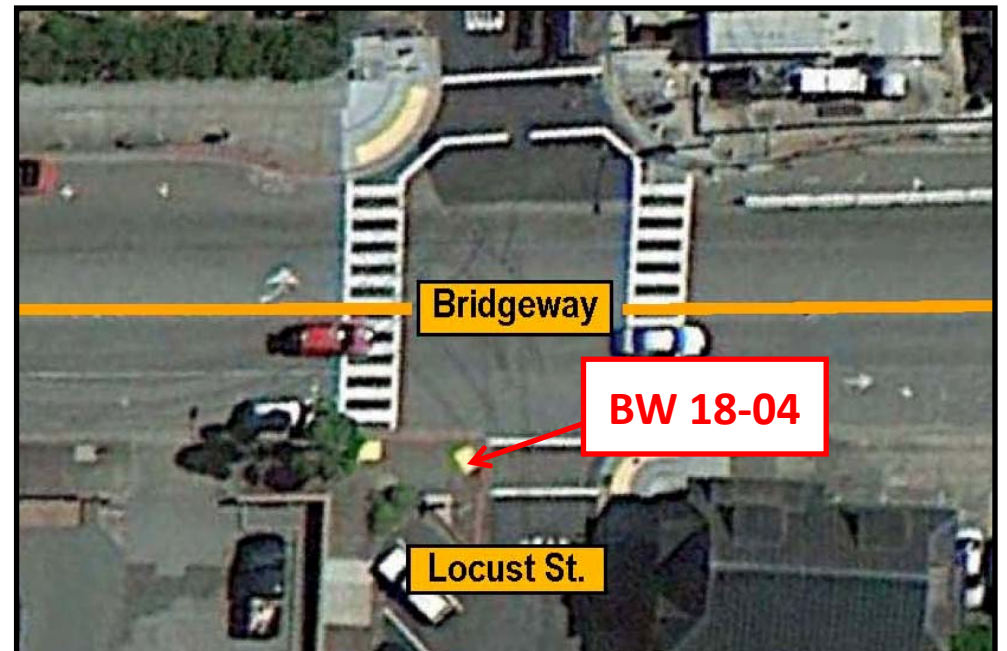

## BW 18-05



**<E> STORM DRAIN  
FRAME AND GRATE**

1. Remove <E> storm drain frame and grate. Replace with <N> ADA compliant frame and grate, Marin County Uniform Construction Standard Type C. Modify <E> storm drain box as necessary to accept <N> ADA compliant frame and grate. Install storm drain grate so that 1/2" grate openings are perpendicular to path of pedestrian travel.

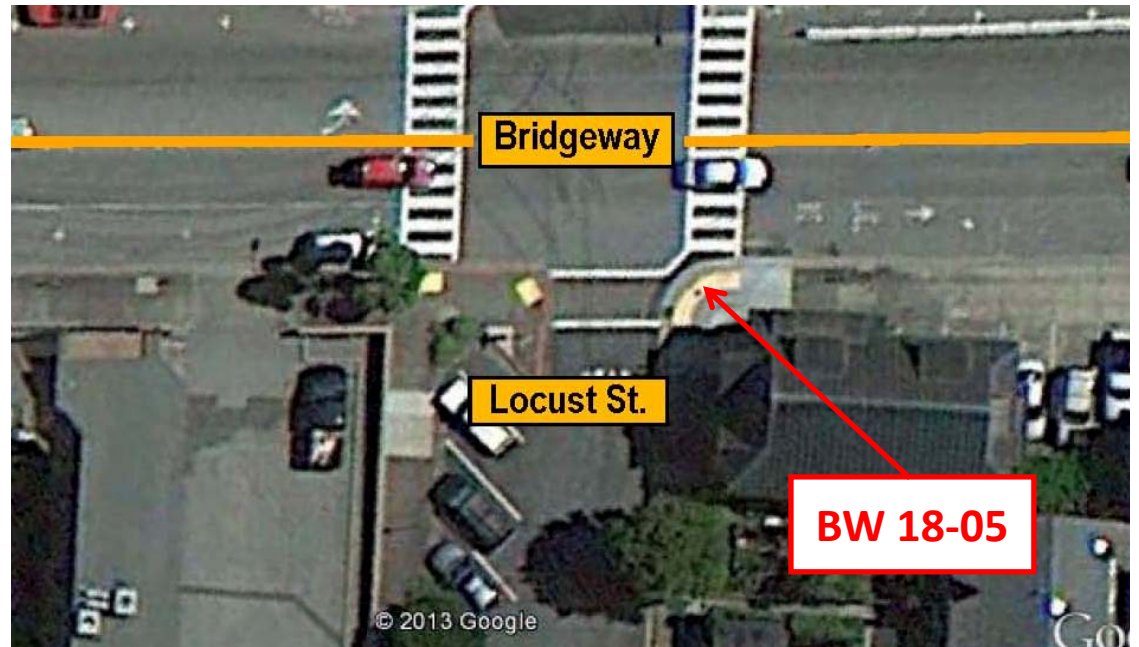

**BW 18-05**

## BW 20-02



1. Remove <E> curb and gutter as shown.
2. Install <N> curb and gutter with 24" gutter pan with no lip and max 5% slope in running direction of crosswalk for entire width of ramp as shown.

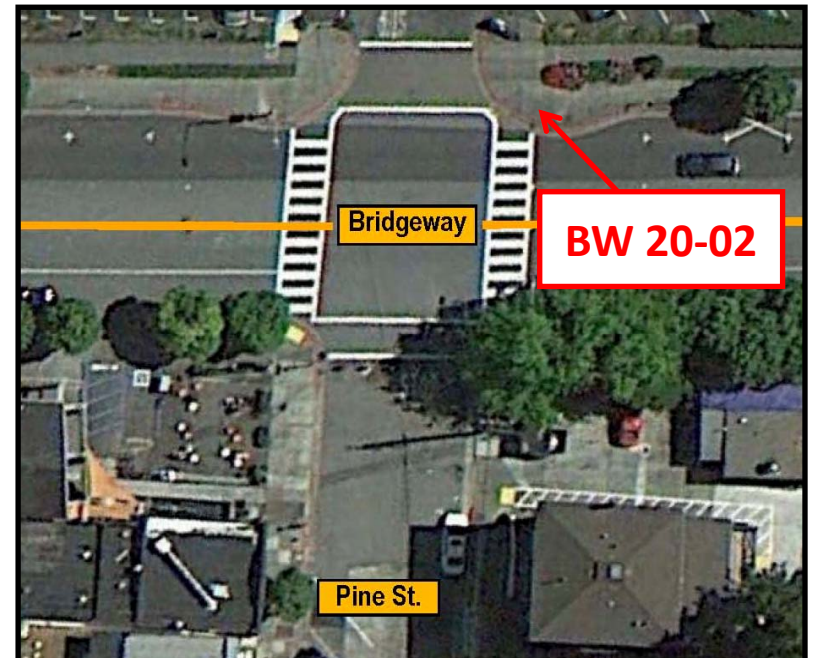

## BW 20-03



1. Remove <E> curb and gutter as shown.
2. Install <N> curb and gutter with 24" gutter pan with no lip and max 5% slope in running direction of crosswalk for entire width of ramp as shown.

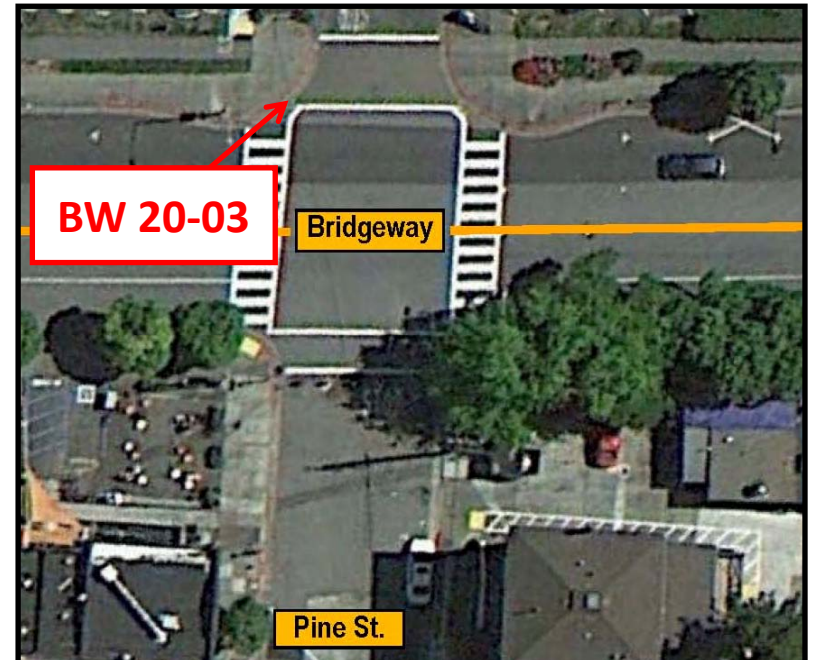



## BW 20-08



1. Remove <E> curb ramp and install <N> MODIFIED CASE C curb ramp wrapped around corner with detectable warning surface ; See Caltrans RSP A88A dated March 21, 2014.
2. Install <N> ADA compliant landing at the top of each ramp, which extends 4 ft. (including grooves) beyond the ramp for the full width of the ramp. Landing shall be 2% maximum slope in all directions.
3. Install <N> curb to retain <E> surface behind <N> ramps. Taper curb height to match <N> grade.
4. Protect <E> tree with curb on 2 sides. Taper curb height to match <E> sidewalk and <N> ramp grade.
5. Install 24" gutter pan for entire width of new curb ramp, including upper landings and transition areas. Gutter shall have no lip and max 5% slope in running direction of crosswalk for entire width of lower landing.
6. Remove <E> storm drain frame and grate. Replace with <N> ADA compliant frame and grate, Marin County Uniform Construction Standard Type C. Modify <E> storm drain box as necessary to accept <N> ADA compliant frame and grate. Install storm drain grate so that 1/2" grate openings are perpendicular to path of pedestrian travel.
7. Remove and reinstall <E> sign pole as necessary.

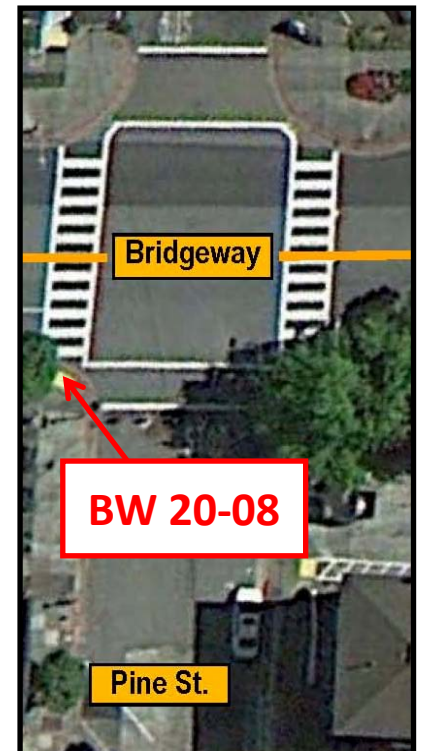



## BW 21-02

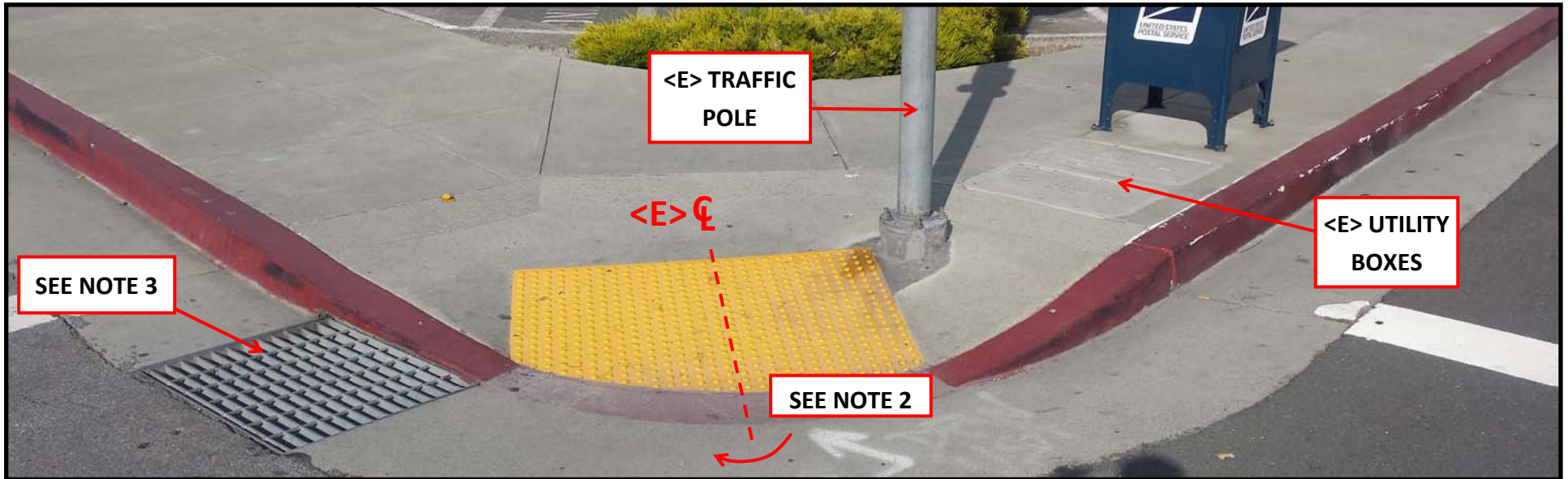

1. Remove and replace <E> curb ramp and install <N> CASE A curb ramp with detectable warning surface; See Caltrans RSP A88A dated March 21, 2014.
2. Rotate centerline of <N> curb ramp as necessary to achieve max 10% left and right flares, without relocation of <E> utility vaults and mailbox.
3. Remove <E> storm drain frame and grate. Replace with <N> ADA compliant frame and grate, Marin County Uniform Construction Standard Type C. Modify <E> storm drain box as necessary to accept <N> ADA compliant frame and grate. Install storm drain grate so that 1/2" grate openings are perpendicular to path of pedestrian travel.
4. Grout under <E> traffic pole base if exposed.
5. Install 24" gutter pan for entire width of new curb ramp, including flares and any transition areas. Gutter shall have no lip and max 5% slope in running direction of crosswalk for entire width of ramp.

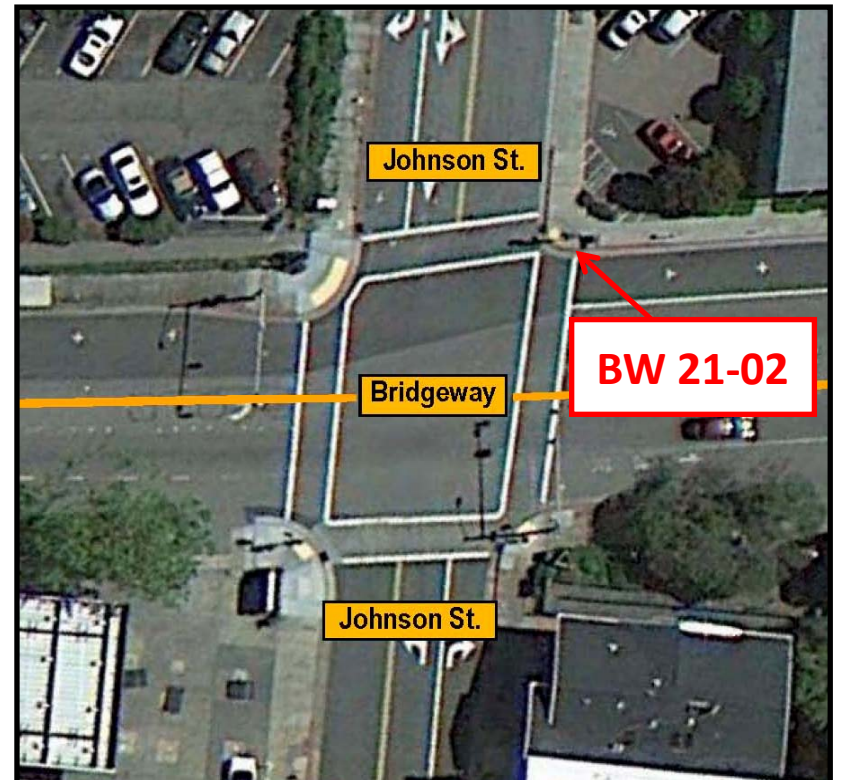

## BW 21-04

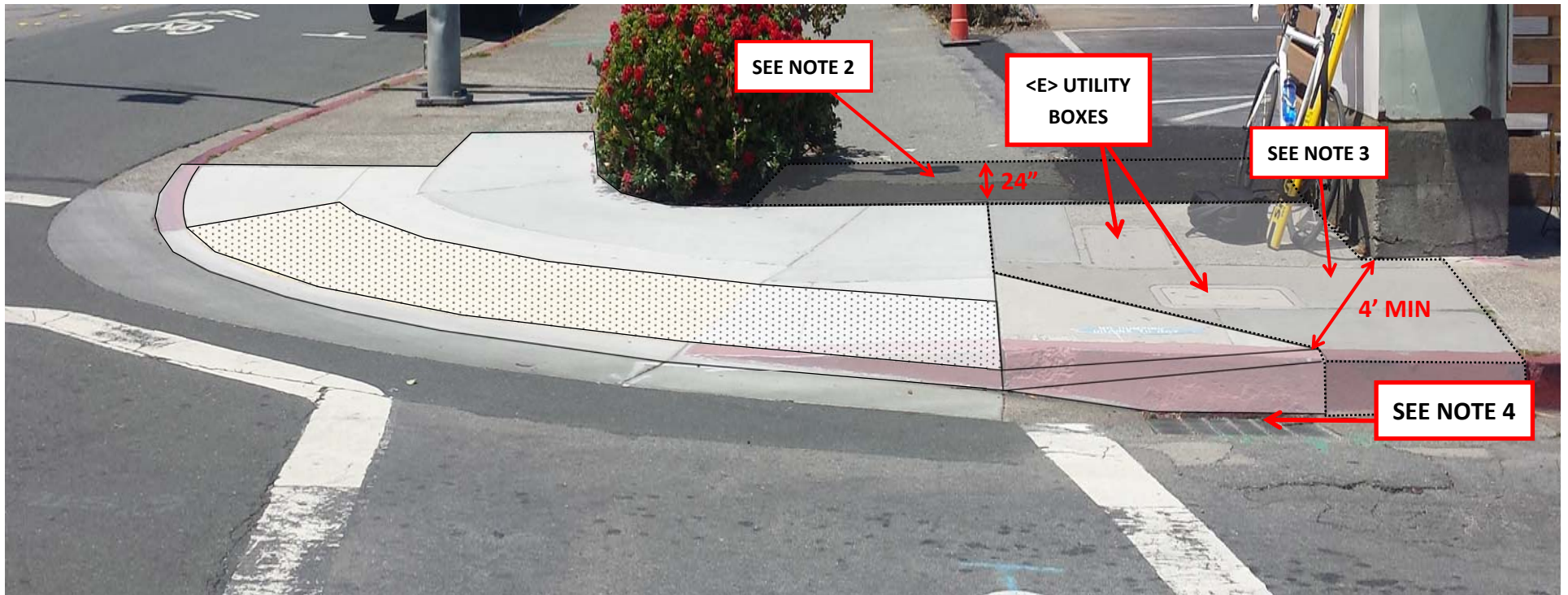

1. Remove and replace <E> curb ramp and install <N> CASE A curb ramp wrapped around corner with detectable warning surface; See Caltrans RSP A88A dated March 21, 2014.
2. Remove and replace up to 24" of AC at bike path to conform <N> landing and path of travel with <E> AC.
3. Maintain 4' clear path of travel from sidewalk to landing. Maximum 2% slope in all directions at <N> path of travel.
4. Remove <E> storm drain frame and grate. Replace with <N> ADA compliant frame and grate, Marin County Uniform Construction Standard Type C. Modify <E> storm drain box as necessary to accept <N> ADA compliant frame and grate. Install storm drain grate so that 1/2" grate openings are perpendicular to path of pedestrian travel.
5. Install 24" gutter pan for entire width of new curb ramp, including flares and transition areas. Gutter shall have no lip and max 5% slope in running direction of crosswalk for entire width of ramp.

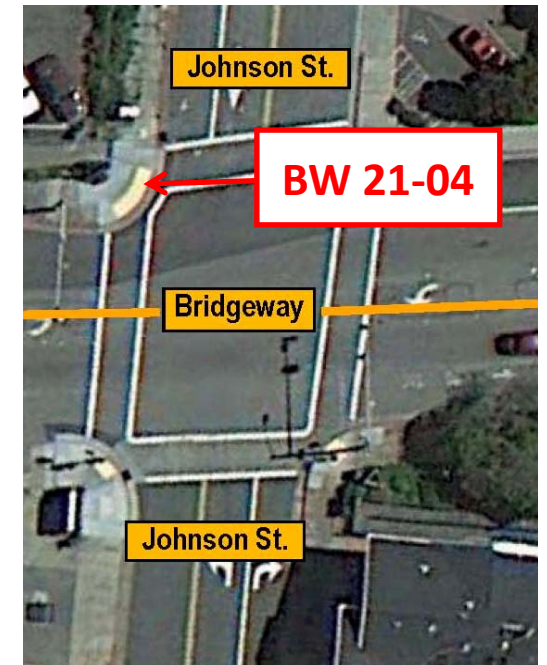

## BW 21-12

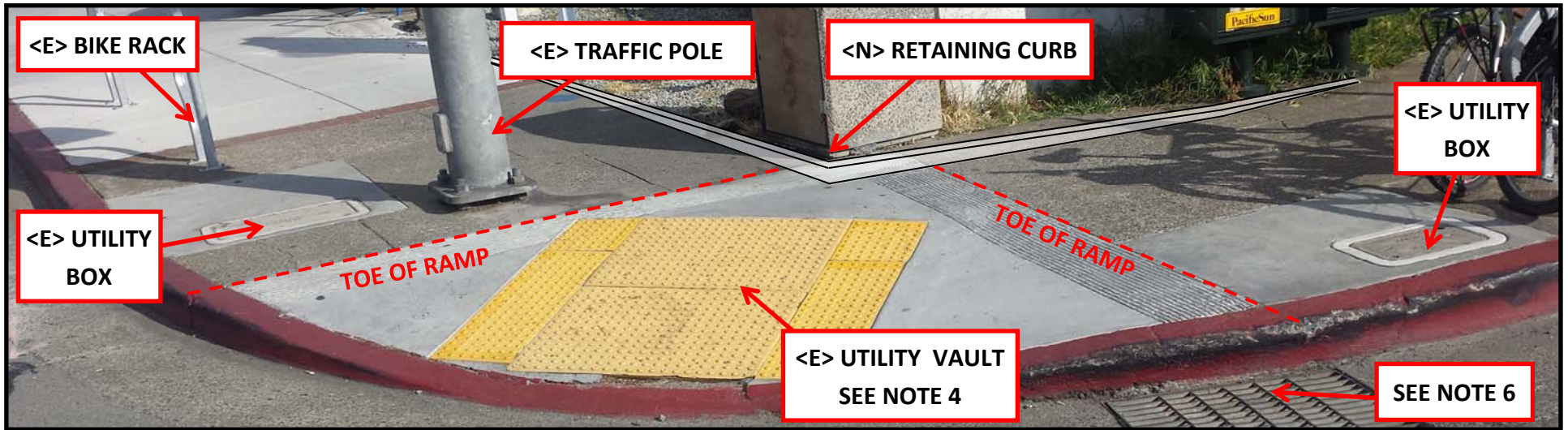

1. Remove <E> curb ramp and install <N> CASE C curb ramp wrapped around corner with detectable warning surface; See Caltrans RSP A88A dated March 21, 2014.
2. Install <N> retaining curb at back of ramps to protect <E> landscaping. Taper curb height to match <N> grade.
3. Grout under <E> traffic pole base if exposed.
4. Install **Armor-Tile ADA-S Surface Applied Detectable/Tactile Warning Surfaces**—Yellow Color 33538 of Federal Standard 595 (TYP). Install panels entire width of <N> ramp from back of <E> vault to immediately behind back of curb (TYP). Use adhesive to attach panels to vault lid. Install panels covering vault flush with adjacent panels. Apply surface to maintain vault access.
5. Install 24" gutter pan for entire width of new curb ramp. Gutter shall have no lip and max 5% slope in running direction of crosswalk for entire width of lower landing.
6. Remove <E> storm drain frame and grate. Replace with <N> ADA compliant frame and grate, Marin County Uniform Construction Standard Type C. Modify <E> storm drain box as necessary to accept <N> ADA compliant frame and grate. Install storm drain grate so that 1/2" grate openings are perpendicular to path of pedestrian travel.
7. Remove and replace approximately 20 SF of <E> concrete crosswalk as directed by City to remove 1" vertical slope displacement.
8. Remove and reinstall <E> bike rack as necessary.

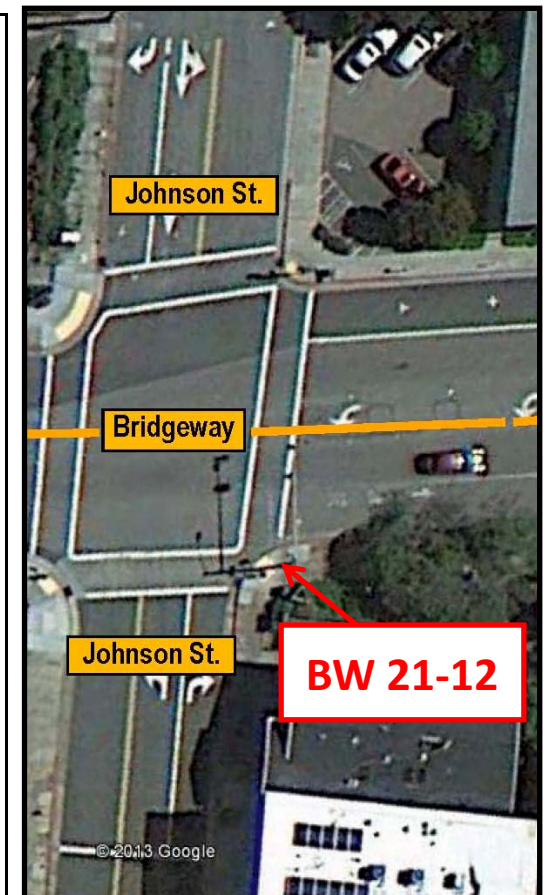

## BW 22-08

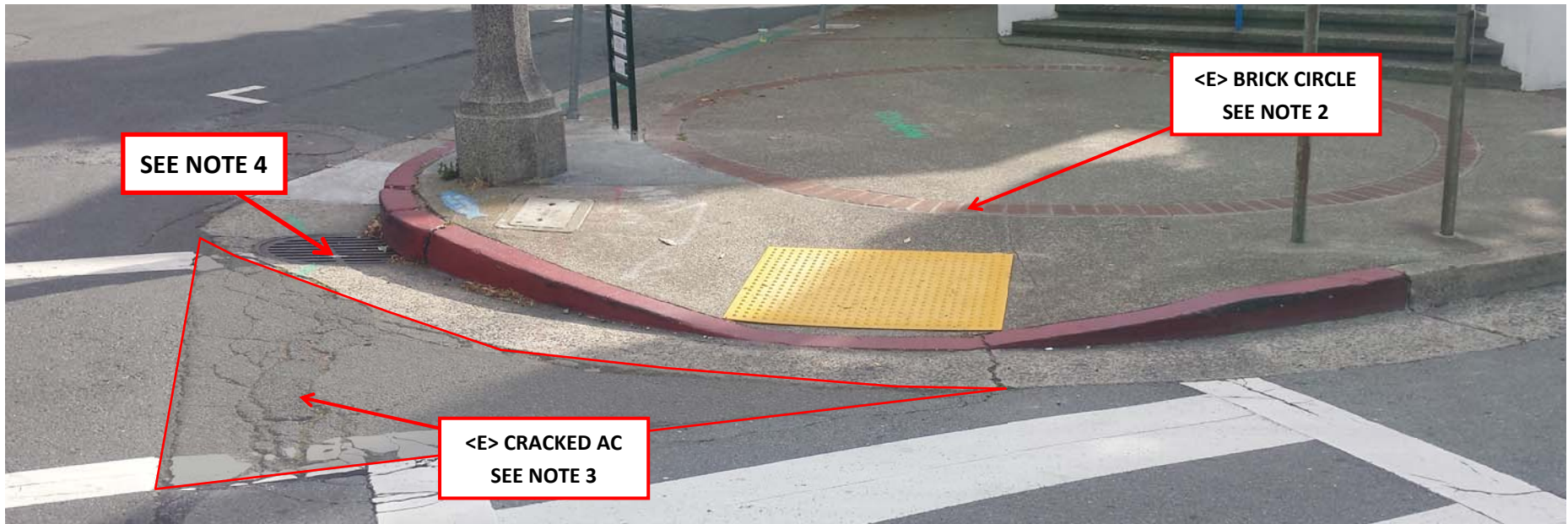

1. Remove <E> curb ramp and install <N> CASE A curb ramp with detectable warning surface; See Caltrans RSP A88A dated March 21, 2014.
2. If any bricks are removed for the construction of the <N> curb ramp, replace to match <E> brick circle. (See Specification Section 7-11.01)
3. Remove and replace approximately 50 SF of cracked AC crosswalk as directed by City.
4. Remove <E> storm drain frame and grate. Replace with <N> ADA compliant frame and grate, Marin County Uniform Construction Standard Type C. Modify <E> storm drain box as necessary to accept <N> ADA compliant frame and grate. Install storm drain grate so that 1/2" grate openings are perpendicular to path of pedestrian travel.
5. Install 24" gutter pan for entire width of new curb ramp, flares and any transition areas. Gutter shall have no lip and max 5% slope in running direction of crosswalk for entire width of ramp

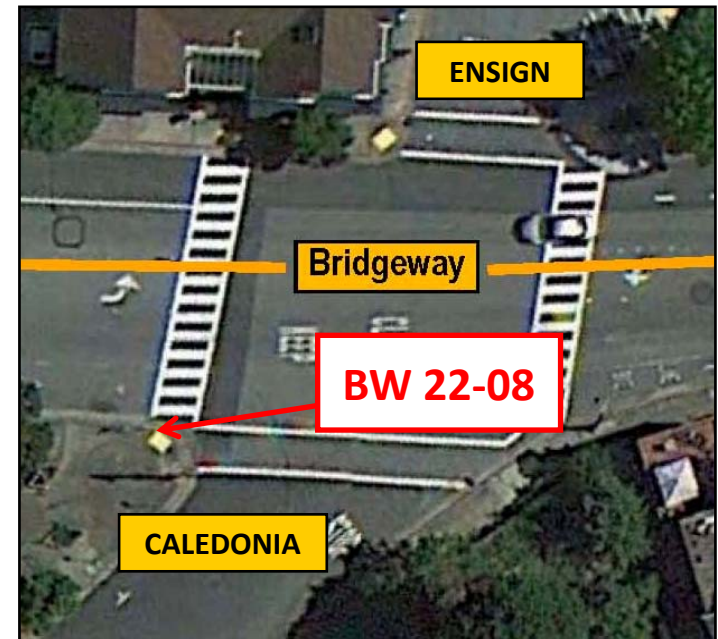

## BW 22-09



1. Remove <E> curb ramp and install <N> CASE C curb ramp wrapped around corner with detectable warning surface; See Caltrans RSP A88A dated March 21, 2014.
2. Maintain <E> sidewalk width.
3. Install <N> ADA compliant landing at the top of the right ramp, which extends 4 ft. (including grooves) beyond the ramp for the full width of the ramp. Landing shall be 2% maximum slope in all directions.
4. Maintain 12" clearance from <E> survey benchmark to edge of <N> concrete conform at right side of curb ramp.
5. Install <N> retaining curb at back of ramp. Taper curb height to match <N> grade.
6. Maintain <E> sidewalk width.
7. Remove and reinstall <E> sign pole as necessary.
8. Install 24" gutter pan for entire width of new curb ramp, including upper landing and transition areas. Gutter shall have no lip and max 5% slope in running direction of crosswalk for entire width of lower landing.
9. Remove and reinstall <E> Stop Sign as necessary. If removed, provide temporary Stop Sign until reinstalled.

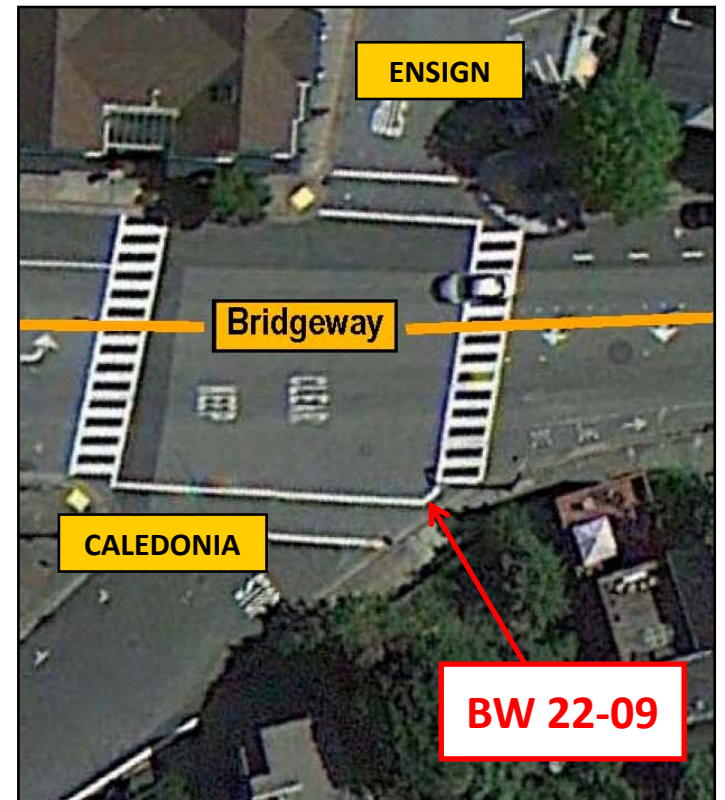

## PSP-05

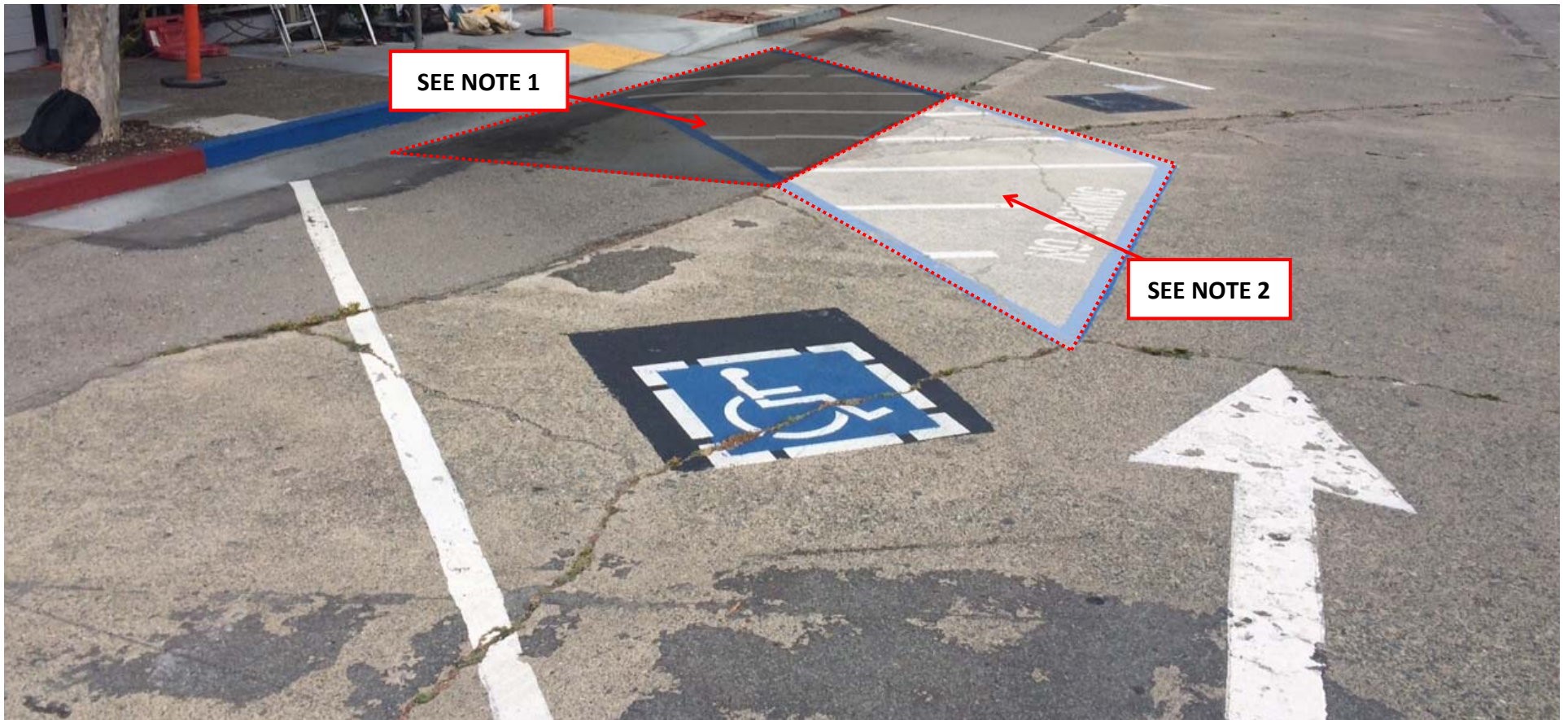

1. Remove 9' x 22' <E> AC. Replace with <N> 6" AC section with maximum 2% slope in all directions.
2. Remove 16' x 7' <E> PCC. Replace with <N> 6" AC section with maximum 2% slope in all directions.
3. Striping by others.

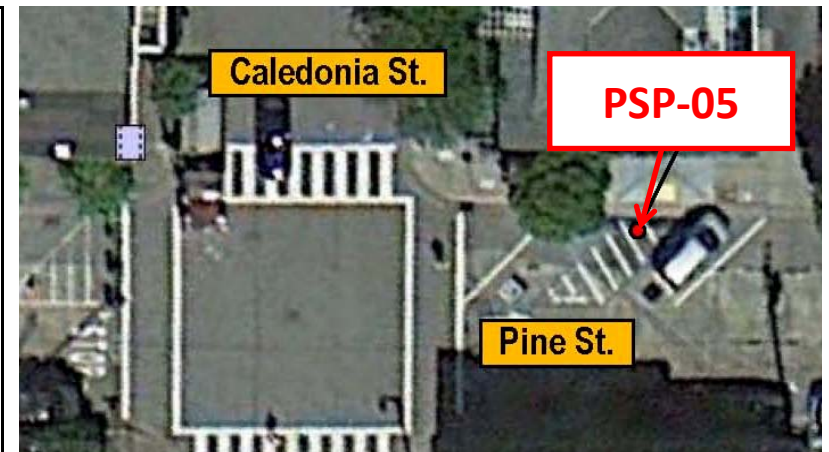



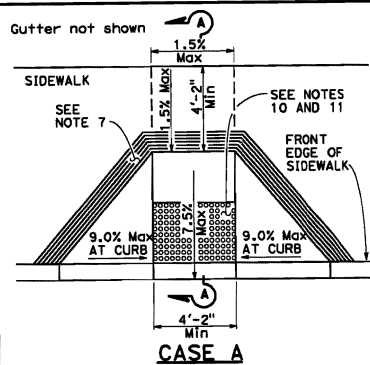

**CASE A**

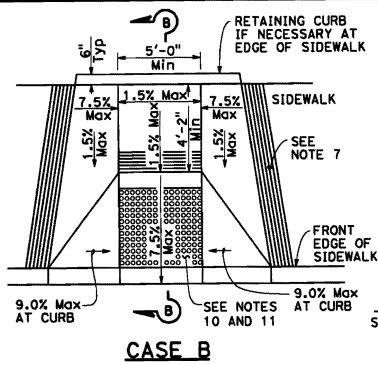

**CASE B**

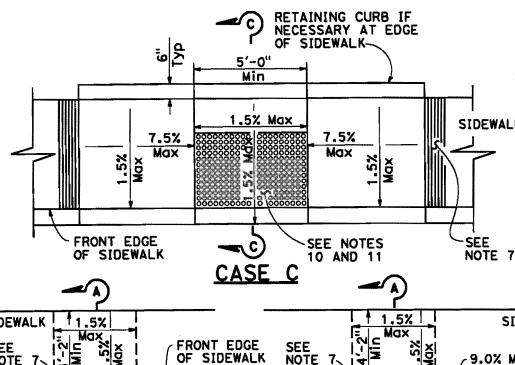

**CASE C**

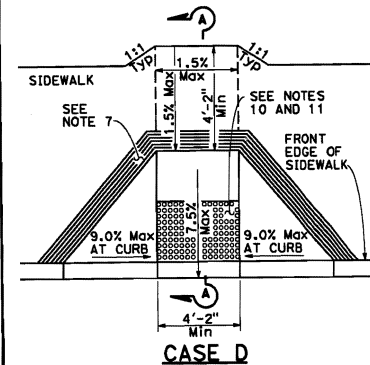

**CASE D**

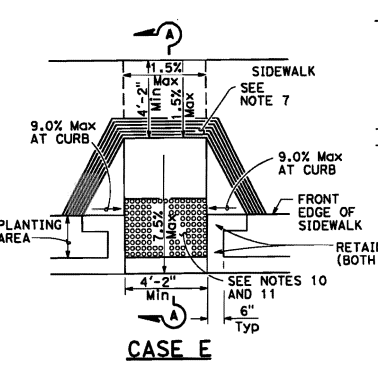

**CASE E**

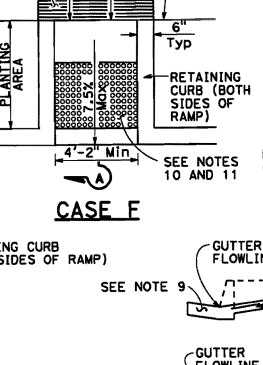

**CASE F**

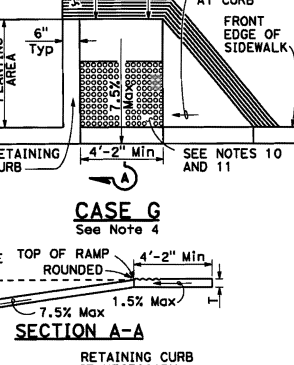

**CASE G**

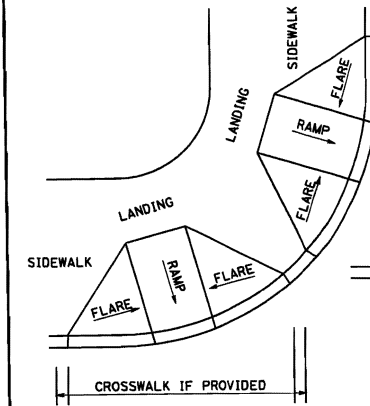

**DETAIL A**

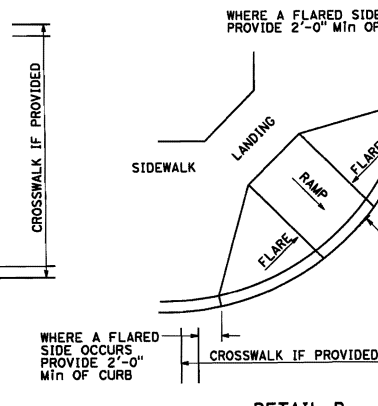

**DETAIL B**

**TYPICAL TWO-RAMP CORNER INSTALLATION**  
See Note 1

**TYPICAL ONE-RAMP CORNER INSTALLATION**  
See Notes 1 and 3

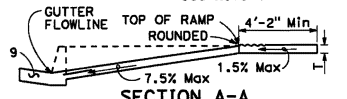

**SECTION A-A**

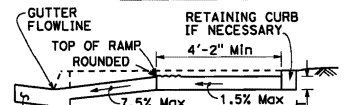

**SECTION B-B**

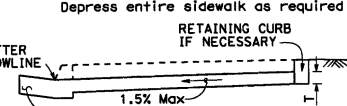

**SECTION C-C**

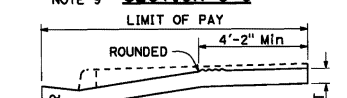

**RETROFIT PAY LIMITS**

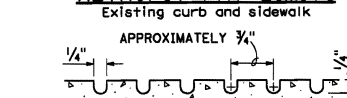

**GROOVING DETAIL**

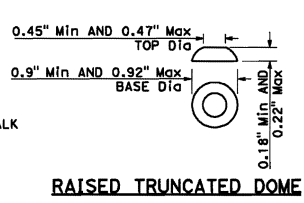

**RAISED TRUNCATED DOME**

**NOTES:**

- As site conditions dictate, Case A through Case G curb ramps may be used for corner installations similar to those shown in Detail A and Detail B. The case of curb ramps used in Detail A do not have to be the same. Case A through Case G curb ramps also may be used at mid block locations, as site conditions dictate.
- If distance from curb to back of sidewalk is too short to accommodate ramp and 4'-2" platform (landing) as shown in Case A, the sidewalk may be depressed longitudinally as in Case B, or C or may be widened as in Case E.
- When ramp is located in center of curb return, crosswalk configuration must be similar to that shown for Detail B.
- As site conditions dictate, the retaining curb side and the flared side of the Case G ramp shall be constructed in reversed position.
- If located on a curve, the sides of the ramp need not be parallel, but the minimum width of the ramp shall be 4'-2".
- Side slope of ramp flares vary uniformly from a maximum of 9.0% at curb to conform with longitudinal sidewalk slope adjacent to top of the ramp, except in Case C and Case F.
- The curb ramp shall be outlined, as shown, with a 1'-0" wide border with 1/4" grooves approximately 3/4" on center. See grooving detail.
- Transitions from ramps and landing to walks, gutters or streets shall be flush (no lip) and free of abrupt changes.
- Counter slopes of adjoining gutters and road surfaces immediately adjacent to and within 24 inches of the curb ramp shall not be steeper than 1:20 (5.0%). Gutter pan slope shall not exceed 1" of depth for each 2'-0" of width.
- Curb ramps shall have a detectable warning surface that extends the full width and 3'-0" depth of the ramp. A 4'-0" wide detectable warning surface may be used on a 4'-2" wide curb ramp. Detectable Warning Surfaces shall conform to the requirements in the Standard Specifications.
- The edge of the detectable warning surface nearest the street shall be between 6" and 8" from the gutter flowline.
- Sidewalk and ramp thickness, "T", shall be 3 1/2" minimum.
- Utility pull boxes, manholes, vaults and all other utility facilities within the boundaries of the curb ramp will be relocated or adjusted to grade by the owner prior to, or in conjunction with, curb ramp construction.
- Detectable warning surface may have to be cut to allow removal of utility covers while maintaining full detectable warning width and depth.

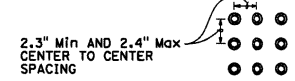

**RAISED TRUNCATED DOME PATTERN (IN-LINE) DETECTABLE WARNING SURFACE**

See Note 10

**CURB RAMP DETAILS**  
NO SCALE

RSP A88A DATED MARCH 21, 2014 SUPERSEDES RSP A88A DATED JULY 19, 2013 AND STANDARD PLAN A88A DATED MAY 20, 2011 - PAGE 121 OF THE STANDARD PLANS BOOK DATED 2010.

**REVISED STANDARD PLAN RSP A88A**

DIST	COUNTY	ROUTE	POST MILES TOTAL PROJECT	SHEET NO.	TOTAL SHEETS

*H. David Cohen*  
REGISTERED CIVIL ENGINEER

March 21, 2014  
PLANS APPROVAL DATE

THE STATE OF CALIFORNIA OR ITS OFFICERS OR AGENTS SHALL NOT BE RESPONSIBLE FOR THE ACCURACY OR COMPLETENESS OF SCANNED COPIES OF THIS PLAN SHEET.

REGISTERED PROFESSIONAL ENGINEER  
**Hector David Cordova**  
No. C41957  
Exp. 3-31-14  
CIVIL  
STATE OF CALIFORNIA

TO ACCOMPANY PLANS DATED \_\_\_\_\_

2010 REVISED STANDARD PLAN RSP A88A

Item #	Location	Standard Curb Ramp <sup>1</sup> SF	Seeded Curb Ramp <sup>1</sup> SF	Concrete Finish <sup>2</sup> TYPE	Curb and Gutter <sup>3</sup> LF	AC SF	TRUNCATED DOMES SF	Grate TYPE	Frame TYPE
BW 15-02	Bridgeway/Napa St., SE	-	-		28	56	-		
BW 15-03	Bridgeway/Napa St., NE	282	-	LW	40	86	15		
BW 15-07	Bridgeway/Off Ramp to Napa St., West	-	-		24	48	-		
BW 15-08	Bridgeway/Off Ramp to Napa St., East	120	-	LW	-	68	33		
BW 15-09	Bridgeway/Napa St., NW	254	-	LW	-	56	30		
BW 15-10	Bridgeway/Napa St., SW	222	-	MW	41	85	15		
BW 16-03	Bridgeway/Bee St., SE	470	-	LW	14	28	39		
BW 18-03	Bridgeway/Locust St., NW	150	-	LW	17	34	12	TYPE C	TYPE C
BW 18-04	Bridgeway/Locust St., NW	100	-	LW	20	40	12		
BW 18-05	Bridgeway/Locust St., SW	-	-		-	-	-	TYPE C	TYPE C
BW 20-02	Bridgeway/Pine St., SE	-	-		37	80	-		
BW 20-03	Bridgeway/Pine St., NE	-	-		33	70	-		
BW 20-08	Bridgeway/Pine St., NW	-	346	SEED	28	112	45	TYPE C	TYPE C
BW 20-09	Bridgeway/Pine St., SW	273	-	LW	32	72	39	TYPE C	TYPE C
BW 21-02	Bridgeway/Johnson St., SE	100	-	LW	20	46	12	TYPE C	TYPE C
BW 21-04	Bridgeway/Johnson St., NE	322	-	LW	40	90	51	TYPE C	TYPE C
BW 21-12	Bridgeway/Johnson St., SW	232	-	LW	33	70	36	TYPE C	TYPE C
BW 22-08	Bridgeway/Caledonia St., NW	150	-	MW	20	46	15	TYPE C	TYPE C
BW 22-09	Bridgeway/Caledonia St., SW	200	-	LW	30	60	12		
PSP-05	Pine/Caledonia St., NE	-	-		-	310	-		
<b>TOTALS</b>		<b>2,875</b>	<b>346</b>		<b>457</b>	<b>1,457</b>	<b>366</b>	<b>8</b>	<b>8</b>

<sup>1</sup> Includes curb ramp, landing area, retaining curbs, and upper landings, and area that is warped to conform to <E> sidewalk (Transition Areas) as required.

<sup>2</sup> BF = Broom Finish  
 LW = Light Wash  
 MW = Medium Wash  
 EA = Exposed Aggregate  
 SEED = Seeded Aggregate

<sup>3</sup> Includes Curb and Gutter along ramps, landings, and transition areas as necessary;  
 Does not include retaining curbs constructed as part of ramp.



**CITY OF SAUSALITO**

**NOTICE TO CONTRACTORS,  
SPECIAL PROVISIONS,  
CONTRACT AND PROPOSAL**

**FOR**

**ACCESSIBILITY IMPROVEMENT PROJECT 2015;  
BID PACKAGE 4B—BRIDGEWAY SOUTH**

**JUNE 2015**

**JONATHON GOLDMAN  
CITY ENGINEER**

**CITY OF SAUSALITO  
420 LITHO STREET  
SAUSALITO, CALIFORNIA**

**TABLE OF CONTENTS**

**Page No.**

TABLE OF CONTENTS..... i

NOTICE TO BIDDERS ..... N-1

**PROPOSAL**

PROPOSAL ..... P-1

CONTRACTOR’S BID ..... P-3

LIST OF SUBCONTRACTORS ..... P-5

EQUAL EMPLOYMENT OPPORTUNITY CERTIFICATION ..... P-6

PUBLIC CONTRACT CODE (Statements, Questionnaire and Noncollusion Affidavit) ..... P-7

CONTRACTOR’S EXPERIENCE STATEMENT ..... P-10

DESIGNATION OF INSURANCE AGENT OR BROKER ..... P-11

STATEMENT OF BIDDER ..... P-12

BIDDER’S BOND ..... P-13

**SPECIAL PROVISIONS**

SPECIAL PROVISIONS ..... SP-1

SECTION 1. SPECIFICATIONS AND PLANS ..... SP-1

SECTION 2. PROPOSAL REQUIREMENTS AND CONDITIONS ..... SP-3

    2-1.01 GENERAL ..... SP-3

    2-1.02 REQUIRED LISTING OF PROPOSED CONTRACTORS ..... SP-3

SECTION 3 AWARD AND EXECUTION OF CONTRACT ..... SP-4

    3-1.01 GENERAL..... SP-4

    3-1.02 BONDS..... SP-4

SECTION 4 BEGINNING OF WORK, TIME OF COMPLETION AND LIQUIDATED DAMAGES ..... SP-5

SECTION 5 GENERAL ..... SP-6

    5-1.01 LABOR NONDISCRIMINATION ..... SP-6

    5-1.02 PUBLIC SAFETY ..... SP-6

    5-1.03 FORCE ACCOUNT PAYMENT ..... SP-7

    5-1.04 PAYMENT OF WITHHELD FUNDS ..... SP-7

    5-1.05 PAYMENTS..... SP-7

    5-1.06 HAZARDOUS WASTE IN EXCAVATION..... SP-7

    5-1.07 SOUND CONTROL REQUIREMENTS ..... SP-7

    5-1.08 WORKING HOURS ..... SP-7

    5-1.09 WATER CONSERVATION ..... SP-8

    5-1.10 SUBCONTRACTING ..... SP-8

    5-1.11 HIGHWAY CONSTRUCTION EQUIPMENT ..... SP-8

    5-1.12 INDEMNITY AND INSURANCE REQUIREMENTS..... SP-9

    5-1.13 ARCHAEOLOGICAL DISCOVERIES..... SP-11

SECTION 6. (BLANK)..... SP-11

SECTION 7. CITY OF SAUSALITO SPECIAL PROVISIONS ..... SP-13

    7-1.01 ENGINEER’S ESTIMATE OF CONSTRUCTION COSTS ..... SP-13

    7-2.01 TERMINATION OF CONTRACT ..... SP-13

    7-3.01 GENERAL..... SP-13

    7-4.01 NOT USED..... SP-15

    7-5.01 MOBILIZATION ..... SP-15

    7-6.01 DEMOLITION ..... SP-15

    7-7.01 TRAFFIC CONTROL ..... SP-17

7-8.01	CONSTRUCTION STAKING .....	SP-19
7-9.01	MINOR CONCRETE (CURB AND GUTTER, CURB RAMPS, SIDEWALKS) .....	SP-19
7-10.01	ASPHALT CONCRETE .....	SP-22
7-11.01	BRICK PAVING INSTALLATION .....	SP-23
7-12.01	CLASS 2 AGGREGATE BASE .....	SP-24
7-13.01	ADJUST COVERS AND FRAMES TO GRADE .....	SP-24
7-14.01	NOT USED.....	SP-24
7-15.01	DETECTABLE WARNING SURFACE .....	SP-24
7-16.01	CATCH BASIN FRAMES AND GRATES.....	SP-24
SECTION 8.	(BLANK) .....	SP-26
SECTION 9.	(BLANK) .....	SP-26
APPLICABLE STANDARD PLANS AND DETAILS .....		SP-27

**CONTRACT**

SAMPLE AGREEMENT .....	C-1
WORKMEN’S COMPENSATION INSURANCE CERTIFICATE.....	C-5
PERFORMANCE BOND.....	C-6
PAYMENT BOND .....	C-8
WARRANTY BOND .....	C-10
ESCROW AGREEMENT .....	C-12
APPENDIX A – RESOLUTION OF CONSTRUCTION CLAIMS .....	C-16

## **ACCESSIBILITY IMPROVEMENT PROJECT 2015—BRIDGEWAY SOUTH NOTICE TO BIDDERS**

**NOTICE IS HEREBY GIVEN** that the City of Sausalito will receive sealed bids for the performance of the Work shown and described in the Plans, Specifications and Contract Documents prepared for the above-designated project. Such sealed bids shall be received at the Office of the City Clerk of the City of Sausalito at 420 Litho Street until **June 10, 2015 at 2:00 PM**, at which time they will be publicly opened and read. On a date to be determined later, such bids shall be tabulated and submitted to the City Council for consideration and action consistent with the provisions of Public Contract Code Division 2, Part 3, Chapter 1, Article 4.

**GENERAL DESCRIPTION OF WORK:** Work under this Contract includes the removal of existing ADA curb ramps, Portland cement concrete sidewalk, curb and gutter and asphaltic concrete roadway paving and replacement with walkway facilities in general compliance with Americans with Disabilities Act (ADA) Guidelines as feasible, as well as replacement of various storm drain catch basin frames and grates to comply with ADA Guidelines.

**PRE-BID MEETING:** Time: 11:30 a.m., Wednesday, June 3, 2015. Location: Dunphy Park parking lot on Bridgeway Blvd. opposite Litho Street. Submit all questions in writing to Andrew Davidson at [ADavidson@ci.sausalito.ca.us](mailto:ADavidson@ci.sausalito.ca.us).

**BIDDERS' REQUIREMENTS:** Each Bid shall be made in accordance with the Plans, Specifications and Contract Documents prepared therefor, available at the Office of the City Engineer where they may be examined and copies thereof be obtained at no cost for the first paper set. A non-refundable cost of twenty five dollars (\$25.00) will be charged for each additional paper set of plans and specifications and they must be ordered and paid for in advance (the City will print to order). Digital copies of the plans and specifications are available on the City website at <http://www.ci.sausalito.ca.us/index.aspx?page=2057>.

Bids shall be submitted only upon proposal forms furnished by the City Engineer. The award of the Contract will be based on the responsible Bidder submitting the lowest qualified responsive Bid. The City Engineer will open the Bids at the time and place above stated and a report will be made to the City Council at a meeting of the Council following the date of opening of the bids.

Each Bid must be accompanied by a Proposal Guarantee in the form of a certified or cashier's check, currency or Bid Bond, equal to ten percent (10%) of the aggregate amount of the Bid. The check or Bond shall be made payable to the City of Sausalito. Any Bid not accompanied by a Bid Security may be rejected. Such amount accompanying the Bid shall be given as a guarantee that the Bidder will enter into the contract if awarded thereto and the Bidder will file the Contract Bonds and other requisite documents required within the specified time period in accordance with the Instruction to Bidders.

All Bids must be addressed to the City Engineer of the City of Sausalito and shall bear the title or name of the work to be constructed.

The City Council reserves the right to reject any and all Bids, and to waive any irregularity in any Bid received. The successful Bidder will be required to pay not less than the general prevailing rate of per diem wages for work of a similar character in the locality in which this public work is performed, and not less than the general prevailing rate of per diem wages for holiday and overtime work shall be paid to all workers employed on this public work. Pursuant to Labor Code, Subsection 1773, the general prevailing rate has been determined by the California Director of the Department of Industrial Relations and copies of such determination are on file in the office of the City Engineer of the City of Sausalito and will be made available to any interested party on request. A copy of these rates shall be posted at the job site by the Contractor. (See California Labor Code sections 1770, 1771, 1772, 1773, 1773.1 and 1773.2.)

Bids will only be accepted from a contractor who is licensed in accordance with the provisions of Chapter 9, Division III of the California Business and Professions Code (BPC). The license required to perform this project is a CLASS "A" (GENERAL ENGINEERING) or Class C-8 Concrete Contractor (BPC Subsection 7000 *et seq.*; Subsection 7028.15).

The time allowed for completion of the project is **Thirty-five (35) Consecutive Working Days** after the start date noted on the NOTICE TO PROCEED. LIQUIDATED DAMAGES for completion after the date prescribed for completion will be **One Thousand Dollars (\$1000.00) PER CALENDAR DAY.** Bidders should have fully inspected the project site in all particulars and become thoroughly familiar with the terms and conditions of the Contract Documents and local conditions affecting the performance and costs of the work prior to submitting a bid. Submission of a Bid by Bidder warrants that Bidder has visited the site of the Project and is thoroughly familiar with the work required of the Contract Documents.

A City of Sausalito Encroachment Permit shall be required and the Encroachment Permit fee shall be waived. A Sausalito Business License is required prior to mobilization. Information about Business Licenses can be found on the City's website: <http://www.ci.sausalito.ca.us/Index.aspx?page=127>.

**Engineer's Estimate:** The Engineer's estimate of construction costs for this project is \$130,000.

**BONDS:** Upon award of the contract, the successful bidder shall furnish a bond for faithful performance in the amount of one hundred percent (100%) of the total bid; it shall also furnish a labor and material bond to secure the payment of all claims of labor and material in the amount of one hundred percent (100%) of the total bid, and a warranty bond in an amount equal to twenty-five percent (25%) of the total bid. Such bonds shall be secured from a surety company satisfactory to the City of Sausalito. No bid or bid security may be withdrawn for 60 calendar days after the bids are opened.

Payment, Performance and Warranty Bonds are required to be filed and approved by the City Engineer before the Contractor begins the Work.

Securities eligible for substitution of Bonds shall be limited to those listed in Government Code Section 16430 or to bank or savings and loan certificates of deposit. Contractor shall be the beneficial owner of any securities so substituted for monies withheld and shall receive any interest or income thereon. Any escrow agreement entered into pursuant to this Section shall contain, as a minimum, the following provisions:

- a) The amount of securities to be deposited.
- b) The terms and conditions of conversion to cash in case of the default of the Contractor; and
- c) The termination of the escrow upon completion of contract.

**RETENTION:** Contract amounts to be paid under this contract will be subject to a ten percent (10%) retention to ensure performance. Pursuant to and subject to the provisions of Public Contract Code (PCC) Subsection 22300, the Contractor shall be entitled to substitute securities for retained monies. The value of any securities so substituted shall be valued by the City's Finance Director, whose decision on the valuation of the securities shall be final.

**CONTRACTOR RESPONSIBILITIES RELATING TO THE DEPARTMENT OF INDUSTRIAL RELATIONS:** 1) No contractor or subcontractor may be listed on a bid proposal for a Public Works project unless registered with the Department of Industrial Relations pursuant to Labor Code section 1725.5 [with limited exceptions from this requirement for bid purposes only under Labor Code section 1771.1 (a)]. 2) No contractor or subcontractor may be awarded a contract for Public Works on a Public Works project (awarded on or after April 1, 2015) unless registered with the Department of Industrial Relations pursuant to Labor Code 1725.5, 3) This project is subject to compliance monitoring and enforcement by the Department of Industrial Relations, and 4) All contractors and subcontractors must furnish electronic certified payroll records directly to the Labor Commissioner (aka Division of Labor Standards Enforcement).

By order of the City Council of the City of Sausalito, County of Marin, State of California.

Dated: June 1, 2015

**CITY OF SAUSALITO**

by: \_\_\_\_\_  
**Jonathon Goldman**  
**Director of Public Works, City Engineer and ADA Coordinator**

**(DO NOT DETACH)**

**PROPOSAL TO THE CITY OF SAUSALITO**

**PUBLIC WORKS DEPARTMENT**

**ACCESSIBILITY IMPROVEMENT PROJECT 2015—BRIDGEWAY SOUTH**

**NAME OF BIDDER** \_\_\_\_\_

**BUSINESS P.O. BOX** \_\_\_\_\_

**CITY, STATE, ZIP** \_\_\_\_\_

**BUSINESS STREET ADDRESS** \_\_\_\_\_

*(Please include even if P.O. Box used)*

**CITY, STATE, ZIP** \_\_\_\_\_

**TELEPHONE NO:**                    **AREA CODE ( )** \_\_\_\_\_

**FAX NO:**                            **AREA CODE ( )** \_\_\_\_\_

**CONTRACTOR LICENSE NO.** \_\_\_\_\_

The work for which this proposal is submitted is for construction in conformance with the special provisions (including the payment of not less than the State general prevailing wage rates or Federal minimum wage rates), the project plans described below, including any addenda thereto, the contract annexed hereto, and also in conformance with the California Department of Transportation Standard Plans, dated May, 2010, the Standard Specifications, dated May, 2010, and the Labor Surcharge and Equipment Rental Rates in effect on the date the work is accomplished.

The plans and special provisions for the work to be done were approved and are titled:

**ACCESSIBILITY IMPROVEMENT PROJECT 2015—BRIDGEWAY SOUTH**

Bids are to be submitted for the entire work. The amount of the bid for comparison purposes will be the total of all items.

The bidder shall set forth for each unit basis item of work a unit price and a total for the item, and for each lump sum item a total for the item, all in clearly legible figures in the respective spaces provided for that purpose. In the case of unit basis items, the amount set forth under the "Item Total" column shall be the product of the unit price bid and the estimated quantity for the item.

In case of discrepancy between the unit price and the total set forth for a unit basis item, the unit price shall prevail, except if the amount set forth as a unit price is unreadable or otherwise unclear, or is omitted, or is the same as the amount as the entry in the item total column, then the amount set forth in the item total column for the item shall prevail and shall be divided by the estimated quantity for the item and the price thus obtained shall be the unit price;

If this proposal shall be accepted and the undersigned shall fail to enter into the contract and furnish the 2 bonds in the sums required by the State Contract Act, with surety satisfactory to the *CITY OF SAUSALITO* within 8 days, not including Saturdays, Sundays and legal holidays, after the bidder has received notice from the *CITY OF SAUSALITO* that the contract has been awarded, the *CITY OF SAUSALITO* may, at its option, determine that the bidder has abandoned the contract, and thereupon this proposal and the acceptance thereof shall be null and void and the forfeiture of the security accompanying this proposal shall operate and the same shall be the property of the *CITY OF SAUSALITO* .

The undersigned, as bidder, declares that the only persons or parties interested in this proposal as principals are those named herein; that this proposal is made without collusion with any other person, firm, or corporation; that he



has carefully examined the location of the proposed work, the annexed proposed form of contract, and the plans therein referred to; and he proposes, and agrees if this proposal is accepted, that he will contract with the *CITY OF SAUSALITO*, in the form of the copy of the contract annexed hereto, to provide all necessary machinery, tools, apparatus and other means of construction, and to do all the work and furnish all the materials specified in the contract, in the manner and time therein prescribed, and according to the requirements of the Engineer as therein set forth, and that he will take in full payment therefore the following prices, to wit:

**CITY OF SAUSALITO  
ACCESSIBILITY IMPROVEMENT PROJECT 2015—BRIDGEWAY SOUTH**

Proposal of \_\_\_\_\_ (hereinafter called "BIDDER"), organized and existing under the laws of the State of \_\_\_\_\_, doing business as \_\_\_\_\_ \*to the CITY OF SAUSALITO (hereinafter called "OWNER").

In compliance with your Advertisement for Bids, BIDDER hereby proposes to perform all WORK for the construction of **ACCESSIBILITY IMPROVEMENT PROJECT 2015—BRIDGEWAY SOUTH** in strict accordance with the CONTRACT DOCUMENTS, within the time set forth therein, and at the prices stated below.

By submission of this BID, each BIDDER certifies, and in the case of a joint BID each party therein certifies as to his own organization, that this BID has been arrived at independently, without consultation, communication, or agreement as to any matter relating to this BID with any other BIDDER or with any competitor.

BIDDER hereby agrees to commence WORK under this contract within five (5) days of the date to be specified in the NOTICE TO PROCEED and to fully complete the PROJECT within thirty-five (35) consecutive working days. BIDDER further agrees to pay as liquidated damages, the sum of \$1,000 for each consecutive working day thereafter as provided in Section 5.06 of the standard specifications.

BIDDER acknowledges receipt of the following ADDENDUM:

\_\_\_\_\_  
\_\_\_\_\_  
\_\_\_\_\_

BIDDER agrees to perform the work described in the CONTRACT DOCUMENTS for the unit prices or lump sum prices stated on the attached BID SCHEDULE.

<b>Item</b>	<b>Description</b>	<b>QTY</b>	<b>UNIT</b>	<b>UNIT PRICE</b>	<b>EXTENDED PRICE</b>
<b>1</b>	Mobilization	<b>1</b>	<b>LS</b>		
<b>2</b>	Traffic Control	<b>1</b>	<b>LS</b>		
<b>3</b>	Demolition	<b>1</b>	<b>LS</b>		
<b>4</b>	Minor Concrete-Curb Ramps, including retaining curbs (if any), and adjacent landings and sidewalk	<b>2875</b>	<b>SF</b>		
<b>5</b>	Minor Concrete-Curb & Gutter	<b>457</b>	<b>LF</b>		
<b>6</b>	Minor Concrete-Curb	<b>4</b>	<b>LF</b>		
<b>7</b>	Detectable Warning Surface Tiles	<b>366</b>	<b>SF</b>		
<b>8</b>	Asphaltic Concrete	<b>1457</b>	<b>SF</b>		
<b>9</b>	Brick Paving	<b>1</b>	<b>LS</b>		
<b>10</b>	Marin UCS Type C catch basin frame/grate	<b>8</b>	<b>EA.</b>		
<b>TOTAL – BASE BID</b>					

\*Insert "a corporation" or "a partnership" or "an individual" as applicable.

Respectfully submitted (Please type or print):

---

Signature

---

Address

---

Title

---

Date

---

License Number (if applicable)

---

Telephone Number

---

SEAL – if BID is by a Corporation

---

attest

The Bidder shall list the name and address of each subcontractor to whom the Bidder proposes to subcontract portions of the work, as required by the provisions in Section 2-1.054, "Required Listing of Proposed Subcontractors," of the Standard Specifications and Section 2-1.01, "General," of the special provisions.

**LIST OF SUBCONTRACTORS**

**Name and Address**

**Description of Portion  
of Work Subcontracted**

*(THE BIDDER'S EXECUTION ON THE SIGNATURE PORTION OF THIS PROPOSAL SHALL ALSO CONSTITUTE AN ENDORSEMENT AND EXECUTION OF THOSE CERTIFICATIONS WHICH ARE A PART OF THIS PROPOSAL)*

**EQUAL EMPLOYMENT OPPORTUNITY CERTIFICATION**

The bidder \_\_\_\_\_, proposed subcontractor \_\_\_\_\_, hereby certifies that he has \_\_\_\_\_, has not \_\_\_\_\_, participated in a previous contract or subcontract subject to the equal opportunity clauses, as required by Executive Orders 10925, 11114, or 11246, and that, where required, he has filed with the Joint Reporting Committee, the Director of the Office of Federal Contract Compliance, a Federal Government contracting or administering agency, or the former President's Committee on Equal Employment Opportunity, all reports due under the applicable filing requirements.

**Note:** The above certification is required by the Equal Employment Opportunity Regulations of the Secretary of Labor (41 CFR 60-1.7(b) (1)), and must be submitted by bidders and proposed subcontractors only in connection with contracts and subcontracts, which are subject to the equal opportunity clause. Contracts and subcontracts which are exempt from the equal opportunity clause are set forth in 41 CFR 60-1.5. (Generally only contracts or subcontracts of \$10,000 or under are exempt.)

Currently, Standard Form 100 (EEO-1) is the only report required by the Executive Orders or their implementing regulations.

Proposed prime contractors and subcontractors who have participated in a previous contract or subcontract subject to the Executive Orders and have not filed the required reports should note that 41 CFR 60-1.7(b) (1) prevents the award of contracts and subcontracts unless such contractor submits a report covering the delinquent period or such other period specified by the Federal Highway Administration or by the Director, Office of Federal Contract Compliance, U.S. Department of Labor.

---

**PUBLIC CONTRACT CODE**

**Public Contract Code Section 10285.1 Statement**

In conformance with Public Contract Code Section 10285.1 (Chapter 376, Stats. 1985), the bidder hereby declares under penalty of perjury under the laws of the State of California that the bidder has \_\_\_ , has not \_\_\_been convicted within the preceding three years of any offenses referred to in that section, including any charge of fraud, bribery, collusion, conspiracy, or any other act in violation of any state or Federal antitrust law in connection with the bidding upon, award of, or performance of, any public works contract, as defined in Public Contract Code Section 1101, with any public entity, as defined in Public Contract Code Section 1100, including the Regents of the University of California or the Trustees of the California State University. The term "bidder" is understood to include any partner, member, officer, director, responsible managing officer, or responsible managing employee thereof, as referred to in Section 10285.1.

Note: The bidder must place a check mark after "has" or "has not" in one of the blank spaces provided. The above Statement is part of the Proposal. Signing this Proposal on the signature portion thereof shall also constitute signature of this Statement. Bidders are cautioned that making a false certification may subject the certifier to criminal prosecution.

---

**Public Contract Code Section 10162 Questionnaire**

In conformance with Public Contract Code Section 10162, the Bidder shall complete, under penalty of perjury, the following questionnaire:

Has the bidder, any officer of the bidder, or any employee of the bidder who has a proprietary interest in the bidder, ever been disqualified, removed, or otherwise prevented from bidding on, or completing a federal, state, or local government project because of a violation of law or a safety regulation?

Yes \_\_\_\_\_ No \_\_\_\_\_

If the answer is yes, explain the circumstances in the following space.

**Public Contract Code 10232 Statement**

In conformance with Public Contract Code Section 10232, the Contractor, hereby states under penalty of perjury, that no more than one final unappealable finding of contempt of court by a federal court has been issued against the Contractor within the immediately preceding two year period because of the Contractor's failure to comply with an order of a federal court which orders the Contractor to comply with an order of the National Labor Relations Board.

Note: The above Statement and Questionnaire are part of the Proposal. Signing this Proposal on the signature portion thereof shall also constitute signature of this Statement and Questionnaire.

Bidders are cautioned that making a false certification may subject the certifier to criminal prosecution.

---

**Noncollusion Affidavit**

(Title 23 United States Code Section 112 and  
Public Contract Code Section 7106)

TO THE CITY OF SAUSALITO  
DEPARTMENT OF PUBLIC WORKS

In accordance with Title 23 United States Code Section 112 and Public Contract Code 7106 the bidder declares that the bid is not made in the interest of, or on behalf of, any undisclosed person, partnership, company, association, organization, or corporation; that the bid is genuine and not collusive or sham; that the bidder has not directly or indirectly induced or solicited any other bidder to put in a false or sham bid, and has not directly or indirectly colluded, conspired, connived, or agreed with any bidder or anyone else to put in a sham bid, or that anyone shall refrain from bidding; that the bidder has not in any manner, directly or indirectly, sought by agreement, communication, or conference with anyone to fix the bid price of the bidder or any other bidder, or to fix any overhead, profit, or cost element of the bid price, or of that of any other bidder, or to secure any advantage against the public body awarding the contract of anyone interested in the proposed contract; that all statements contained in the bid are true; and, further, that the bidder has not, directly or indirectly, submitted his or her bid price or any breakdown thereof, or the contents thereof, or divulged information or data relative thereto, or paid, and will not pay, any fee to any corporation, partnership, company association, organization, bid depository, or to any member or agent thereof to effectuate a collusive or sham bid.

Note: The above Noncollusion Affidavit is part of the Proposal. Signing this Proposal on the signature portion thereof shall also constitute signature of this Noncollusion Affidavit.

Bidders are cautioned that making a false certification may subject the certifier to criminal prosecution.





**DESIGNATION OF INSURANCE AGENT OR BROKER**

It is proposed that the following insurance agent or broker will provide policies of insurance or insurance certificates as are required by the General Provisions.

Insurance Agent or Broker \_\_\_\_\_

Street \_\_\_\_\_

City, Zip \_\_\_\_\_

Telephone \_\_\_\_\_

**STATEMENT OF BIDDER**

Please state whether you, or any officer of yours, or any employee of yours who may have a proprietary interest in your bid, have ever been disqualified, removed, or otherwise prevented from bidding on or completing a federal, state, or local government project because of a violation of law or safety regulations.

YES \_\_\_\_\_ NO \_\_\_\_\_

If your answer is yes, explain the circumstances.

I declare under penalty of perjury that the foregoing information is true and correct.

Executed at \_\_\_\_\_ on \_\_\_\_\_  
\_\_\_\_\_, 2015

\_\_\_\_\_

CITY OF SAUSALITO  
DEPARTMENT OF PUBLIC WORKS

**BIDDER'S BOND**

We, \_\_\_\_\_  
\_\_\_\_\_ as Principal, and

\_\_\_\_\_ as Surety are bound unto the City of Sausalito, State of California, hereafter referred to as "Obligee", in the penal sum of ten percent (10%) of the total amount of the bid of the Principal submitted to the Obligee for the work described below, for the payment of which sum we bind ourselves, jointly and severally,

THE CONDITION OF THIS OBLIGATION IS SUCH, THAT:

WHEREAS, the Principal is submitted to the Obligee, for \_\_\_\_\_

\_\_\_\_\_  
*(Copy here the exact description of work, including location as it appears on the proposal)*

for which bids are to be opened at \_\_\_\_\_ on \_\_\_\_\_  
*(Insert place where bids will be opened) (Insert date of bid opening)*

NOW, THEREFORE, if the Principal is awarded the contract and, within the time and manner required under the specifications, after the prescribed forms are presented to him for signature, enters into a written contract, in the prescribed form, in conformance with the bid, and files two bonds with the Obligee, one to guarantee faithful performance of the contract and the other to guarantee payment for labor and materials as provided by law, then this obligation shall be null and void; otherwise, it shall remain in full force.

In the event suit is brought upon this bond by the Obligee and judgement is recovered, the Surety shall pay all costs incurred by the Obligee in such suit, including a reasonable attorney's fee to be fixed by the court.

Dated: \_\_\_\_\_, 20\_\_\_\_.

\_\_\_\_\_  
\_\_\_\_\_  
*Principal*  
\_\_\_\_\_  
*Surety*  
By \_\_\_\_\_  
*Attorney-in-fact*

**CERTIFICATE OF ACKNOWLEDGEMENT**

State of California  
City/County of \_\_\_\_\_ SS

On this \_\_\_\_\_ day of \_\_\_\_\_ in the year 20 \_\_\_\_\_ before me \_\_, personally appeared \_\_\_\_\_, *Attorney-in-fact*, personally known to me (or proved to me on the basis of satisfactory evidence) to be the person whose name is subscribed to this instrument as the *attorney-in-fact* of \_\_\_\_\_, and acknowledged to me that he (she) subscribed the name of the said company thereto as surety, and his (her) own name as attorney-in-fact.

(SEAL) \_\_\_\_\_  
*Notary* *Public*

**CITY OF SAUSALITO  
PUBLIC WORKS DEPARTMENT**

---

**SPECIAL PROVISIONS**

---

**SECTION 1. SPECIFICATIONS AND PLANS**

The work embraced herein shall be done in accordance with documents included and listed as Bid Package 4B – Bridgeway South and the Standard Specifications dated May 2010, and the Standard Plans dated May 2010, of the State of California Department of Transportation insofar as the same may apply and in accordance with the following Special Provisions.

In case of conflict between the Standard Specifications and these Special Provisions, the Special Provisions shall take precedence over and be used in lieu of such conflicting portions.

**DEFINITIONS AND TERMS**

As used herein, unless the context otherwise requires, the following terms have the following meaning:

**DEPARTMENT OF TRANSPORTATION**

City Council of the City of Sausalito, State of California.

**DIRECTOR OF TRANSPORTATION**

City Council of the City of Sausalito, State of California.

**ENGINEER**

The Director of Public Works of the City of Sausalito acting either directly or through properly authorized agents, such agents acting within the scope of the particular duties entrusted to them.

**LABORATORY**

The established laboratory of the Materials and Research Department of the Department of Transportation of the State of California or laboratories authorized by the Engineer to test materials and work involved in the contract.

**CITY**

The City of Sausalito.

**STANDARD SPECIFICATIONS**

The 2010 edition of the Standard Specifications of the State of California, Department of Transportation. Any reference therein to the State of California or a State agency, office, or officer shall be interpreted to refer to the City or its corresponding agency, office, or officer acting under this contract.

**STANDARD PLANS**

---

Standard Plans shall mean the standard plans of the State of California, Business and Transportation Agency, Department of Transportation dated May 2010.

**UNIFORM CONSTRUCTION STANDARDS**

Uniform Construction Standards shall mean the Uniform Construction Standards approved and adopted by the Cities of Marin and County of Marin in May 2008.

**CONTRACT DOCUMENTS**

The work shall conform to the requirements of all the following contract documents:

- Project Plans.
- These specifications, including the Notice to Contractors
- The Standard Specifications, insofar as they may apply.
- The Standard Plans, insofar as they may apply.
- The Uniform Construction Standards, insofar as they may apply.
- The Proposal and the Contract (or Agreement).
- The contract bond required herein.
- Any supplemental agreements amending or extending the work.
- Any working drawings, sketches, or instructions clarifying or enlarging upon the work specified herein.
- Pertinent portions of any other documents included by reference thereto in these specifications, the Standard Specifications, or the Plans.

**SEE PAGE SP-14 FOR PRIORITY OF CONTRACT DOCUMENTS**

**IN CASE OF CONFLICT BETWEEN THE STANDARD SPECIFICATIONS AND THESE FOLLOWING PROVISIONS, THESE PROVISIONS SHALL TAKE PRECEDENCE OVER AND BE USED IN LIEU OF SUCH CONFLICTING PORTIONS. IT IS THE INTENT OF THIS CONTRACT TO OBTAIN A FINISHED, PROFESSIONAL JOB, COMPLETE IN PLACE AND IN CONFORMANCE WITH ALL APPLICABLE CODES AND REGULATIONS.**

## **SECTION 2. PROPOSAL REQUIREMENTS AND CONDITIONS**

### **2-1.01 GENERAL**

The bidder's attention is directed to the provisions in Section 2, "Proposal Requirements and Conditions," of the Standard Specifications and these Special Provisions for the requirements and conditions which he/she must observe in the preparation of the proposal form and the submission of the bid.

The last sentence in Section 21.01, "Contents of Proposal Forms," of the Standard Specifications is deleted.

After the fifth paragraph of Section 21.03, "Examination of Plans, Specifications, Contract, and Site of Work," the following is added:

When cross sections are included with the contract plans, it is expressly understood and agreed that said cross sections do not constitute part of the contract, do not necessarily represent actual site conditions or show location, character, dimensions and details of work to be performed, and are included in the plans only for the convenience of bidders and their use is subject to all the conditions and limitations set forth in Section 21.03.

When cross sections are not included in the plans, but are available, Bidders or Contractors may inspect such cross sections and obtain copies for their use, at their expense.

The first sentence of the second paragraph in Section 21.05, "Proposal Forms," of the Standard Specifications is amended to read:

The proposal form is bound together with the contract.

The last paragraph in Section 21.07, "Proposal Guaranty," of the Standard Specifications is amended to read:

The bidder's bond shall be issued to the "City of Sausalito," and in the usual form of the surety.

### **2-1.02 REQUIRED LISTING OF PROPOSED SUBCONTRACTORS**

Each proposal shall have listed therein the name and address of each subcontractor to whom the bidder proposes to subcontract portions of the work in the amount of 1/2 of one percent of his total bid or \$10,000, whichever is greater, in accordance with the Subletting and Subcontracting Fair Practices Act, commencing with Section 4100 of the Public Contract Code. The bidder's attention is invited to other provisions of said Act related to the imposition of penalties for a failure to observe its provisions by using unauthorized subcontractors or by making unauthorized substitutions.

**A SHEET FOR LISTING THE SUBCONTRACTORS, AS REQUIRED HEREIN, IS INCLUDED IN THE PROPOSAL.**

## **SECTION 3. AWARD AND EXECUTION OF CONTRACT**

### **3-1.01 GENERAL**

The bidder's attention is directed to the provisions in Section 3, "Award and Execution of Contract," of the Standard Specifications and these Special Provisions. The award of contract, if it be awarded, will be to the lowest responsible bidder whose proposal complies with all the requirements prescribed, and shall be based on budget requirements. If awarded the contract shall be made to the lowest bidder based on the Base Bid Total.

Before the contract is awarded, the Director of Public Works may, at his discretion, require from the proposed Contractor further evidence of qualification, ability to perform, and financial responsibility; and the City Council may consider such evidence in making its decision on the award of the proposed contract.

### **3-1.02 BONDS**

Contractor shall provide, at the time of the execution of the agreement or contract for the work, and at his/her own expense, a surety bond in an amount equal to at least one hundred percent (100%) of the contract price as security for the faithful performance of said agreement. Contractor shall also provide, at the time of the execution of the agreement or contract for the work, and at his/her own expense, a separate surety bond in an amount equal to at least one hundred percent (100%) of the contract price as security for the payment of all persons performing labor and furnishing materials in connection with said agreement and a warranty bond in an amount equal to twenty-five percent (25%) of the total bid. Sureties on each of said bonds shall be satisfactory to the City Attorney.



## **SECTION 4. BEGINNING OF WORK, TIME OF COMPLETION AND LIQUIDATED DAMAGES**

### **4-1.01 General**

Project involves the removal of Portland Cement Concrete sidewalk, curb and gutter and associated asphaltic concrete and its replacement with walkway facilities, as well as some storm drain catch basin frames and grates, in general compliance with Americans with Disabilities Act Guidelines as feasible and as described in the Plans and these Specifications.

### **4-1.02 Changes**

The Contractor is notified that the Engineer's authority for approving Change Orders is limited to 10 percent of the project cost. Amounts in excess of this limit will require approval by the Sausalito City Council with requisite time to schedule change order reviews and to process approvals.

### **4.03 Beginning of Work, Time of Completion and Liquidated Damages**

Attention is directed to provisions 8.103, "Beginning of Work," in Section 8-1.06, "Time of Completion," and in Section 8-1.07, "Liquidated Damages," of the State of California Standard Specifications and these special provisions.

The Contractor shall begin work after the contract has been approved by City of Sausalito staff authorized to execute the contract on behalf of the City (typically the City Manager) and whose form has been approved by the City Attorney of the City of Sausalito.

This work shall be diligently prosecuted to completion before the expiration of **35 WORKING DAYS** beginning on the date determined in the Notice to Proceed.

The Contractor shall pay to the City of Sausalito the sum of **\$1,000** per day, for each and every calendar day delay in finishing the work in excess of the number of working days prescribed above.

## **SECTION 5. GENERAL**

### **5-1.01 LABOR NONDISCRIMINATION**

Attention is directed to the following Notice that is required by Chapter 5 of Division 4 of Title 2, California Administrative Code.

#### **NOTICE OF REQUIREMENT FOR NONDISCRIMINATION PROGRAM (GOVERNMENT CODE, Section 12990)**

Your attention is called to the "Nondiscrimination Clause," set forth in Section 7-1.01A(4), "Labor Nondiscrimination," of the Standard Specifications, which is applicable to all nonexempt state contracts and subcontracts, and the "Standard California Nondiscrimination Construction Contract Specifications" set forth therein. The Specifications are applicable to all nonexempt state construction contracts and subcontracts of \$5,000 or more.

### **5-1.02 PUBLIC SAFETY**

In addition to any other measures taken by the Contractor, pursuant to the provisions of Section 7-1.09, "Public Safety," of the Standard Specifications, the Contractor shall install temporary railing (Type K) between any lane carrying public traffic and any excavation, obstacle, or storage area when the following conditions exist:

- 1. Excavation.** Any excavation the near edge of which is 12 feet or less from the edge of the lane, except:
  - (a) Excavations covered with sheet steel or concrete covers of adequate thickness and adequately secured to prevent accidental entry by traffic or the public.
  - (b) Excavations less than one foot deep.
  - (c) Trenches less than one foot wide for irrigation pipe or electrical conduit or excavations less than one foot in diameter.
  - (d) Excavations parallel to the lane for the purpose of pavement widening or reconstruction.
  - (e) Excavations in side slopes, where the slope is steeper than 4:1.
  - (f) Excavations protected by existing barrier or railing.
- 2. Temporarily Unprotected Permanent Obstacles.** Whenever the work includes the installation of a fixed obstacle together with a protective system, such as a sign structure together with protective railing, and the Contractor elects to install the obstacle prior to installing the protective system; or whenever the Contractor, for his convenience and with permission of the Engineer, removes a portion of an existing protective railing at an obstacle and does not replace such railing complete in place during the same day.
- 3. Storage Areas.** Whenever material or equipment is stored within 12 feet of the lane and such storage is not otherwise prohibited by the specifications.

When traffic cones or delineators are used to delineate a temporary edge of traffic lane, the line of cones or delineators shall be considered to be the edge of traffic lane, however, the Contractor shall not reduce the width of an existing lane to less than 10 feet without written approval from the Engineer. The lane closure provisions of this section shall not apply if the work area is protected by permanent or temporary railing or barrier.

When work is not in progress on a trench or other excavation that required a lane closure, the traffic cones or portable delineators used for the lane closure shall be placed off of and adjacent to the edge of the traveled way. The spacing of the cones or delineators shall be not more than the spacing used for the lane closure.

### **5-1.03 FORCE ACCOUNT PAYMENT**

Attention is directed to Section 9-1.03A, "Work Performed by Contractors," of the Standard Specifications and these Special Provisions.

### **5-1.04 PAYMENT OF WITHHELD FUNDS**

Attention is directed to Section 9-1.065, "Payment of Withheld Funds," of the Standard Specifications and these Special Provisions.

### **5-1.05 PAYMENTS**

Attention is directed to Section 9-1.06, "Partial Payments," and 9-1.07, "Payment after Acceptance," of the Standard Specifications and these Special Provisions.

No partial payments will be made for any materials on hand, which are furnished but not incorporated in the work.

### **5-1.06 HAZARDOUS WASTE IN EXCAVATION**

If the Contractor encounters material in excavation which he has reason to believe may be hazardous waste, as defined by Section 25117 of the Health and Safety Code, he shall immediately so notify the Engineer in writing. Excavation in the immediate area of the suspected hazardous material shall be suspended until the Engineer authorizes it to be resumed.

If such suspension delays the current controlling operation more than two (2) working days, the delay will be considered a right of way delay and the Contractor will be compensated for such delay as provided in Section 8-1.09, "Right of Way Delays," of the Standard Specifications.

The City Engineer reserves the right to use other forces for exploratory work to identify and determine the extent of such material and for removing hazardous material from such area.

### **5-1.07 SOUND CONTROL REQUIREMENTS**

Sound Control shall conform to the provisions in Section 71.011, "Sound Control Requirements," of the Standard Specifications and these Special Provisions.

Said noise level requirement shall apply to all equipment on the job or related to the job, including but not limited to trucks, transit mixers or transient equipment that may or may not be owned by the Contractor. The use of loud sound signals shall be avoided in favor of light warnings except those required by safety laws for the protection of personnel.

### **5-1.08 WORKING HOURS**

City inspection personnel will be available as required during normal **working hours from 8:00 a.m. to 5:00 p.m. on Monday thru Friday**. In the event that the Contractor wishes to schedule overtime work after 5:00 p.m. or before 8:00 a.m. on Monday thru Friday, or at any time on Saturdays, Sundays or holidays, arrangements shall be made with the City Engineer at least forty-eight (48) hours in advance of such overtime work. In the event that the City Engineer is unable to schedule the necessary personnel the Contractor's request may be denied and no work shall be performed outside of normal working hours unless the work is of an emergency nature. The Contractor shall compensate the City for work done by City personnel outside of normal working hours (8:00 a.m. to 5:00 p.m.) Compensation shall be actual cost plus 15% and shall be deducted from the total amount from various pay items and no additional compensation will be allowed.

### **5-1.09 WATER CONSERVATION**

Attention is directed to the various sections of the Standard Specifications and these Special Provisions which require the use of water for the construction of this project. Attention is also directed to the provisions of Section 7, "Legal Relations and Responsibility," of the Standard Specifications with regards to the Contractor's responsibilities for public convenience, public safety, preservation of property and responsibility of damage.

Nothing in this section, "Water Conservation," shall be construed as relieving the Contractor from furnishing an adequate supply of water required for the proper construction of this project in accordance with the Standard Specifications or these Special Provisions or relieving the Contractor from the legal responsibilities defined in said Section 7.

The Contractor shall, whenever possible and not in conflict with the above requirements, minimize the use of water during construction of the project. Watering equipment shall be kept in good working order; water leaks shall be repaired promptly; and washing of equipment, except when necessary for safety or for the protection of equipment, shall be discouraged.

Minor concrete structures and miscellaneous concrete construction shall not be cured by using water.

When ordered by the Engineer, a dust palliative conforming to the provisions of Section 18, "Dust Palliative," of the Standard Specifications shall be used to control dust on this project. Dust palliative ordered by the Engineer will be paid for as extra work in accordance with Section 4-1.03D of the Standard Specifications.

Attention is directed to Section 17-1.025, "Chemical Additives," of the Standard Specifications. When ordered by the Engineer, a chemical additive shall be added to water used for compaction. The additive shall be approved by the Engineer and shall be used in accordance with his instructions. Chemical additive ordered by the Engineer will be paid for as extra work in accordance with Section 4-1.03D of the Standard Specifications.

### **5-1.10 SUBCONTRACTING**

Attention is directed to the provisions in Section 8-1.01, "Subcontracting," of the Standard Specifications, Section 2, "Proposal Requirements and Conditions," and Section 3, "Award and Execution of Contract," elsewhere in these Special Provisions.

A sheet for listing the subcontractors, as required by the Subletting and Subcontracting Fair Practices Act, is included in the proposal.

### **5-1.11 HIGHWAY CONSTRUCTION EQUIPMENT**

Attention is directed to Sections 7-1.01D, "Vehicle Code," and 7-1.02, "Weight Limitations," of the Standard Specifications and these Special Provisions.

Pursuant to the authority contained in Section 591 of the Vehicle Code, the Department has determined that, within such areas as are within the limits of the project and are open to public traffic, the Contractor shall comply with all the requirements set forth in Divisions 11, 12, 13, 14 and 15 of the Vehicle Code. Attention is directed to the statement in Section 591 that this section shall not relieve him or any person from the duty of exercising due care. The Contractor shall take all necessary precautions for safe operation of his equipment and the protection of the public from injury and damage from such equipment.

## 5-1.12 INDEMNITY AND INSURANCE REQUIREMENTS.

### Indemnity and Insurance Requirements

For the purpose of this Section "Indemnity and Insurance Requirements," "City" shall mean the City of Sausalito, which is the public entity awarding this contract by action of the City Council sitting as the governing body of such public entity.

1. **Indemnity.** Contractor shall effectively protect and guard City, its officers, agents and employees, from any liability as a consequence of any willful act, negligent act or non-negligent act or omission by the Contractor, and of the Contractor's employees or agents, or any subcontractor, and shall be responsible for any and all damage, injury, or death to persons, or damage to property. Contractor shall indemnify, defend and hold City from any and all claims, suits, actions, costs, and liability ensuing in connection with the performance of the contract, or failure to protect the safety of workers or the general public, regardless of the existence of or degree of fault or negligence on the part of the City or the Contractor, subcontractor, or any employee of any of these, other than the active negligence of the City, its officers, or employees.

In those instances where the City has obtained "Right of Entry" from private property owners upon whose property it will be necessary for the Contractor to enter to perform the work to be done under the contract, Contractor shall indemnify such property owners in the same manner as the City is indemnified.

2. **Insurance Requirements.** Contractor shall procure and maintain, for the duration of the contract, insurance against claims for injuries to persons or damages to property which may arise from or in connection with the performance of the work hereunder by the Contractor, his agents, representatives, employees or subcontractors. The cost of such insurance shall be included in the Contractor's bid.

Said policies shall be in effect until final acceptance by City and shall provide that they may not be canceled without first providing City with thirty (30) days written notice of such intended cancellation. If Contractor fails to maintain the insurance provided herein, City may secure such insurance and deduct that cost thereof from any funds owing to Contractor.

(a) Minimum Scope of Insurance. Coverage shall be at least as broad as:

- i. Insurance Services Office Commercial General Liability coverage ("occurrence" form CG 00 01 or equivalent or "claims made" form CG 00 02 or equivalent) **NOTE: "claims made" coverage requires special approval and "modified occurrence" coverage is unacceptable.**
- ii. Insurance Service Office form number CA 00 01 (Ed. 01/87 or equivalent) covering Automobile Liability, Code 1 "any auto" with endorsement CA 00 29 (auto contractual).
- iii. Workers' Compensation insurance as required by the State of California and Employers Liability Insurance.

(b) Minimum Limits of Insurance. Contractor shall maintain limits of no less than:

- i. General Liability: \$2,000,000 per occurrence for bodily injury, personal injury and property damage. If Commercial General Liability insurance or other form with a general aggregate limit is used, either the general aggregate limit shall apply separately to this project or the general aggregate limit shall be twice the required occurrence limit.

- ii. Automobile Liability: \$1,000,000 per accident for bodily injury and property damage.
  - iii. Employers' Liability: \$1,000,000 per accident for bodily injury or disease.
- (c) Deductibles and Self-Insured Retentions. Any deductibles or self-insured retentions must be declared to and approved by the City of Sausalito. At the option of the City, either the insurer shall reduce or eliminate such deductibles or self-insured retentions as respects the City, its officials, employees and volunteers, or the Contractor shall provide a financial guarantee satisfactory to the City guaranteeing payment of losses and related investigations, claim administration and defense expenses.
- (d) Other Insurance Provisions. The general liability policy is to contain, or be endorsed to contain, the following provisions:
- i. The City of Sausalito, its officials, employees and volunteers are to be covered as insured with respect to liability arising out of work or operations performed by or on behalf of the Contractor including materials, parts or equipment furnished in connection with such work or operations. General liability coverage can be provided in the form of an endorsement to the Contractor's insurance (using either the County of Marin's prepared form or using ISO form CG 20 10 11 85 or equivalent).
- Any failure to comply with reporting provisions of the policies shall not affect coverage provided to the City, its officials, employees and volunteers or other insured under this contract.
- ii. For any claims related to this project, the Contractor's insurance coverage shall be primary insurance as respects the City, its officials, employees or volunteers. Any insurance or self-insurance maintained by the City shall be excess of the Contractor's insurance and shall not contribute with it.
  - iii. The workers' compensation policy shall contain a waiver of subrogation in favor of the City.
  - iv. Each insurance policy required by this clause shall be endorsed to state that coverage shall not be canceled by either party, except after thirty days prior written notice (10 days for non-payment of premium) by certified mail, return receipt requested has been given to the City of Sausalito, (Attention) Department of Public Works, 420 Litho Street, CA 94965.
- (e) Rights of Entry. If applicable, all private property owners granting "Rights of Entry" for construction of the work shall be covered as insureds under the same coverage as provided the City as respects their ownership of the property and the work to be done thereon.
- (f) Acceptability of Insurers. Insurance is to be placed with insurers with a current A.M. Best's rating of no less than A:VII. Carriers not licensed in the State of California should have a current A.M. Best's rating of no less than A:VII.
- (g) Verification of Coverage. Contractor shall furnish the City with original certificates and amendatory endorsements effecting coverage required by this clause. The endorsements should be on forms provided by the County of Marin or on other than the County of Marin's forms, provided those endorsements or policies conform to the requirements. All certificates and endorsements are to be received and approved by the City **before work commences**. The City reserves the right to require complete, certified copies of all

required insurance policies, including endorsements affecting the coverage required by these specifications at any time.

- (h) Subcontractors. Contractor shall require all its subcontractors to name contractor and City of Sausalito as additional insureds under its policies and contractor shall require all its subcontractors to furnish separate certificates and endorsements for each subcontractor. All coverages for subcontractors shall be subject to all of the requirements stated herein.

### **5-1.13 ARCHAEOLOGICAL DISCOVERIES**

All articles of archaeological interest which may be uncovered by the Contractor during the progress of the work shall be reported immediately to the Engineer. The further operations of the Contractor with respect to the find will be decided under the direction of the Engineer.

### **SECTION 6. (BLANK)**

**Special Provisions**

for

**ACCESSIBILITY IMPROVEMENT PROJECT 2015;  
BID PACKAGE 4B—BRIDGEWAY SOUTH**

**Sausalito, CA**

**Prepared by**

**Jonathon Goldman  
City Engineer  
City of Sausalito  
420 Litho Street  
Sausalito, California**

**June 2015**



## **SECTION 7. CITY OF SAUSALITO SPECIAL PROVISIONS**

### **7-1.01 ENGINEER'S ESTIMATE OF CONSTRUCTION COSTS**

The Engineer's estimate of construction costs for this project is \$130,000 (total).

### **7-2.01 TERMINATION OF CONTRACT**

The City reserves the right to terminate the contract at any time upon a determination by the City Engineer that termination of the contract is in the best interests of the City.

If the City Engineer elects to terminate the contract, the termination of the contract and the compensation payable to the Contractor shall be governed by Section 8-1.11, paragraphs A through D, of the State of California Standard Specifications.

### **7-3.01 GENERAL**

**LOCATION OF PROJECT.** The Project is located in the City of Sausalito, and includes work at various City Streets shown in the plans on Bridgeway Blvd. from Napa Street to Johnson Street, including portions of some intersecting streets.

**SCOPE OF WORK.** Project includes but is not limited to the removal of existing ADA ramps, Portland cement concrete sidewalk, curb and gutter, and asphaltic concrete roadway paving and its replacement with walkway facilities in general compliance with Americans with Disabilities Act (ADA) Guidelines as feasible, as well as replacement of various storm drain catch basin frames and grates to comply with ADA Guidelines.

**LIMITS OF WORK.** The approved working limits are shown in the project plans.

**SUBMITTALS.** The Contractor shall submit the following:

1. **Encroachment Permit Application.** An application may be viewed and downloaded from the City of Sausalito's website: <http://www.ci.sausalito.ca.us/Index.aspx?page=188>.
2. **Construction Schedule.** A proposed construction schedule shall be submitted at the pre-construction meeting. The schedule shall be updated, and submitted at the weekly construction meetings. Schedule may be CPM, or a Bar Chart Schedule, but must include all major work items and show all interrelationships.
3. **Traffic Control Plan.** A traffic control plan shall be submitted to the Engineer at the pre-construction meeting or prior to start of work. This plan must be approved by the City prior to start of work and will explain how the Contractor will control vehicular traffic during the life of the project. In this plan Contractor shall identify how the conduct of the Work will take place with minimum impact to vehicular traffic.
4. **Pedestrian Control Plan.** A temporary pedestrian traffic control plan shall be submitted to the City Engineer at the pre-construction meeting or prior to start of work. The plan must be approved by the City prior to start of work. This plan will show how the Contractor will detour and control pedestrian traffic by providing temporary ADA access during construction of permanent facilities.

### **RESPONSIBILITIES TO THE PUBLIC**

No street may be completely closed to through traffic at any time unless permitted in writing by the Engineer. The Contractor shall post warning signs near each end of work limits as detailed in traffic control plan approved by the Engineer and as otherwise directed by the Engineer.

Traffic control and construction warning devices shall be provided in conformance with the latest edition of the CALIFORNIA MANUAL ON UNIFORM TRAFFIC CONTROL DEVICES PART 6, TEMPORARY TRAFFIC CONTROL, a copy of which shall be on the site at all times during work periods.

PROTECTION OF EXISTING FACILITIES. The Contractor shall protect in place all existing facilities (including, but not limited to street signs, parking meters, and pavement striping) within or adjacent to the limits of work that are not a part of the project. All damaged facilities shall be repaired or replaced as directed by the Engineer. All costs associated with protecting, repairing and/or replacing these facilities shall be the sole responsibility of the Contractor.

PRIORITY OF PROJECT DOCUMENTS. The contract documents for this project are listed below and if there is a conflict between contract documents, the document first in order shall control. The precedence shall be as follows:

1. **Construction Contract**
2. **Bid Proposal**
3. **Instruction to Bidders**
4. **Project Plans**
5. **City of Sausalito Special Provisions**
6. **Special Provisions**
7. **Cities and County of Marin General Provisions**
8. **Cities and County of Marin Standard Plans**
9. **State of California Standard Specifications**
10. **State Standard Plans**

PROJECT MEETINGS. In order to effectively manage the construction process, the City may require that meetings be held during the course of the Work at which time all members of the building team are expected to attend.

As soon as the City has obtained the Contractor's executed bonds and certificate of insurance, a pre-construction meeting will be held. At that time, representatives of the City and the Contractor, will discuss in detail certain procedural aspects of the Work, including:

1. Administrative procedures for transmittals, approvals, change orders and similar items;
2. Review of the method of application for payment, progress payments, retention, and final payment;
3. Review of the Contractor's construction schedule, list of proposed subcontractors, and the schedule of values.
4. Review of Contractor's traffic control plan and temporary pedestrian control plan.
5. Inspection of Contractor's work.

The City reserves the right to call meetings spontaneously when it believes necessary in order to effectively manage work on the Project, to prevent misunderstandings, or to disseminate information.

CONTRACTOR'S LICENSE REQUIREMENTS. Contractor's License Classification – In accordance with the provisions of California Public Contract Code Section 3300, the Owner has determined that the Contractor shall possess a valid Class A or Class C-8 Contractor License at the time that the contract is awarded. Failure to possess the specified license shall render the bid as non-responsive and shall act as a bar to award of the contract to any bidder not possessing said license at the time of award.

NOTIFICATION OF UTILITIES. Before commencing any work under this contract, the Contractor shall notify the Underground Service Alert (USA) at 800 227-2600 a minimum of 72 hours prior to excavation activities.

LICENSE, FEES AND PERMITS. Plan check fees required for operations under this contract will be paid by the City.

CONSTRUCTION HOURS. See 5-1.08

MEASUREMENT AND PAYMENT. All work performed under this contract shall be paid for at the unit prices detailed in the bid proposal unless specifically noted otherwise or modified in the various sections of work under the City special provisions. Payment shall include all costs associated with labor, equipment, *materials* and expenses required to complete the work, and no additional payment will be made therefor.

**7-4.01     NOT USED**

**7-5.01     MOBILIZATION**

GENERAL. This work shall conform to the requirements of Section 11, "Mobilization" of the State of California Standard Specifications and shall consist of preparatory work and operation, including, but not limited to, those necessary for the movement of personnel, equipment supplies, and incidentals to the project site for the establishment of facilities necessary for work on the project and for all other work and operations which must be performed or costs incurred prior to beginning work on the various contract items on the project site.

A Sausalito Buisness License shall be secured prior to mobilization. Information about Business Licenses may be found on the City of Sausalito's website: <http://www.ci.sausalito.ca.us/Index.aspx?page=127>.

SCOPE OF WORK. Mobilization shall consist of all work in mobilizing the Contractor's equipment, furnishing required submittals and installing temporary fencing.

STAGING AREA. The Contractor shall obtain permission from the Engineer to use any portion of the public right-of-way for a staging area.

**PAYMENT**

The lump sum price paid for "Mobilization" shall include full compensation for furnishing all personnel, equipment, and supplies and no additional payment will be made therefor. This amount shall not exceed five percent (5%) of the total bid price for the Work.

**7-6.01     DEMOLITION**

GENERAL:

- A. Specifications for the demolition, removal, and legal disposal of materials within the scope of this project, as shown on the design plans and described in the project specifications.
- B. Extent of demolition work shall be as shown or noted on the design plans, as required to meet Standard Plan design requirements, or described in these project specifications.
- C. Restoration of existing structures and facilities to remain in place which are damaged by demolition and removal operations shall be replaced or repaired by the Contractor at no cost to the City.

PERMITS:

- A. Obtain all special permits and licenses and give all notices required for performance and completion of the demolition and removal work, hauling, and disposal of debris.
- B. Submit copies of demolition, hauling, and debris disposal permits and notices for record purposes. Include description of proposed haul routes.

SITE CONDITIONS:

- A. Erect and maintain temporary bracing, shoring, lights, barricades, signs, and other measures as necessary to protect the public, workers, and adjoining property from damage from demolition work, all in accordance with applicable codes and regulations.

- B. Open depressions and excavations occurring as part of this work shall be barricaded and posted with warning lights when accessible through adjacent property or through public access. Open depressions and excavations shall be filled at the end of each working day to the satisfaction of the Engineer.
- C. Protect utilities, pavements, and facilities from damage caused by settlement, lateral movement, undermining, washout, and other hazards created by demolition operations.
- D. Protection of Utilities: Protect active sewer, water, gas, electric, and other utilities; and drainage and irrigation lines indicated or, when not indicated, found or otherwise made known to the Contractor before or during demolition work.
- E. Maintain existing utilities and protect from damage as necessary to satisfy the requirements of jurisdictional utility companies and related codes and regulations.
- F. Make arrangements with affected utility companies and City to provide the information and services necessary to coordinate and complete the Work.
- G. Do not disconnect or shut down any part of the existing utilities and services, except by permission of authorities having jurisdiction. Submit schedule of estimated shut-down time in order to obtain such permission, and notify all interested parties, neighbors, utilities, and municipal and county authorities, as required.
- H. Utilities to be removed shall not be removed until shut-down time can be kept to a minimum. Do not remove an existing utility line or service until the replacement line, crossover, or capping is ready to be performed.
- I. Notify the Engineer and utility owners 72 hours before performing any excavation work. Notify affected utilities by calling Underground Service Alert (USA) at 1-800-227-2600. Contact utility owners not covered by USA, by calling the affected utility owners directly.
- J. Protect active underground utilities from damage. If underground utilities are damaged in any way, notify the Engineer and affected utilities immediately for corrective action.
- K. Noise and Dust Abatement: Comply with requirements specified in Section 01 50 00 - Temporary Facilities and Controls. In addition, provide continuous noise and dust abatement as required to prevent disturbance and nuisance to the public and workers and to the occupants of adjacent premises and surrounding areas. Dampen or cover areas affected by demolition operations as necessary to prevent dust nuisance. All sawcutting of concrete or asphalt pavements shall include immediate dust control by water.
- L. The Contract Drawings and related documents may not represent all surface conditions at the site and adjoining areas. The known surface conditions are as indicated, and shall be compared with actual conditions before commencement of work.
- M. Existing utilities and drainage systems below grade are located from surface facilities such as manholes, valve boxes, area drains, and other such surface fixtures.
- N. If existing active services encountered are not indicated or otherwise made known to the Contractor and interfere with the permanent facilities under construction, notify the Engineer in writing, requesting instructions on their disposition. Take immediate steps to ensure that the service provided is not interrupted, and do not proceed with the work until written instructions are received from the Engineer.
- O. Existing roadside signs to be relocated as identified in the design plans or as directed by the Engineer shall be protected from damage as necessary and installed to the satisfaction of the Engineer per applicable codes and regulations.

MATERIALS, EQUIPMENT, AND FACILITIES:

- A. Furnish all materials, tools, equipment, devices, appurtenances, facilities, and services as required for performing the demolition and removal work.

DEMOLITION

- A. Demolish Portland cement concrete and asphaltic concrete in small sections. Perform demolition with small tools as much as possible. Blasting will not be permitted.
- B. Backfill and compact depressions caused by excavations, demolition, and removal in accordance with the requirements of the contract documents.

RESTORATION OF EXISTING STRUCTURES AND FACILITIES:

- A. All damage to existing structures and facilities, including utilities, which are to remain in place, shall be repaired to a condition equal to that existing prior to the beginning of demolition and removal operations. The cost of repairing existing structures and facilities damaged by the Contractor's operations shall be at the Contractor's expense.

CLEANUP:

- A. Provide a clean and orderly site.

Existing curb, gutter, and sidewalk, asphalt pathways, concrete pathways, and concrete driveways, where specified on the plans shall be removed and disposed of in accordance with the provisions of Section 7-1.13 of the Standard Specifications, existing concrete removal shall conform to Section 15-3, "Removing Concrete," of the Standard Specifications.

Concrete curb, gutter, sidewalks and driveways shall be sawcut and removed within existing joints as necessary. All sawcutting slurry shall be vacuumed and removed from the site concurrent with the sawcutting operation. Asphalt Concrete shall be sawcut.

Demolition shall also include the removal and disposal of all items as shown on the plans conflicting with the work; removal and disposal of signs and posts to be permanently removed from project limits; sawcutting; removal and disposal of asphalt concrete; removal and disposal of miscellaneous concrete, including curb and gutter, sidewalks and miscellaneous concrete; and removal and disposal of bricks and miscellaneous planter material, or work as directed by the Engineer.

**PAYMENT**

Full compensation for furnishing all labor, materials and equipment necessary to perform the removal and disposal of materials, including but not limited to Portland cement concrete curb ramps, sidewalk, curbs, curb and gutter, asphaltic concrete and other materials and structures shown or noted on the Plans shall be included in the lump sum price paid for under "Demolition". No additional compensation will be allowed.

**7-7.01 TRAFFIC CONTROL**

GENERAL. Contractor shall provide traffic control within the construction area in accordance with these City special provisions.

The Contractor shall refer to the current CALIFORNIA MANUAL ON UNIFORM TRAFFIC CONTROL DEVICES PART 6 TEMPORARY TRAFFIC CONTROL and other relevant traffic control guidance documents, issued by the California Department of Transportation, and shall furnish, maintain and remove temporary traffic stripes and legend, traffic control signs, lights, flares, barricades and other warning devices, and furnish competent flag persons and guards at his expense when necessary for public safety.

Personal vehicles of the Contractor's employees shall not be parked on the traveled way at any time including any section closed to public traffic. When entering or leaving roadways carrying public traffic, the Contractor's equipment, whether empty or loaded, shall in all cases yield to public traffic.

The use of fluorescent traffic cones to direct traffic away from excavations shall be considered as lane closure. No excavation shall remain open longer than is necessary to perform the work as determined by the Engineer. Construction of street improvements and structures, and conduit installation shall follow immediately after excavation and shall be performed in a continuous operation during each working day. All excess and unsuitable material resulting from the Contractor's operations shall be removed as it develops and before the end of each day.

No material or equipment shall be stored where it will interfere with the free and safe passage of the public. At the end of each day's work and at other times when construction operations are suspended for any reason, the Contractor shall remove all equipment and other obstructions from that portion of the roadway open for public use. During the pre-construction conference Contractor shall present the traffic control plan. In this plan Contractor shows the routes that will be used to receive construction material or dispose of debris and hazardous material.

Construction is within the City-owned right of way and provisions shall be made for the safe passage of vehicular, bicycle and pedestrian traffic around the area of the work at all the times. Every effort shall be made by the Contractor to permit access into private driveways and building entrances. Local and emergency traffic shall be given full access to their destination through the project area.

The Contractor shall be responsible for keeping the local Police and Fire Departments informed of any obstructions to either public or private roads or properties caused by his \her operation. The Contractor shall Post " No Parking, Tow – Away" signs on barricades along the portions of streets affected by work at least 72 hours prior to start of work. Should the work not occur on the specified date, a new notice shall be posted by the Contractor.

Traffic lane closures shall be as approved by the City Engineer, and under no circumstances shall the Contractor close off a street for any period of time without prior approval from the City Engineer. The maximum traffic delay duration is 10 minutes for daytime work.

When construction operations are not actively in progress, not less than two such lanes shall be opened to public traffic. The full width on the traveled way shall be opened for use by public traffic on Saturdays, Sundays, designated City holidays, after 3:00 p.m. on Fridays, the day preceding designated legal holidays, and when construction operations are not actively in progress.

The Contractor shall furnish, install, maintain and remove at his/her expense all barricades, signs, lights, or other devices necessary to adequately warn any obstruction to the vehicular pedestrian travel way. Flagmen shall be provided as necessary for the safety of pedestrians and vehicular traffic, and to provide access to the properties adjacent to the work.

At the end of each work day, the Contractor shall remove all the components of traffic control system, except portable delineators placed along a pavement elevation differential, or as required by the Engineer.

Before obstructing any private driveway entrance or City street with equipment or other barriers, for any prolonged period of time, the Contractor shall notify the known users of the respective thoroughfare(s) involved at least (5) working days before work begins and shall provide access for pedestrians to and from the street. If work is interrupted, Contractor shall re-notify private owners and City Engineer (5) days prior to the resumption of work.

All costs involved in this work, including traffic flagging costs, shall be included in the lump sum price paid for "Traffic Control" and no additional compensation will be allowed.

The fact that rain or other causes may force suspension or delay of the work shall not relieve the Contractor of his/her responsibility for maintaining traffic around the project and providing access as specified herein. The Contractor shall at all times keep on the job such materials and equipment as may be necessary to keep streets and driveways within the project area open to traffic and in good repair.

Should the Contractor fail, in the opinion of the Engineer, to provide all materials, work force and equipment necessary to maintain traffic around the work area as set forth herein, the City may take necessary steps to suspend the contract. The City may then, upon such suspension, cause such work to be done as may be necessary to maintain traffic, and charge same against the Contractor Sureties.

The provisions in this section may be modified or altered if, in the opinion of the Engineer, public traffic will be better served and work expedited. Said modifications or alteration shall not be adopted until approved in writing by the Engineer.

### **PAYMENT**

The contract lump sum price paid for traffic control shall include full compensation for furnishing all labor (including flagman cost), materials, (including Construction area and No Parking signs), tools equipment, barricades and incidentals, and for doing all the work involved in installing, maintaining, relocating, and removing the components of traffic control system throughout the life of the project (including Saturdays, Sundays, and holidays), as specified in the State Standard Specifications, and these city special provisions and as directed by the Engineer, and no additional compensation will be allowed.

### **7-8.01 CONSTRUCTION STAKING**

This work consists of furnishing and setting construction stakes and marks by the Contractor to establish the lines and grades required for the completion of the improvements as shown on the plans, and as specified in these Special Provisions.

Construction staking shall be performed as necessary to control the work. Construction stakes and marks shall be furnished and set by the Contractor with accuracy adequate to assure that the completed work conforms to the lines, grades, and notes on the plans.

Prior to the commencement of demolition, the contractor shall field verify and mark limits of removal to ensure finish slopes and grades are compliant with the Americans with Disabilities Act, the California Building Code and Title 24 of the California Code of Regulations. Before work commences, the contractor shall review the location of the proposed work with the engineer and make any changes as deemed necessary to the line and grade or construction staking, at no extra charge.

At least five (5) working days before surveying and constructing any excavation, the Contractor shall mark out the location of each proposed curb ramp.

#### **Horizontal & Vertical Control:**

Any plan error or discrepancy shall be brought to the Engineer's attention immediately. Before work commences, the Contractor shall review the location of the proposed work with the Engineer and make any changes as deemed necessary to the line and grade or construction staking, at no extra charge.

All computations necessary to establish the exact position of the work shall be made by the Contractor.

### **PAYMENT**

Full compensation for all labor, materials, tools, equipment and doing all work involved as described for Construction Staking shall be considered included in the contract prices paid for various other items of work and no additional compensation will be allowed therefor.

### **7-9.01 MINOR CONCRETE (CURB AND GUTTER, CURB RAMPS, SIDEWALKS)**

Minor Concrete (Minor Concrete Structures) shall conform to the provisions of Sections 51-1.02 and 90-10, the Amendments to May 2010 Standard Specifications, Section 73, "Concrete Curbs and Sidewalks," Section 52, "Reinforcement," and applicable portions of the Uniform Construction Standards (May 2008) approved and adopted by the County of Marin and these Special Provisions. Removing existing concrete shall conform to Section 15-3, "Removing Concrete" of the Standard Specifications. Amendments to May 2010 Standard Specifications can be downloaded from the Caltrans web site: [http://www.dot.ca.gov/hq/esc/oe/specifications/SSPs/2006-SSPs/Sec\\_01-03/](http://www.dot.ca.gov/hq/esc/oe/specifications/SSPs/2006-SSPs/Sec_01-03/)

Minor concrete structures shall include curbs and gutters, standard curb, ramps, sidewalks, curb ramps (including retaining curbs), storm drain inlet modifications and miscellaneous concrete work as shown or noted on the plans. Where all new concrete sidewalk, curb and gutter, ADA curb ramp areas and miscellaneous new concrete conforms to existing concrete, contractor **shall embed #4 reinforcing bar into the existing concrete 24" on center by means of drilling and inserting the reinforcing bar. These bars shall be 12" in length, embedded six inches in the existing concrete with the remainder of the bar in the new concrete, or as directed by the City Engineer.** Structure excavation and structure backfill incidental to minor concrete work shall be included in the price paid for minor concrete. Structure excavation and backfill shall comply with Section 19-3 of the Standard Specifications.

Concrete used for curbs and gutters, sidewalks, and curb ramps shall be Class "B" concrete (except where otherwise indicated on the plans), shall contain a minimum of five (5) sacks of Portland Cement per cubic yard and shall have a 28-day compressive strength of at least 2,500 psi. All concrete shall comply with Marin County Uniform Construction Standards Dwg. No. 100 specifications. The aggregate grading shall be the local standard ¾-inch maximum plant mix as approved by the Engineer.

In lieu of the provisions in Section 73-1.04, "Fixed Forms," of the Standard Specifications, surfaced lumber of nominal dimension may be used for forming the back of the curb and gutter and the front face of the gutter, provided the complete curb and gutter are constructed to the full concrete dimensions shown on the plan.

All concrete curb and gutter shall receive a light broom finish.

New concrete curb ramps and sidewalks adjacent to existing concrete shall match the existing as closely as possible, including washing, exposed aggregate, and seeded exposed aggregate. New curb ramps and sidewalks shall not receive a broom finish. See Plan Notes for specific details.

Any damage caused by the Contractor to existing improvements shall be repaired or replaced by the Contractor at no cost to the City.

Concrete shall be cured in accordance with applicable provisions of Section 90-7 of the Standard Specifications. Minor concrete which will be exposed to vehicular traffic shall be protected from bearing the traffic load for a minimum of seven (7) days after placement, unless stated otherwise herein. Traffic plates shall be of sufficient thickness so as not to deflect to or in any way mar the protected concrete.

Curing compound shall be used on all minor concrete surfaces. Application of curing compound shall be made in accordance with Section 90-7.01B, "Curing Compound Method," of the Standard Specifications. The quality and quantity to be used shall be approved by the Engineer. The liquid compound shall contain a coloring matter which does not permanently alter the natural color of the concrete, but which will color sufficiently at the time of application to indicate readily the areas covered. The use of any membrane material which would impart a slippery surface to the concrete will not be permitted. The liquid shall be applied under pressure with a spray nozzle at the rate recommended by the manufacturer, unless otherwise directed by the Engineer, and in such manner as to cover the surface thoroughly. Care shall be exercised to avoid damage to the seal before the expiration of the curing period. Seal damage shall be immediately repaired by the application of additional membrane material over the damaged portion.

#### CURB AND GUTTER AND CURB

Curb and Gutter and Curb (without gutter) shall both comply with County of Marin Uniform Construction Standards, 2008, Drawing #105, but may be modified by the Engineer to fit field conditions. Where new curb and gutter construction conforms to existing curb and gutter, a minimum of three (3) No.4 reinforcing bars, twelve inches in length, shall be embedded into the existing curb and gutter by means of drilling a hole and inserting the reinforcing bar. These bars shall be embedded six inches with the remainder of the bar in the new concrete. Where new curb meets existing curb, Contractor shall install two dowels.

Transverse weakened plane and expansion joints for curb and gutter shall be placed in accordance with Section 73-1.05 of the Standard Specifications, except where otherwise indicated on the plans. When adjacent to new concrete paving, weakened plane joints in the curb shall coincide with the transverse weakened plane joints in the new



concrete paving. Transverse weakened plane joints for new concrete paving shall be placed at 13.5 foot intervals in accordance with Section 40-1.08 of the Standard Specifications.

The edges of the curb and gutter shall be rounded with an edging tool. Weakened plane joints shall be placed in a true straight line which shall be at right angles or radial to the curb line, and at right angles to the surface of the concrete. Weakened planes for curb and gutter shall not exceed one-eighth inch (1/8") in width, and shall be formed by means of an approved weakened plane scoring tool, or a steel bar inserted into the surface to form the weakened plane and removed; or by means of approved strips of forming material which may be left in place. When the forming material is left in place, the top edge shall be slightly below the surface of the concrete. After the surface has been finished, the joint shall be edged with an edging tool having a one-eighth inch (1/8") radius.

New work adjacent to existing shall match the existing as closely as possible. The Contractor shall perform a water test on gutters upon completion of gutter construction. The test must be performed in the presence of the inspector and must demonstrate to the Engineer's satisfaction that positive drainage through the gutter will be achieved with the gutter as constructed. If required by the Engineer, the Contractor shall replace any unsatisfactory curb and gutter and replace said at no additional cost to the City.

**All new curb and gutter shall include a new asphaltic concrete pavement conform of sufficient width to create a smooth transition from gutter to existing asphalt roadway. The estimated quantities include a 24 inch wide removal and replacement of AC pavement (from lip of gutter) to conform new gutter to existing AC roadway. If additional or less AC removal and replacement is approved by the City, payment shall be adjusted at unit cost. New asphalt concrete roadway shall match existing thickness, but shall not be less than 6 inches.**

#### CURB RAMPS

Curb ramps shall comply with Caltrans Standard Plans RSP A88A, RSP A88B, A90 (2014) and details shown or noted on the plans, but may be modified by the Engineer to fit field conditions. Amendments to May 2010 Standard Plans can be downloaded from the Caltrans web site: [http://www.dot.ca.gov/hq/esc/oe/project\\_plans/HTM/2006-updates.htm](http://www.dot.ca.gov/hq/esc/oe/project_plans/HTM/2006-updates.htm).

An accessible pedestrian path-of-travel shall be maintained at all times by the Contractor during minor concrete work. Any exception must be approved in advance by the Engineer. Where necessary, temporary path of travel improvements may include but are not limited to, temporary curb ramps, protected walkways when pedestrians are directed into the vehicle travel way and signage to redirect pedestrian traffic. All temporary measures shall be compliant with state and federal ADA requirements. Pedestrian path of travel detours shall not create sight distance constraints for motorists. The Contractor is responsible for maintenance of all temporary pedestrian path improvements. **The Contractor shall submit a temporary pedestrian control plan to the Engineer prior to demolition and subsequent construction of curb ramps. The temporary pedestrian control plan shall clearly indicate temporary pedestrian path of travel at all times. The demolition shall commence only upon approval of the plan by the Engineer. Contractor shall allow (5) working days for review of the plan. No additional working days will be allowed for review of the plan. Once the temporary pedestrian control plan is approved by the Engineer, modifications to the plan shall only be allowed with written approval from the Engineer.**

Curb ramps shall include all construction details of each respective type of ramp to be installed as specified in the Standard Plans, as shown or noted on the project Plans,, including retaining curbs, Detectable Warning Tiles, adjustment of utility lids and boxes, removal and replacement of street signs and other structures. Forms and finished slopes on new curb ramps shall be inspected by the City. All curb ramp forms shall be checked by the City prior to pouring concrete and Contractor shall be responsible for notifying the Engineer and coordinating this inspection. Contractor shall be solely responsible for new concrete slopes compliance with Standard Drawings and project Plans and Specifications. Construction details include the installation of joints, grooves, retaining curb, if necessary, adjustment of utility boxes to new grade, relocation of street/traffic signs, conforming work with existing private improvements and adjacent concrete finishes, and any modifications to fit field conditions as directed by the Engineer.

Detectable Warning Surface shall be Armor-Tile ADA-C Detectable/Tactile Warning Surface Tile (panel dimensions as shown on project plans), yellow color no. 33538 or brick red color no. 22144 of FED-STD-595, as shown on the plans or directed by the City. Information on Armor-Tile truncated domes can be downloaded from <http://www.armor-tile.com>.

## SIDEWALKS

Sidewalks shall be Class "B" concrete and comply with the Marin County Uniform Construction Standard Dwg. numbers 100 and 105 and per detail shown on the plans, but may be modified by the Engineer to fit field conditions.

## MEASUREMENT

Minor Concrete - Concrete Curb and Gutter and Curb without gutter shall be measured by the linear foot in place.

Minor Concrete - Curb Ramps, landings, and transitions to existing sidewalks shall be measured by the square foot in place. Unit price shall include a ramp, transition areas, and 12" wide border with grooves. Compensation for retaining curb, adjustment of various utility lids and boxes, removal and replacement of street signs, and matching adjacent concrete finishes shall be considered as included in the respective unit prices paid for curb ramps and sidewalk and no additional payment will be made.

## PAYMENT

The contract price paid for **Curb and Gutter and Curb Ramps and adjacent Sidewalks and Landings** shall include full compensation for furnishing all labor, materials (including aggregate base), tools, coordinating with utility companies and working around their facilities, equipment, and incidentals necessary to complete the work (including structure excavation and backfill, furnishing and placing and removing formwork and falsework, reinforcing steel, curing, and water testing) as shown on the plans and specified herein, for completing in place all the work involved in constructing these items, as shown on the plans and specified in the Standard Specifications and these Special Provisions, or as directed by the Engineer.

The linear foot price paid for **Curb and Gutter and Curb without gutter** shall include full compensation for furnishing all labor, materials, and equipment necessary to complete the work (including demolition, saw-cutting and forming) as shown on the Plans and specified or referenced herein. No adjustment in the contract unit price for Curb and Gutter shall be made for increases or decreases of more than 25 percent of the quantities set forth in the Schedule of Bid Prices. Sections 4-1.03B(1) and 4-1.03B(2) of the Standard Specifications shall not apply.

The square foot price paid for concrete **Curb Ramps and adjacent Sidewalks and Landings** shall include full compensation for furnishing all labor, materials, and equipment necessary to complete the work (including saw-cutting, forming, and dowels) as shown on the Plans and specified herein. No adjustment in the contract unit price for Curb and Gutter shall be made for increases or decreases of more than 25 percent of the quantities set forth in the Schedule of Bid Prices. Sections 4-1.03B(1) and 4-1.03B(2) of the Standard Specifications shall not apply.

### **7-10.01 ASPHALT CONCRETE**

Asphaltic concrete shown or noted on the Plans or these Specifications to be removed shall be sawcut and removed. Existing aggregate base shall be compacted to 95% relative compaction prior to placement of new asphalt concrete.

Asphalt concrete shall conform to the provisions of Section 39 of the Standard Specifications and these Special Provisions.

Asphalt concrete shall be Type "A", 1/2 inch Maximum, Medium Gradation, conforming to the requirements of Section 39-2 of the Standard Specifications.

Paint binder shall be RS-1 and shall be applied on vertical surfaces of existing pavements immediately prior to the placement of new asphaltic concrete.

All mixtures shall be spread at a temperature of not less than 260 degrees F., and not greater than 300 degrees F.

Initial rolling or compaction shall be performed immediately after placement.

No asphalt concrete is to be placed when the atmospheric temperature is below 50 degrees F.

The Contractor shall furnish and use tarpaulins to cover asphaltic concrete during transport from the mixing plant to the project site.

Spreading, shoveling or raking asphalt concrete shall not leave irregular or segregated areas. The Contractor shall supply an appropriate number of qualified, experienced rakers and shovelers.

Asphalt spilled on to any new or old paving shall be removed along with loose asphalt concrete.

The Contractor shall furnish equipment capable of producing the required compaction. Vibratory rollers shall be double steel drum, having adjustable frequency and amplitude settings directly available to the operator during the operation. The roller shall be equipped with self-reversing eccentrics. The vibratory mode shall automatically shut off when machine direction is changed.

**Asphalt concrete surfacing shall be placed in lifts no greater than 3 inches in thickness (compacted). Total thickness of surfacing shall match existing but shall be 6 inches minimum. All new curb and gutter shall include a new asphaltic concrete pavement conform of sufficient width to create a smooth transition from gutter to existing asphalt roadway. The estimated quantities include a 24 inch wide removal and replacement of AC pavement (from lip of gutter) to conform new gutter to existing AC roadway. If additional or less AC removal and replacement is approved by the City, payment shall be adjusted at unit cost.**

**Note: when AC pavement is removed adjacent to new curb and gutter, Contractor shall install compacted backfill and pave with temporary cold asphalt, such as EZ Street by Syar industries, or equivalent subject to City approval, within 24 hours of the concrete pour. The cold asphalt shall be a minimum of 2 inches thick, properly graded and compacted to provide a smooth transition from new gutter to existing AC pavement. Permanent AC pavement shall be installed as soon as practicable thereafter.**

Asphalt concrete shall be compacted to a minimum 93 percent of Maximum Theoretical Density as determined by American Society of Testing Materials (ASTM) D-2041. New asphaltic concrete with a relative compaction of less than 90% shall be removed and replaced by the Contractor at no additional cost to the City.

The surface, when completed, shall be smooth, dense, well-bonded, and of uniform texture and appearance. The compacted surface course of asphalt concrete shall be free from ruts, humps, depressions or irregularities. When a straight-edge 12 feet long is laid on the finished surface and parallel with the center line of the road or driveway, the surface shall not vary more than 0.02 foot from the lower edge of the straight-edge. The transverse slope of the finished surface shall be uniform to a degree such that no depressions greater than 0.02 foot are present when tested with a straight-edge 12 feet long laid in a direction transverse to the center line and extending from edge to edge of a 10 foot pass.

Any ridges, indentations or other objectionable marks left in the surface of the asphalt concrete shall be eliminated by rolling or other means. The use of any equipment that leaves ridges, indentations or other objectionable marks in the asphalt concrete shall be discontinued.

#### **PAYMENT**

The square foot price for asphaltic concrete shall include all labor, materials, tools, and equipment to complete the work, including sawcutting and demolition of existing asphaltic concrete.

#### **7-11.01 BRICK PAVING**

For work to replace the existing curb ramp with a circular brick pattern located on Bridgeway Blvd. at Caledonia Street (BW 22-08), contractor shall maintain the existing circular brick pattern through the new curb ramp and adjacent concrete by "blocking out" the brick pattern in the new curb ramp concrete pour and then setting the new bricks in a 3/8 inch to 1 inch thick mortar bed and installing mortar between the bricks. Type M mortar shall conform to ASTM C270. Bricks shall be placed to match existing brick pattern and joint spacing. All joints shall be filled completely with mortar that shall be compressed.

Finish surface of brick pattern shall be smooth, with vertical offsets between bricks or between bricks and adjacent concrete not to exceed 1/4 inch.

### MEASUREMENT AND PAYMENT

The lump sum contract price paid for maintaining the circular brick pattern in the curb ramp on Bridgeway Blvd. at Caledonia Street shall include full compensation for furnishing all labor, materials and equipment necessary to complete the work as shown on the Plans and specified herein. No additional compensation shall be allowed.

#### **7-12.01 CLASS 2 AGGREGATE BASE**

Class 2 Aggregate Base (Class 2 AB) shall conform to Section 26 of the Standard Specifications for  $\frac{3}{4}$ " Maximum Class 2 AB.

Spreading and compacting of a minimum 4 inches of Class 2 AB sidewalk, and curb and gutter subgrade material shall be performed by methods that will produce a uniform base, firmly compacted, and free from pockets of coarse or fine material. Subgrade material shall be Class 2 AB in accordance with Section 26-1.02A of the Standard Specifications for  $\frac{3}{4}$ " maximum gradation (except where otherwise indicated on the plans) and compaction shall be moisture conditioned (if necessary) to above optimum moisture content and compacted to at least 95 percent relative compaction. The subgrade should not be allowed to dry out prior to pavement construction.

### PAYMENT

Full compensation for all labor, materials, tools, equipment and doing all work involved as described for Class 2 Aggregate Base shall be considered included in the contract prices paid for various other items of work and no additional compensation will be allowed therefor.

#### **7-13.01 ADJUST FRAMES AND COVERS TO GRADE**

Frames and covers of existing utility boxes, monuments or other facilities shall be adjusted to grade in accordance with the provisions in Section 15-2.05A, "Frames, Covers, Grates, and Manholes," of the Standard Specifications or as noted on the Plans.

### PAYMENT

Payment for adjusting all utility frames and covers shall be included in the unit cost of new ADA curb ramp, sidewalk, and adjacent concrete.

#### **7-14.01 NOT USED**

#### **7-15.01 DETECTABLE WARNING SURFACE TILE**

Detectable Warning Surface Tiles shall be Armor-Tile ADA-C Detectable/Tactile Warning Surface Tile, Yellow color no. 33538 or Brick Red color no. 22144 of FED-STD-595, (as shown on Plans, unless otherwise noted on Plans). Information on Armor-Tile truncated domes can be downloaded from <http://www.armor-tile.com>.

### PAYMENT

The square foot price paid for Detectable Warning Surface Tiles shall include all materials, labor, tools, equipment and incidentals required to install the Tiles as shown on the Standard Plans, the Project Plans and notes, and these Specifications.

#### **7-16.01 CATCH BASIN FRAMES AND GRATES**

New catch basin frames and grates shall be fabricated to comply with Marin County Uniform Construction Standards Type C catch basin frames and grates (Dwg. No. 220) and shall be fabricated and installed consistent with Note 5 of that drawing which states that  $\frac{1}{2}$  inch grate openings shall be perpendicular to the walking direction, and shall be otherwise compliant with ADA requirements.

### PAYMENT

Full compensation for all labor, materials, tools, equipment and doing all work involved in fabrication and installation of Type C catch basin frames and grates shall be included in the unit cost of this item and no additional compensation will be allowed therefor.

**SECTION 8. (BLANK)**

**SECTION 9. (BLANK)**



**SAMPLE AGREEMENT  
INCLUDED FOR INFORMATION PURPOSES ONLY**

**CITY OF SAUSALITO  
PUBLIC WORKS CONTRACT**

**ACCESSIBILITY IMPROVEMENT PROJECT 2015—BRIDGEWAY SOUTH**

This Contract, made and entered into this \_\_\_\_\_ day of \_\_\_\_\_, 2015, by and between the City of Sausalito, Marin County, California (hereinafter "City") and \_\_\_\_\_, (hereinafter "Contractor").

In consideration of the mutual promises contained herein, and based upon the provisions set forth above, the parties agree as follows:

**Section 1. Contract Documents**

This Contract consists of and includes this four page Agreement, the Notice to Bidders, the Instruction to Bidders, the Special Provisions, the Plans prepared by the City of Sausalito, the City of Sausalito General Provisions, the Technical Provisions (section 20 through 80) of the "Standard Specifications for Public Works Construction, All Cities and County of Marin," the accepted proposal of Contractor, all addenda referred to in Exhibit \_ of this Agreement, the Performance Bond, Payment Bond, all insurance and security required and the non collusion affidavit required by §7106 of the Public Contracts Code. These documents together form the Contract between City and Contractor, and all are incorporated as fully a part of the Contract as if attached to this Agreement or repeated herein. Throughout the remainder of this Agreement, the "Contract Documents" shall refer to each and every document referred to in this section.

**Section 2. The Work**

Contractor shall perform everything required to be performed and in the manner required to be performed, in the Contract Documents for "ACCESSIBILITY IMPROVEMENT PROJECT 2015—BRIDGEWAY SOUTH". The duties of Contractor required under the Contract and this Section 2 of the Agreement are referred to throughout the remainder of this Contract as "the Work."

**Section 3. Work Schedule**

Contractor shall not commence the Work until after receipt of Notice to Proceed issued by the City Engineer, and Contractor shall thereafter commence the Work within five (5) calendar days of receipt of such Notice. The Work shall be completed within thirty-five (35) consecutive working days after the start date noted on the Notice to Proceed.

**Section 4. Contract Price**

City shall pay Contractor for the performance of the Work as the total contract price the total amount of \_\_\_\_\_, which amount is as provided in the Approved Bid. Payment of such amount is subject to any deductions of adjustments provided for in the Contract Documents or as may be provided for by any approved Change Order.

**Section 5. Amendments**

Amendments to the Contract including any Change Order shall be only by written agreement, signed by both parties. No Amendment to this Contract shall be effective until approved by the City Engineer.

**Section 6. Independent Contractor - Subcontractors**

It is specifically understood and agreed that in the making and performance of this Contract, Contractor is an

independent contractor and is not and shall not be construed to be an employee, agent or servant of City. Contractor shall be entitled to employ as its subcontractors only those individuals or firms described in its Bid Proposal, which subcontractors shall be required by Contractor to be subject to any terms and conditions of this Contract which pertains to them.

**Section 7. Contractor's Responsibility**

It is understood and agreed that Contractor and any subcontractor has the professional skills and licenses necessary to perform the Work, and that City relies upon the professional skills of the Contractor and any subcontractor to do and perform the Work in a skillful and professional manner in accordance with the standards of the profession. Contractor thus agrees to so perform the Work, and to require the same of any subcontractor.

Acceptance by City of the Work, or any of it, does not operate as a release of the Contractor from such professional responsibility. It is further understood and agreed that Contractor has reviewed in detail the scope of the work to be performed under this Contract and agrees that in his professional judgment, the Work can and shall be completed for a fee within the amounts set forth in Section 4 of this Contract.

Contractor agrees to do the Work in accordance with the terms of this Contract and to be bound by the conditions of this Agreement, including all Contract Conditions set out in the documents enumerated in section 1, above.

**Section 8. Hold Harmless, Indemnification and Insurance Requirements**

A. Indemnification and Hold Harmless.

Contractor shall indemnify, defend and save City, its officers, officials, employees and agents harmless from and against any and all liability, claims, suits, actions, damages and/or causes of action of any kind arising out of any bodily injury, personal injury, property damage or in violation of any federal, state or municipal law or ordinance or other cause in connection with the activities of Contractor, its employees, agents, subcontractors or on account of the performance or character of the Work or otherwise related to its performance of this Contract. Approval of any insurance coverage does not, in any way, relieve Contractor of liability under this Indemnification and hold harmless clause.

B. Insurance Requirements, General

Contractor shall promptly obtain, at his own expense, all the insurance required by the Special Provisions and shall submit coverage verification review and approval by City. The notice to proceed with the Work will not be issued, and Contractor shall not commence work, until such insurance has been approved by City. Contractor shall not allow any Subcontractors to commence work on his subcontract until all similar insurance required of the Subcontractor has been obtained and verified. All required insurance shall remain in full force and effect at all times during the prosecution of the Work and until the final completion and acceptance thereof and in compliance with the further terms of the Contract. Notice to proceed does not relieve Contractor of the duty to obtain such insurance as required by the Contract. Each insurance policy shall not be suspended, voided, canceled, reduced in coverage or in limits except after thirty (30) days prior written notice by certified mail, return receipt request, has been given to the City. Any failure to comply with reporting provisions of the policies shall not affect coverage provided to the City, its officers, officials, employees or volunteers.

**Section 9. Nondiscrimination**

There shall be no discrimination against any employee who is employed in the Work, or against any applicant for such employment because of race, religion, color, sex or national origin. This provision shall include, but not be limited to, the following: employment, upgrading, demotion, or transfer, recruitment or recruitment advertising, layoff or termination; rates of pay or other forms of compensation; and selection for training, including apprenticeship.



**Section 10. City Personnel Conflict of Interest**

No officers, member, or employee of City and no member of the governing body of City who exercises any functions or responsibilities in the review, approval of the undertaking or carrying out of the Work, shall participate in any decision relating to this Contract which affects his personal interest or the interest of any corporation, partnership, or association in which he is, directly or indirectly interested; nor shall any such officer, member or employee of City have any interest, direct or indirect, in this Contract or the proceeds thereof.

**Section 11. Contractor Conflict of Interest**

Contractor covenants that he presently has no interest and shall not acquire any interest, direct or indirect, which would conflict in any manner or degree with the performance of the Work. Contractor further covenants that in the performance of this Contract, no persons having any such interest shall be employed.

**Section 12. Assignment**

Contractor shall not assign any interest in this Contract, and shall not transfer any interest in the same (whether by assignment or notation) without the prior written consent of City.

**Section 13. Ownership of Documents**

Contractor agrees that all designs, drawings, specifications, and other technical data produced in the performance of this Contract including any and all shop drawings shall at the request of City and upon completion or termination of the Contract become the sole property of the City including all rights therein of whatever kind and whether arising from common or civil law or equity, and without requirement of additional compensation. Contractor agrees that City shall have access at all reasonable times to inspect and make copies of all notes, designs, drawings, specifications and other technical data pertaining to the Work.

All drawings and engineering documents shall be subject to the approval of and if requested by the City Engineer shall be prepared for the signature of the City Engineer.

**Section 14. Enforcement of Contract - Attorney Fees**

In the event it shall be necessary for either party to institute court action to enforce any of the terms of this Contract, the prevailing party in such litigation shall be entitled to recover reasonable attorney's fees.

**Section 15. Miscellaneous Provisions**

- A. Time is of the essence in the performance of this Contract.
- B. This Contract shall extend to, be binding upon and inure to the benefit of any executor, administrator, successor, heir and assign of the parties hereto.

**In Witness Whereof**, City and Contractor have executed this Contract as of the date first written above.

City of Sausalito:

Contractor:

\_\_\_\_\_  
City Manager

\_\_\_\_\_  
Corporate authority of:

Recommended for approval by:

\_\_\_\_\_  
City Engineer

Approved as to form by:

\_\_\_\_\_  
City Attorney

\_\_\_\_\_  
to enter into this  
Contract confirmed by:

\_\_\_\_\_  
Corporate Secretary

**WORKER'S COMPENSATION INSURANCE CERTIFICATE**

The Contractor shall execute the following form as required by the California Labor Code, Sections 1860 and 1861:

I am aware of the provisions of Section 3700 of the Labor Code which require every employer to be insured against liability for worker's compensation or to undertake self-insurance in accordance with the provisions of that code, and I will comply with such provisions before commencing the performance of the work of this Contract.

Date: \_\_\_\_\_

\_\_\_\_\_  
Contractor

By: \_\_\_\_\_  
Signature

\_\_\_\_\_  
Title

Attest: \_\_\_\_\_  
Signature

\_\_\_\_\_  
Title

**PERFORMANCE BOND**

KNOW ALL MEN BY THESE PRESENTS: That

WHEREAS, the City Council of the City of Sausalito, County of Marin, State of California, has awarded to

\_\_\_\_\_  
\_\_\_\_\_  
(hereinafter designated as "Principal")

a contract for **ACCESSIBILITY IMPROVEMENT PROJECT 2015—BRIDGEWAY SOUTH**, and,

WHEREAS, said Principal is required under the terms of said contract to furnish a bond for the faithful performance of said contract,

NOW, THEREFORE, we, the Principal and \_\_\_\_\_ Surety, are held and firmly bound unto the City of Sausalito (hereinafter called "City"), in the penal sum of \_\_\_\_\_ (\$ \_\_\_\_\_) lawful money of the United States, for the payment of which sum well and truly to be made, we bind ourselves, our heirs, executors, administrators, and successors jointly and severally, firmly by these presents.

The condition of this obligation is such that if the above bounded Principal, his or its heirs, executors, administrators, successors or assigns shall in all things stand to and abide by, and well and truly keep and perform the covenants, conditions, and agreements in the said contract and any alteration thereof made as therein provided, on his or their part, to be kept and performed at the time and in the manner therein specified, and in all respects according to their true intent and meaning, and shall indemnify and save according to their true intent and meaning, and shall indemnify and save harmless City, its officers, representatives, agents, and employees, as therein stipulated, then this obligation shall become null and void; otherwise it shall be and remain in full force and effect.

And the said Surety for value received, hereby stipulates and agrees that no change, extension of time, alteration, or addition to the terms of the contract or to the work to be performed thereunder or the specifications accompanying the same shall in any way affect its obligations on this bond, and it does hereby waive notice of any such change, extension of time, alternation, or additions to the terms of the contract or to the work or to the specifications.

In the event suit is brought upon this bond by City and judgment is recovered, Surety shall pay all costs incurred by City in such suit, including a reasonable attorney's fee to be fixed by the court.

IN WITNESS WHEREOF, two identical counterparts of this instrument, each of which shall for all purposes be deemed an original thereof, have been duly executed by Principal and Surety above named on the day of \_\_\_\_\_, 20\_\_\_\_\_.

\_\_\_\_\_(Seal)

\_\_\_\_\_(Seal)

\_\_\_\_\_(Seal)

Principal

\_\_\_\_\_(Seal)

\_\_\_\_\_(Seal)

\_\_\_\_\_(Seal)

Surety

Address

NOTE: Signature of those executing for Surety must be properly acknowledged.

**PAYMENT BOND FOR PUBLIC WORKS**

KNOW ALL MEN BY THESE PRESENTS: That

WHEREAS, the City Council of the City of Sausalito, County of Marin, State of California, and

\_\_\_\_\_ (hereinafter designated as "Principal")

have entered into an agreement for the furnishing of all materials, labor, services, and transportation necessary, convenient, and proper to implement:

**ACCESSIBILITY IMPROVEMENT PROJECT 2015—BRIDGEWAY SOUTH**

which said Agreement dated \_\_\_\_\_, 20\_\_\_\_\_, and all of the Contract Documents attached to or forming a part of said Agreement, are hereby referred to and made a part thereof; and

WHEREAS, said Principal is required by Chapter 5 (commencing at Section 3225) and Chapter 7 (commencing at Section 3247), Title 15, Part 4, Division 3 of the California Civil Code to furnish a bond in connection with said contract;

NOW, THEREFORE, we, the Principal and \_\_\_\_\_ as Surety, are held and firmly bound unto the City of Sausalito (hereinafter called "City"), in the penal sum of \_\_\_\_\_ Dollars(\$\_\_\_\_\_) lawful money of the United States, for the payment of which sum well and truly to be made, we bind ourselves, our heirs, executors, administrators, and successors jointly and severally, firmly by these presents.

THE CONDITION OF THIS OBLIGATION IS SUCH that if the said Principal, his or its subcontractors, heirs, executors, administrators, successors or assigns fail to pay any of the persons named in Section 3181 of the California Civil Code, or amounts due under the Unemployment Insurance code with respect to work or labor performed by any such claimant, the Surety will pay for the same, in an amount not exceeding the sum hereinabove specified, and also, in case suit is brought upon this bond, a reasonable attorney's fee, to be fixed by the court.

This bond shall insure to the benefit of any of the persons named in Section 3181 of the California Civil Code, so as to give a right of action to such persons or their assigns in any suit brought upon this bond.

It is further stipulated and agreed that the Surety on this bond shall not be exonerated or released from the obligation of this bond by any change, extension of time for performance, addition, alteration, or modification in, to, or any contract, plans, specification, or agreement pertaining or relating to any scheme or work of improvement hereinabove described or pertaining to or relating to the furnishing of labor, materials, or equipment therefor, nor by any change or modification of any terms of payment or extension of the time for any payment pertaining or relating to any scheme or work of improvement hereinabove described nor by any rescission or attempted rescission of the contract, agreement, or bond; nor by any conditions precedent or subsequent in the bond attempting to limit the right or recovery of claimants otherwise entitled to recover under any such contract or agreement or under the bond, nor by any fraud practiced by any person other than the claimant seeking to recover on the bond and that this bond be construed most strongly against the Surety and in favor of all persons for whose benefit such bond is given, and under no circumstances bond has been given, by reason of any breach of contract between the owner or Public Entity and original contractor or on the part of any obligee named in such bond, but the sole conditions of recovery shall be that claimant is a person described in Section 3110 or 3112 of the California Civil Code, and has not been paid the full amount of his claim and that Surety does hereby waive notice of any such change, extension of time, addition, alteration, or modification herein mentioned.

IN WITNESS WHEREOF, two identical counterparts of this instrument, each of which shall for all purposes be deemed an original thereof, have been duly executed by Principal and Surety above named on the day of \_\_\_\_\_, 20\_\_\_\_\_.

\_\_\_\_\_(Seal)

\_\_\_\_\_(Seal)

\_\_\_\_\_(Seal)

Principal

\_\_\_\_\_(Seal)

\_\_\_\_\_(Seal)

\_\_\_\_\_(Seal)

Surety

Address

NOTE: Signature of those executing for Surety must be properly acknowledged.

**WARRANTY BOND**

KNOW ALL MEN BY THESE PRESENTS: That

WHEREAS, the City Council of the City of Sausalito, County of Marin, State of California, has awarded to

\_\_\_\_\_ (hereinafter designated as "Principal")

a contract for **ACCESSIBILITY IMPROVEMENT PROJECT 2015—BRIDGEWAY SOUTH**, and,

WHEREAS, said Principal is required under the terms of said contract to furnish a bond for the guarantee of materials used and workmanship performed for a period of one (1) year after the recordation of the "Notice of Completion":

NOW, THEREFORE, we, the Principal and \_\_\_\_\_ as Surety, are held and firmly bound unto the City of Sausalito (hereinafter called "City"), in the penal sum of \_\_\_\_\_ Dollars(\$ \_\_\_\_\_) lawful money of the United States, for the payment of which sum well and truly to be made, we bind ourselves, our heirs, executors, administrators, and successors, jointly and severally, firmly by these presents.

THE CONDITION OF THIS OBLIGATION IS SUCH that if the said Principal, his or its heirs, executors, administrators, successors or assigns shall for a period of one year from the date of recordation of the "Notice of Completion" repair or replace, at the discretion of the City, any and all defective or deficient materials or workmanship used, supplied, or provided by Principal in performance of said contract, and otherwise well and truly keep and perform all the undertakings, terms, covenants, conditions, and agreements as to any all guarantees and warranties required by said contract and any alteration thereof, made as therein provided, all within the time and in the manner therein designated and in all respects according to their true intent and meaning, then this obligation shall become null and void, otherwise it shall be and remain in full force and effect.

FURTHER, the said Surety, for value received, hereby stipulates and agrees that no change, extension of time, alteration or modification of the Contract Documents or of the Work to be performed thereunder, shall in any way affect its obligations on this bond, and it does hereby waive notice of any such change, extension of time alteration or modification of the Contract Documents or of work to be performed thereunder.

IN WITNESS WHEREOF, two (2) identical counterparts of this instrument, each of which shall for all purposes be deemed an original thereof, have been duly executed by the Principal and Surety herein named on the day of \_\_\_\_\_, 20\_\_\_\_.

\_\_\_\_\_(Seal)

\_\_\_\_\_(Seal)

\_\_\_\_\_(Seal)

Principal

\_\_\_\_\_(Seal)

\_\_\_\_\_(Seal)

\_\_\_\_\_(Seal)

Surety



Address

NOTE: Signature of those executing for Surety must be properly acknowledged.

Contract No. \_\_\_\_\_  
Escrow Agreement No. \_\_\_\_\_

**ESCROW AGREEMENT: SUBSTITUTION OF SECURITIES  
PROGRESS PAYMENTS UNDER PUBLIC WORKS CONTRACTS  
(Gov. Code Sec. 4590)**

The parties to this Agreement are: The City of Sausalito, County of Marin ("CITY" herein); and:

\_\_\_\_\_ ("CONTRACTOR" herein), and the  
(name of contractor)

\_\_\_\_\_ ("ESCROW AGENT" herein).  
(name of bank)

**RECITALS**

CITY and CONTRACTOR have entered into a contract for the construction

of \_\_\_\_\_ Contract No. \_\_\_\_\_

This agreement is made pursuant to the authority of Government Code Section 4590; its purpose is to provide for the release to CONTRACTOR of sums which CITY otherwise would be required to withhold from progress payment to CONTRACTOR. This agreement shall be effective as the date of execution by the parties shown on Page 5.

In consideration of their mutual promises the parties hereto agree as follows:

CONTRACTOR agrees:

1. CONTRACTOR shall deliver initially to ESCROW AGENT, in accordance with the provisions of Government Code Section 4590, either or both of the following forms of security in the combined amount of not less than: \$ \_\_\_\_\_. If less than 5% of the total contract amount, CONTRACTOR shall deposit such additional securities as may be required in amounts sufficient to comply with paragraphs 3 and 4 of Section I below.
  - (a) securities listed under Government Code Section 16430;
  - (b) certificates of deposit issued by banks authorized to transact business in California which are members of the Federal Deposit Insurance Corporation, or by savings and loan associations authorized to transact business in California which are members of the Federal Savings and Loan Insurance Corporation. Non-negotiable certificates of deposit shall be payable to the order of \_\_\_\_\_ (name of escrow agent) as Trustee under their Escrow Agreement number \_\_\_\_\_.
2. Any certificates of deposit delivered by CONTRACTOR to ESCROW AGENT, hereunder, shall be accompanied by evidence satisfactory to ESCROW AGENT that the issuing bank or savings and loan company will honor any request for redemption prior to maturity and that payment will be made to ESCROW AGENT without any rights of third parties being permitted to intervene.
3. CONTRACTOR shall maintain on deposit at all times prior to termination of escrow created by this agreement securities as specified in Section I Paragraph (b), above; or a combination of such securities and certificates of deposit having a market value of not less than the amount to be paid to CONTRACTOR under the terms of this agreement.
4. Upon demand of ESCROW AGENT, CONTRACTOR shall deposit with ESCROW AGENT additional

securities as defined in Section I, Paragraphs 1 (a) and 1 (b), above, necessary to maintain said deposit as specified above.

5. CONTRACTOR shall pay all charges made by ESCROW AGENT for services rendered by it as such ESCROW AGENT, including but not limited to service fees and out-of-pocket expenses.
6. CONTRACTOR shall pay any escrow charges made by CITY for escrow services performed by CITY.
7. CONTRACTOR shall deposit with ESCROW AGENT such properly executed documents as, in the opinion of ESCROW AGENT, are necessary to enable ESCROW AGENT to sell deposited securities or to redeem certificates of deposit.
8. CONTRACTOR shall pay any and all costs incurred by CITY or ESCROW AGENT, including but not limited to reasonable attorney's fees, in any legal proceedings in any way arising out of or related to this escrow, including but not limited to legal proceedings challenging the right of CITY or ESCROW AGENT to possess or dispose of said securities.
9. CONTRACTOR agrees that CITY may direct ESCROW AGENT to sell securities or redeem certificates of deposit deposited with ESCROW AGENT under the terms of this CONTRACTOR'S default or failure to perform pursuant to the terms of the construction contract.

CITY agrees:

1. CITY shall pay to ESCROW AGENT, in accordance with established CITY procedures, funds which otherwise would be withheld from progress payments pursuant to the requirements of law and in accordance with the contract documents upon receipt of notice from ESCROW AGENT that the following are on deposit with ESCROW AGENT:
  - (a) securities in the form and amount specified in Section I, Paragraph 1, hereof;
  - (b) documents necessary to enable ESCROW AGENT to sell or redeem the deposited securities.
2. CITY shall be obligated to make such payments only if ESCROW AGENT holds securities deposited under the provisions of Section I, Paragraph 1, having a market value of not less than the total amount otherwise normally withheld from the progress payments to be paid to CONTRACTOR under this agreement.

ESCROW AGENT agrees:

1. ESCROW AGENT shall hold the securities or certificates of deposit in trust for the benefit of CITY until such time as the escrow created hereunder is terminated.
2. ESCROW AGENT shall obtain from CONTRACTOR such documents as in the opinion of ESCROW AGENT are necessary to enable ESCROW AGENT to sell the securities or to redeem the certificates of deposit deposited hereunder.
3. ESCROW AGENT shall review the market value of securities held in said escrow account monthly at the close of business on the first business day of each month.
4. ESCROW AGENT shall pay to CONTRACTOR moneys paid to ESCROW AGENT by CITY, except that in no event will ESCROW AGENT make any payment to CONTRACTOR if such payment will cause the total amount of payments so made to exceed the value of the securities on deposit with ESCROW AGENT as of the date of such payment.
5. ESCROW AGENT shall promptly, upon receipt of written notice from CITY to do so, sell securities or

redeem certificates of deposit and hold proceeds of such sale or redemption for disbursement at the written direction of CITY.

6. ESCROW AGENT shall make no charge to CITY for any services or out-of-pocket expenses incurred in carrying out its duties and obligations under this agreement.
7. ESCROW AGENT shall hold securities as Trustee for CITY as security for payment of money which would otherwise be held by CITY pursuant to the requirements of law, and agrees that the rights of CITY to said securities are superior to any lien (or claim of lien) including but not limited to the right to sell or redeem securities as provided in Section I, Paragraph 8, hereof, which ESCROW AGENT claims or may in the future claim against said deposit.

ALL PARTIES hereto further agree that:

1. CONTRACTOR shall have the right to withdraw or exchange securities from the custody of ESCROW AGENT. Such withdrawal or exchange may be made only if the market value or, in the case of certificates of deposits, face value of securities deposited under the provisions of Section I, Paragraph 1, in the custody of ESCROW AGENT after such withdrawal or exchange equals not less than 100% of total amount paid to CONTRACTOR by ESCROW AGENT under this agreement. ESCROW AGENT shall notify CITY in writing of any such withdrawal or exchange within two business days of such withdrawal or exchange.
2. The total amount of funds to be released to CONTRACTOR pursuant to this escrow agreement, in lieu of being withheld by CITY from progress payments to CONTRACTOR, may be increased during the term of this agreement to 5% of the total contract amount if CONTRACTOR so elects. CONTRACTOR shall deliver to ESCROW AGENT securities as specified in Paragraph 1 having a market value not less than 5% of the total contract amount.
3. This escrow shall terminate and ESCROW AGENT shall return to CONTRACTOR all securities held in its custody promptly upon receipt of written notice from CITY that said securities may be released.
4. CONTRACTOR is the beneficial owner of said securities held by ESCROW AGENT and CONTRACTOR is entitled to receive any and all interest which may be paid thereon.

IN WITNESS WHEREOF, the parties hereto have executed this agreement as of the \_\_\_\_\_ day of \_\_\_\_\_ 20\_\_.

CITY OF SAUSALITO

By: \_\_\_\_\_  
City Engineer

"CONTRACTOR"

\_\_\_\_\_  
(Name of Firm)

By: \_\_\_\_\_

Title: \_\_\_\_\_

ESCROW AGENT

\_\_\_\_\_  
(Name of Firm)

By: \_\_\_\_\_

Title: \_\_\_\_\_

## **APPENDIX A**

### **ARTICLE 1.5**

#### **Resolution of Construction Claims**

[Added Stats 1994 ch 726 § 22 (AB 3069), effective September 21, 1994. Former Article 1.5, also entitled “Resolution of Construction Claims”, consisting of §§ 20104-20104.8, was added Stats 1990 ch 1414 § 2 and repealed, operative January 1, 1994, by the terms of § 20104.8.]

#### Section

20104. Application of article; “Public work”; “Claim”
- 20104.2. Requirements to submit claim; Agency’s response; Dispute by claimant over response; Failure of agency to respond; Inapplicability of article to tort claims
- 20104.4 Procedures to resolve claims
- 20104.6 Payment of portion of claim which is undisputed; Payment of interest on arbitration award or judgment

#### **§ 20104. Application of Article; “Public work”; “Claim”**

- (a)(1) This article applies to all public works claims of three hundred seventy-five thousand dollars (\$375,000) or less which arise between a contractor and a local agency.
- (2) This article shall not apply to any claims resulting from a contract between a contractor and a public agency when the public agency has elected to resolve any disputes pursuant to Article 7.1 (commencing with Section 10240) of Chapter 1 of Part 2.
- (b)(1) “Public work” has the same meaning as in Sections 3100 and 3106 of the Civil Code, except that “public work” does not include any work or improvement contracted for by the state or the regents of the University of California.
- (2) “Claim” means a separate demand by the contractor for (A) a time extension, (B), payment of money or damages arising from work done by, or on behalf of, the contractor pursuant to the contract for a public work and payment of which is not otherwise expressly provided for or the claimant is not otherwise entitled to, or © an amount the payment of which is disputed by the local agency.
- (c) The provisions of this article or a summary thereof shall be set forth in the plans or specifications for any work which may give rise to a claim under this article.
- (d) This article applies only to contracts entered into on or after January 1, 1991.

Added Stats 1994 ch 726 § 22 (AB 3069), effective September 21, 1994.

#### **Former Sections:**

Former § 20104, similar to the present section, was added Stats 1990 ch 1414 § 2 and repealed, operative January 1, 1994 by the terms of § 20104.8.

Former § 20104 was added Stats 1990 ch 321 § 2, effective July 16, 1990, and renumbered to be § 20103.5 by Stat 1990 ch 1414 § 1.

#### **§ 20104.2. Requirements to submit claim; Agency’s response; Dispute by claimant over response; failure of agency to respond; Inapplicability of article to tort claims**

For any claim subject to this article, the following requirements apply:

- (a) The claim shall be in writing and include the documents necessary to substantiate the claim. Claims must be filed on or before the date of final payment. Nothing in this subdivision is intended to extend the time limit or supersede notice requirements otherwise provided by contract for the filing of claims.
- (b)(1) For claims less than fifty thousand dollars (\$50,000), the local agency shall respond in writing to any written claim within 45 days of receipt of the claim, or may request, in writing, within 30 days of receipt of the claim, any additional documentation supporting the claim or relating to defenses to the claim the local agency may have against the claimant.

(2) If additional information is thereafter required, it shall be requested and provided pursuant to this subdivision, upon mutual agreement of the local agency and the claimant.

(3) The local agency's written response to the claim, as further documented, shall be submitted to the claimant within 15 days after receipt of the further documentation or within a period of time no greater than that taken by the claimant in producing the additional information, whichever is greater.

(c)(1) For claims of over fifty thousand dollars (\$50,000) and less than or equal to three hundred seventy-five thousand dollars (\$375,000), the local agency shall respond in writing to all written claims within 60 days of receipt of the claim, any additional documentation supporting the claim or relating to defenses to the claim the local agency may have against the claimant.

(2) If additional information is thereafter required, it shall be requested and provided pursuant to this subdivision, upon mutual agreement of the local agency and the claimant.

(3) The local agency's written response to the claim, as further documented, shall be submitted to the claimant within 30 days after receipt of the further documentation, or within a period of time no greater than that taken by the claimant in producing the additional information or requested documentation, whichever is greater.

(d) If the claimant disputes the local agency's written response, or the local agency fails to respond within the time prescribed, the claimant may so notify the local agency, in writing, either within 15 days of receipt of the local agency's response or within 15 days of the local agency's failure to respond within the time prescribed, respectively, and demand an informal conference to meet and confer for settlement of the issues in dispute. Upon a demand, the local agency shall schedule a meet and confer conference within 30 days for settlement of the dispute.

(e) Following the meet and confer conference, if the claim or any portion remains in dispute, the claimant may file a claim as provided in Chapter 1 (commencing with Section 900) and Chapter 2 (commencing with Section 910) of part 3 of Division 3.6 of Title 1 of the Government Code. For purposes of those provisions, the running of the period of time within which a claim must be filed shall be tolled from the time the claimant submits his or her written claim pursuant to subdivision (a) until the time that the claim is denied as a result of the meet and confer process, including any period of time utilized by the meet and confer process.

(f) This article does not apply to tort claims and nothing in this article is intended nor shall be construed to change the time periods for filing tort claims or actions specified by Chapter 1 (commencing with Section 900) and Chapter 2 (commencing with Section 910) of Part 3 of Division 3.6 of Title 1 of the Government Code

Added Stats 1994 ch 726 § 22 (AB 3069), effective September 21, 1994.

**Former Sections:**

Former § 20104.2, similar to the present section, was added Stats 1990 ch 1414 § 2, amended Stats 1991 ch 1029 § 1, and repealed, operative January 1, 1994, by the terms of § 20104.8.

**§ 20104.4. Procedures to resolve claims**

The following procedures are established for all civil actions filed to resolve claims subject to this article:

- (a) Within 60 days, but no earlier than 30 days, following the filing or responsive pleadings, the court shall submit the matter to nonbinding mediation unless waived by mutual stipulation of both parties. The
- (b) mediation process shall provide for the selection within 15 days of both parties of a disinterested third person as mediator, shall be commenced within 30 days of the submittal, and shall be concluded within 15 days from the commencement of the mediation unless a time requirement is extended upon a good cause showing to the court or by stipulation of both parties. If the parties fail to select a mediator within the 15 day period, any party may petition the court to appoint the mediator.
- (b)(1) If the matter remains in dispute, the case shall be submitted to judicial arbitration pursuant to Chapter 2.5 (commencing with Section 1141.10) of Title 3 of Part 3 of the Code of Civil Procedure, notwithstanding Section 1141.11 of that code. The Civil Discovery Act of 1986 (Article 3 (commencing with Section 2016) of Chapter 3 of Title 3 of Part 4 of the Code of Civil Procedure) shall apply to any proceeding brought under this subdivision consistent with the rules pertaining to judicial arbitration.
- (2) Notwithstanding any other provision of law, upon stipulation of the parties, arbitrators appointed for purposes of this article shall be experienced in construction law, and, upon stipulation of the parties, mediators and arbitrators shall be paid necessary and reasonable hourly rates of pay not to exceed their customary rate, and such fees and expenses shall be paid equally by the parties, except in the case of arbitration where the arbitrator, for good cause, determines a different division. In no event shall these fees or expenses be paid by state or county funds.
- (3) In addition to Chapter 2.5 (commencing with Section 1141.10) of Title 3 of Part 3 of the Code of Civil Procedure, any party who after receiving an arbitration award requests a trial de novo but does not obtain a more favorable judgment shall, in addition to payment of costs and fees under that chapter, pay the attorney's fees of the other party arising out of the trial de novo.
- (c) The court may, upon request by any party, order any witnesses to participate in the mediation or arbitration process.

Added Stats 1994 ch § 22 (AB 3069), effective September 21, 1994.

**Former Sections:**

Former § 20104.4 similar to present selection, was added Stats 1990 ch 1414 § 2, amended Stats 1991 ch 1029 § 2, and repealed, operative January 1, 1994, by the terms of § 20104.8.

**§ 20104.8.** [Section repealed 1993.]

Added Stats 1990 ch 1414 § 2 (AB 4165). Repealed, operative January 1, 1994, its own terms.