

1 SHEPPARD, MULLIN, RICHTER & HAMPTON LLP
 A Limited Liability Partnership
 2 Including Professional Corporations
 ARTHUR J. FRIEDMAN, Cal. Bar No. 160867
 3 ALEXANDER L. MERRITT, Cal. Bar No. 277864
 Four Embarcadero Center, 17th Floor
 4 San Francisco, California 94111-4109
 Telephone: 415.434.9100
 5 Facsimile: 415.434.3947
 E mail afriedman@sheppardmullin.com
 6 amerritt@sheppardmullin.com

7 MARY WAGNER, Cal. Bar No. 167214
 BURKE, WILLIAMS & SORENSEN LLP
 8 181 Third Street
 San Rafael, CA 94901
 9 E-mail: MWagner@bwslaw.com

10 Attorneys for Defendants
 CITY OF SAUSALITO, JILL JAMES
 11 HOFFMAN, JOHN ROHRBACHER,
 MARCIA RAINES, KENT BASSO
 12

13 UNITED STATES DISTRICT COURT
 14 NORTHERN DISTRICT OF CALIFORNIA

15 SAUSALITO/MARIN COUNTY CHAPTER
 OF THE CALIFORNIA HOMELESS UNION,
 16 on behalf of itself and those it represents;
 ROBBI POWELSON; SHERI I. RILEY;
 17 ARTHUR BRUCE; MELANIE MUASOU;
 SUNNY JEAN YOW; NAOMI
 18 MONTEMAYOR; MARK JEFF; MIKE
 19 NORTH; JACKIE CUTLER and MICHAEL
 ARNOLD on behalf of themselves and
 20 similarly situated homeless persons,

21 Plaintiffs,

22 v.

23 CITY OF SAUSALITO; MAYOR JILL
 24 JAMES HOFFMAN; POLICE CHIEF JOHN
 ROHRBACHER; CITY MANAGER
 25 MARCIA RAINES; DEPT. OF PUBLIC
 26 WORKS SUPERVISOR KENT BASSO,
 individually and in their respective official
 27 capacities,

28 Defendants.

CASE NO. 3:21-cv-01143-LB

**SECOND SUPPLEMENTAL INDEX OF
 EXHIBITS IN SUPPORT OF DEFENDANTS'
 SECOND SUPPLEMENTAL STATEMENT**

Date: December 9, 2021
 Time: 1:30 p.m.
 Courtroom: 5 – 17th Floor

Action Filed: February 16, 2021
 Trial Date: T.B.D.
 Judge: Hon. Judge Edward M. Chen

EXHIBIT 1





EXHIBIT 2







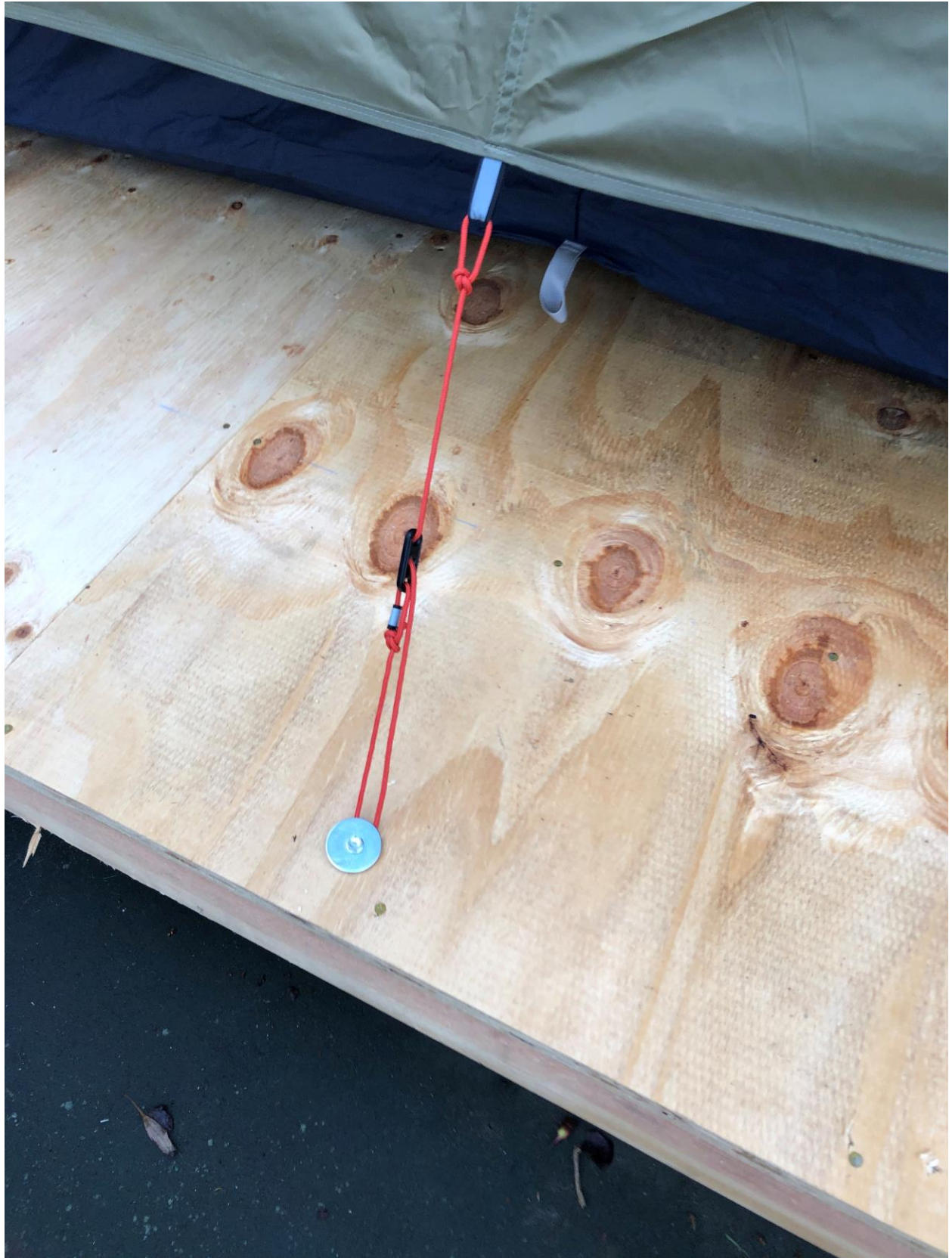
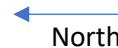

EXHIBIT 3

Marinship Park Tennis Court
Platforms



North

Concrete area
and existing
restroom

Remove portion of existing
fence (approx. 16' wide) to
allow ingress and egress

Remove existing door for
ingress and egress

Position of platforms is
approximate.

Parking lot

Small interior fence removed between
courts to allow access

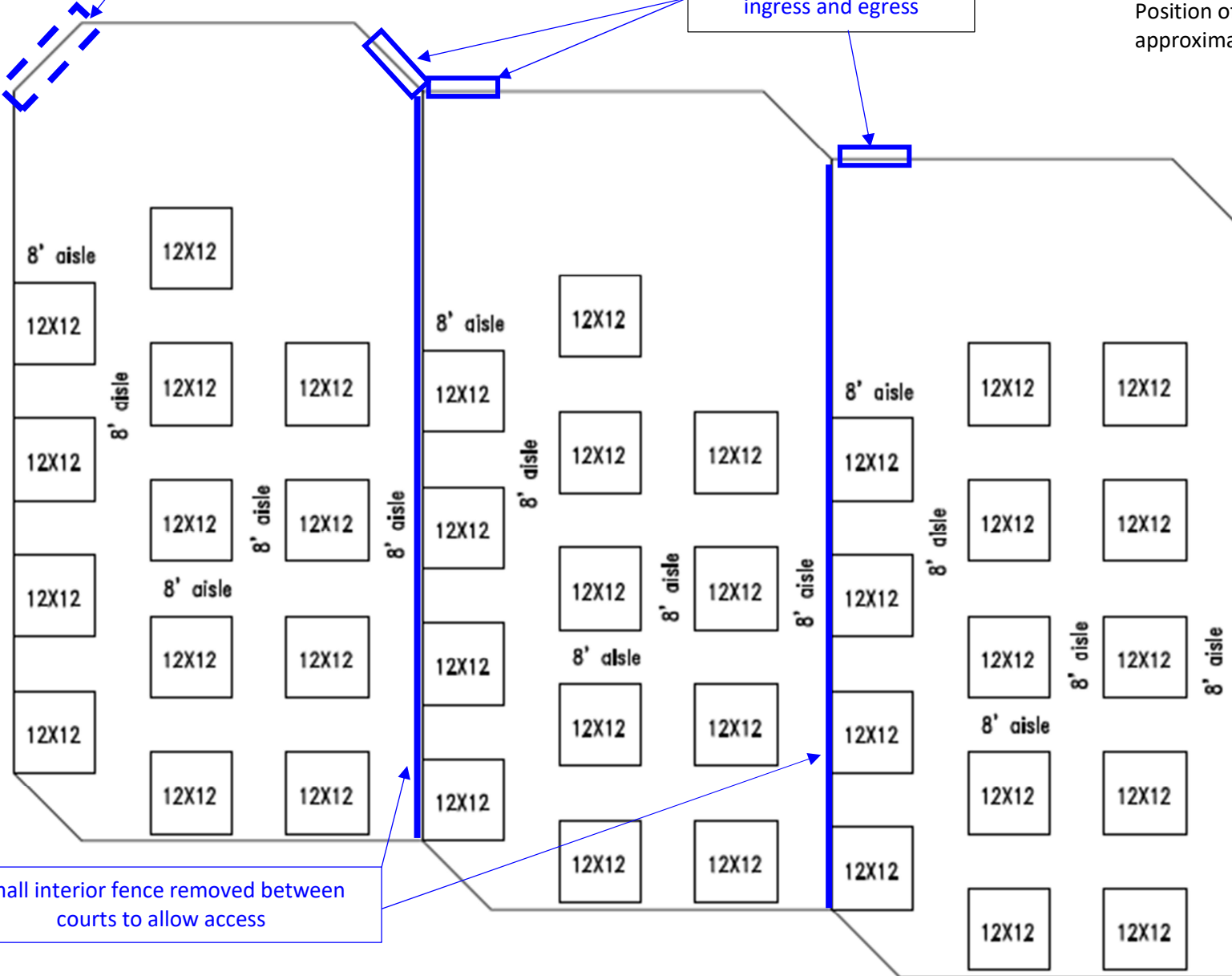

EXHIBIT 4



BETTER
TOGETHER

SOUTHERN MARIN FIRE PROTECTION DISTRICT
MILL VALLEY FIRE DEPARTMENT



FIRE PREVENTION DIVISION

28 Liberty Ship Way, Ste. 2800, Sausalito, CA 94965

Phone: (415) 380-1120 | Email: prevention@smfd.org | Web: www.smfd.org

December 7th, 2021

Attn: Heidi Scoble
City of Sausalito | Community Development Director
hscoble@sausalito.gov

Re: Fire Conditions of Approval for the Publicly Accessible Tennis Courts on APN 063-110-17

The Southern Marin Fire District (SMFD) Prevention Division has reviewed the above listed address. Based on City of Sausalito Municipal Code and the provisions of the 2019 California Fire Code (CFC) as adopted with amendments by the SMFD Ordinance No. 2019/2020-1, the following conditions shall apply to this plan review. Please note that fire department Ordinance and fire prevention standards are available on the [District's website](#) and can be located in Fire Prevention found under Our District.

Although our plan review is comprehensive and intended to be complete, non-compliant elements and conditions may occasionally be overlooked, or some elements may lack clarity, or an element may be misrepresented on the submitted plans. Please be aware non-compliant elements and conditions not addressed in plan review are subject to field review, and compliance with all applicable codes and laws will be required based on the results of the onsite inspection.

The following document(s) were reviewed:

- See '12-7-2021 Fence Openings Rev 3 12082021.pdf'.

Project Description:

- Preliminary review of the site by the City of Sausalito Building Official indicates that the intended use was not within the definitions of the Building Code as an occupancy, structure, or building. Following the determination by the City Building Official, the area has been indicated to have no formal classification from either the California Fire Code or the California Building Code. The City Building official has reviewed and approved the areas exiting and the Fire Department's review will primarily focus on the safe access to the area for emergency response. The approved plans indicate that multiple exit doors will be maintained open and clear at all times.

This review was found to be complete. The following conditions shall be applied to this project:

1. Fire Inspection Required: **A HOLD HAS BEEN PLACED ON THE FINAL INSPECTION FOR THE FIRE DISTRICT TO INSPECT THE AREA FOR SAFE ACCESS FOR EMERGENCY PERSONEL.**
2. Designated Kitchen Area requirements: **The designated kitchen area described in the reviewed plans are to always meet the minimum requirements.**

Open burning requirements under Section 307 of the 2019 California Fire Code:

- a. **307.1.1 Prohibited Open Burning** - *Open burning shall be prohibited when atmospheric conditions or local circumstances make such fires hazardous.*
- b. **307.2.1 Authorization** - *Where required by state or local law or regulations, open burning shall only be permitted with prior approval from the state or local air and water quality management authority, provided that all conditions specified in the authorization are followed.*
- c. **307.4.2 Recreational Fires** - *Recreational fires shall not be conducted within 25 feet (7620 mm) of a structure or combustible material. Conditions that could cause a fire to spread within 25 feet (7620 mm) of a structure shall be eliminated prior to ignition.*
- d. **307.5 Attendance** - *Open burning/recreational fires and use of portable outdoor fireplaces shall be constantly attended until the fire is extinguished. Not fewer than one portable fire extinguisher complying with Section 906 with a minimum 4-A rating. (Within 75 feet of travel).*
- e. **SMC 12.04.010 Outdoor fires - Conditions of issuance:** The SMFD's conditions of issuance, as defined as the Sausalito Fire Departments official designee, requires that all **recreational fires**, as defined below, are maintained in established non-combustible receptacles designed to limit the fuel area.

See below as defined in Chapter 2 of the 2019 CFC:

RECREATIONAL FIRE. *An outdoor fire burning materials other than rubbish where the fuel being burned is not contained in an incinerator, outdoor fireplace, portable outdoor fireplace, barbeque grill or barbeque pit and has a total fuel area of 3 feet (914 mm) or less in diameter and 2 feet (610 mm) or less in height for pleasure, religious, ceremonial, cooking, warmth or similar purposes.*

Note: It is unlawful for any person(s) to use open burning for the purpose of burning trash under Sausalito Municipal Code 12.24.070-12.24.080 subject to penalty under 12.04.020.

3. Any construction on this site shall comply with California Fire Code Chapter 33 – *Fire Safety During Construction and Demolition*. These requirements include but are not limited to: Temporary Heating Equipment, Precautions Against Fire, Flammable and Combustible Liquids, Flammable Gases, Owners Responsibility for Fire Protection, Fire Reporting, Access for Fire Fighting, Means of Egress, Water Supply for Fire Protection, Standpipes, Automatic Fire Sprinkler Systems, Portable Fire Extinguishers, Motorized Construction Equipment, and Safeguarding Roofing Operations.
4. Fire access to the area as well as the other surrounding properties shall be maintained at all times. Unapproved restrictions in roadway access shall result in citations and vehicles being towed at the owner's expense.

Any revisions that include additional or reduction of the area, or modifications to existing or new walls, floors, ceilings, or roofs shall be submitted as revised drawings to the Fire Department for further review.

All on-site improvements must be submitted and reviewed prior to additional fire clearance(s).

Final occupancy approval shall remain with the City of Sausalito's Building Official.

1
2
3
4
5
6
7
8
9
10
11
12
13
14
15
16
17
18
19
20
21
22
23
24
25
26
27
28

PROOF OF SERVICE

Sausalito/Marin County Chapter Of The California Homeless Union et al. v. City Of Sausalito et al.

CASE NO. 3:21-cv-01143-LB

STATE OF CALIFORNIA, COUNTY OF SAN FRANCISCO

At the time of service, I was over 18 years of age and **not a party to this action**. I am employed in the County of Orange, State of California. My business address is 650 Town Center Drive, Tenth Floor, Costa Mesa, CA 92626.

On December 8, 2021, I served true copies of the following document(s) described as: **SECOND SUPPLEMENTAL INDEX OF EXHIBITS IN SUPPORT OF DEFENDANTS' SECOND SUPPLEMENTAL STATEMENT** on the interested parties in this action as follows:

Anthony David Prince
Law Offices of Anthony D.
Prince
2425 Prince Street, #100
Berkeley, CA 94705
510-845-5475
princelawoffices@yahoo.com
Assigned: 02/16/2021

Attorney for Plaintiff:
California Homeless Union/Sausalito Chapter

BY CM/ECF NOTICE OF ELECTRONIC FILING: I electronically filed the document(s) with the Clerk of the Court by using the CM/ECF system. Participants in the case who are registered CM/ECF users will be served by the CM/ECF system. Participants in the case who are not registered CM/ECF users will be served by mail or by other means permitted by the court rules.

I declare under penalty of perjury under the laws of the United States of America that the foregoing is true and correct and that I am employed in the office of a member of the bar of this Court at whose direction the service was made.

Executed on December 8, 2021, at Costa Mesa, California.

Linda Samson