



**CITY OF SAUSALITO
PROJECT SPECIFICATIONS-BID DOCUMENTS
FOR
2022 Pavement Improvement Project**

July 2022

CITY OF SAUSALITO
MARIN COUNTY

PUBLIC WORKS DEPARTMENT
420 Litho Street
Sausalito, California 94965
(415) 289-4106

**Kevin McGowan, PE
DIRECTOR OF PUBLIC WORKS/CITY ENGINEER**

Bid Opening: August 10, 2022

Pre-Bid Conference: July 27, 2022 (Not Mandatory)

Contract Performance Time: 90 Days
Liquidated Damages: \$1,500 per Calendar Day



LOCATION MAP

City of Sausalito

TABLE OF CONTENTS

Notice Inviting Bids	1
Instructions to Bidders	3
Bid Proposal.....	9
Bid Schedule.....	12
Subcontractor List.....	14
Noncollusion Declaration	15
Bid Bond.....	16
Bidder's Questionnaire	18
Contract	21
Payment Bond.....	25
Performance Bond	27
General Conditions	29
Article 1 - Definitions.....	29
Definitions.....	29
Article 2 - Roles and Responsibilities	31
2.1 City	31
2.2 Contractor.....	32
2.3 Subcontractors	34
2.4 Coordination of Work.....	35
2.5 Submittals.....	36
2.6 Shop Drawings	36
Article 3 - Contract Documents.....	37
3.1 Interpretation of Contract Documents	37
3.2 Order of Precedence	38
3.3 Caltrans Standard Specifications	38
3.4 For Reference Only	39
3.5 Current Versions	39
3.6 Conformed Copies	39
Article 4 - Bonds, Indemnity, and Insurance	39
4.1 Payment and Performance Bonds	39
4.2 Indemnity	40
4.3 Insurance.....	40
Article 5 - Contract Time	42
5.1 Time is of the Essence	42
5.2 Schedule Requirements.....	43
5.3 Delay and Extensions of Contract Time.....	44
5.4 Liquidated Damages	48
Article 6 - Contract Modification	48
6.1 Contract Modification.....	48
6.2 Contractor Change Order Requests	49
6.3 Adjustments to Contract Price.....	50
6.4 Unilateral Change Order	51
6.5 Non-Compliance Deemed Waiver.....	51
Article 7 - General Construction Provisions.....	51
7.1 Permits, Fees, Business License, and Taxes	51
7.2 Temporary Facilities	51
7.3 Noninterference and Site Management	52
7.4 Signs.....	52
7.5 Project Site and Nearby Property Protections.....	52
7.6 Materials and Equipment.....	54
7.7 Substitutions.....	54
7.8 Testing and Inspection	55

7.9	Project Site Conditions and Maintenance	56
7.10	Instructions and Manuals	57
7.11	As-built Drawings	58
7.12	Existing Utilities	58
7.13	Notice of Excavation.....	59
7.14	Trenching and Excavations of Four Feet or More.....	59
7.15	Trenching of Five Feet or More	59
7.16	New Utility Connections	60
7.17	Lines and Grades.	60
7.18	Historic or Archeological Items.....	60
7.19	Environmental Control.....	60
7.20	Noise Control.....	61
7.21	Mined Materials.....	61
Article 8 - Payment		61
8.1	Schedule of Values	61
8.2	Progress Payments.....	61
8.3	Adjustment of Payment Application	62
8.4	Early Occupancy.	62
8.5	Retention	62
8.6	Payment to Subcontractors and Suppliers.....	63
8.7	Final Payment	64
8.8	Release of Claims	64
8.9	Warranty of Title.....	64
Article 9 - Labor Provisions.....		64
9.1	Discrimination Prohibited.....	64
9.2	Labor Code Requirements	64
9.3	Prevailing Wages	65
9.4	Payroll Records	65
9.5	Labor Compliance	65
Article 10 - Safety Provisions.....		66
10.1	Safety Precautions and Programs	66
10.2	Hazardous Materials	66
10.3	Material Safety	66
10.4	Hazardous Condition.....	67
10.5	Emergencies	67
Article 11 - Completion and Warranty Provisions.....		67
11.1	Final Completion	67
11.2	Warranty	68
11.3	Use Prior to Final Completion	69
11.4	Substantial Completion	69
Article 12 - Dispute Resolution		69
12.1	Claims.....	69
12.2	Claims Submission.....	70
12.3	City's Response	72
12.4	Meet and Confer.....	72
12.5	Mediation and Government Code Claims	72
12.6	Tort Claims	73
12.7	Arbitration	73
12.8	Burden of Proof and Limitations.....	73
12.9	Legal Proceedings.....	73
12.10	Other Disputes	73
Article 13 - Suspension and Termination.....		74
13.1	Suspension for Cause	74
13.2	Suspension for Convenience	74
13.3	Termination for Default.....	74
13.4	Termination for Convenience	76

13.5	Actions Upon Termination for Default or Convenience.....	76
Article 14 - Miscellaneous Provisions	77	
14.1	Assignment of Unfair Business Practice Claims	77
14.2	Provisions Deemed Inserted	77
14.3	Waiver	77
14.4	Titles, Headings, and Groupings	78
14.5	Statutory and Regulatory References	78
14.6	Survival.....	78
Special Conditions	79	
1.	Authorized Work Days and Hours.....	79
2.	Pre-Construction Conference	79
3.	Insurance Requirements.....	80
4.	Normal Weather Delay Days	80
5. Public Notification.....	80	
6. Alterations	80	
7. Close Out Requirements.	81	
8. Value Engineering.....	81	
TECHNICAL SPECIFICATIONS.....	82	
SECTION 10-1 – MOBILIZATION / DEMOBILIZATION.....	83	
SECTION 10-2 – CONSTRUCTION PHASING AND TRAFFIC CONTROL	84	
SECTION 10-3 – WATER POLLUTION CONTROL	86	
SECTION 10-4 – CONSTRUCTION LAYOUT	87	
SECTION 10-5 – UTILITY POTHOLING	88	
SECTION 10-6 – MONUMENT PRESERVATION	90	
SECTION 10-7 – CLEARING AND GRUBBING AND REMOVALS	91	
SECTION 10-8 – DEMOLITION	92	
SECTION 10-10 – EARTHWORK	96	
SECTION 10-11 – CONCRETE DRIVEWAY, GUTTER, AND RAMP	99	
SECTION 10-11 – ASPHALTIC CONCRETE GRINDING/MILLING	103	
SECTION 10-12 - HOT MIX ASPHALT (TYPE A)	105	
SECTION 10-13 – AGGREGATE BASE.....	109	
SECTION 10-14– PAVEMENT REPAIR	111	
SECTION 10-15 – PAVEMENT STRIPING AND MARKINGS	112	
SECTION 10-16 – CURB PAINT	115	
SECTION 17-17 – UTILITY ADJUSTMENT TO GRADE (REVOCABLE ITEM).....	116	
SECTION 10-18 – ROADSIDE SIGNS.....	118	
SECTION 10-19 – CRACK SEAL	120	

Appendices

Notice Inviting Bids

1. **Bid Submission.** City of Sausalito (“City”) will accept sealed bids for its 2022 Pavement Improvement Project (“Project”), by or before August 10, 2022, at 2:00 p.m., at its City Clerk’s office, located at 420 Litho St. Sausalito, California, at which time the bids will be publicly opened and read aloud.
2. **Project Information.**
 - 2.1 **Location and Description.** The Project is located on Platt Ave., between Toyon Ln. and Cazneau Ave., Girard Ave., between Turney St. and Johnson St. and on Johnson St., between Bridgeway and its easterly end. The Project is generally described as follows:
Mil and fill of existing asphalt concrete streets, removal and replacement of concrete streets with asphalt concrete, digout repairs, asphalt concrete overlay, storm drain replacement, curb and gutter replacement, replacement of pavement markings, new curb ramps and pavement markings.
 - 2.2 **Time for Final Completion.** The Project must be fully completed within 90 calendar days from the start date set forth in the Notice to Proceed. City anticipates that the Work will begin on or about September 19, 2022, but the anticipated start date is provided solely for convenience and is neither certain nor binding.
 - 2.3 **Estimated Cost.** The estimated construction cost is \$580,000 Base Bid and \$590,000 Base Bid plus Additive Alternate #1.
3. **License and Registration Requirements.**
 - 3.1 **License.** This Project requires a valid California contractor’s license for the following classification(s): A General Engineering.
 - 3.2 **DIR Registration.** City may not accept a Bid Proposal from or enter into the Contract with a bidder, without proof that the bidder is registered with the California Department of Industrial Relations (“DIR”) to perform public work pursuant to Labor Code § 1725.5, subject to limited legal exceptions.
4. **Contract Documents.** The plans, specifications, bid forms and contract documents for the Project, and any addenda thereto (“Contract Documents”) may be downloaded from City’s website located at: <https://www.sausalito.gov/departments/public-works/bid-notice>. A printed copy of the Contract Documents are not available.
5. **Bid Security.** The Bid Proposal must be accompanied by bid security of ten percent of the maximum bid amount, in the form of a cashier’s or certified check made payable to City, or a bid bond executed by a surety licensed to do business in the State of California on the Bid Bond form included with the Contract Documents. The bid security must guarantee that within ten days after City issues the Notice of Potential Award, the successful bidder will execute the Contract and submit the payment and performance bonds, insurance certificates and endorsements, and any other submittals required by the Contract Documents and as specified in the Notice of Potential Award.
6. **Prevailing Wage Requirements.**
 - 6.1 **General.** Pursuant to California Labor Code § 1720 et seq., this Project is subject to the prevailing wage requirements applicable to the locality in which the Work is to be performed for each craft, classification or type of worker needed to perform

the Work, including employer payments for health and welfare, pension, vacation, apprenticeship and similar purposes.

- 6.2 Rates.** The prevailing rates are on file with the City and are available online at <http://www.dir.ca.gov/DLSR>. Each Contractor and Subcontractor must pay no less than the specified rates to all workers employed to work on the Project. The schedule of per diem wages is based upon a working day of eight hours. The rate for holiday and overtime work must be at least time and one-half.
- 6.3 Compliance.** The Contract will be subject to compliance monitoring and enforcement by the DIR, under Labor Code § 1771.4.
- 7. Performance and Payment Bonds.** The successful bidder will be required to provide performance and payment bonds, each for 100% of the Contract Price, as further specified in the Contract Documents.
- 8. Substitution of Securities.** Substitution of appropriate securities in lieu of retention amounts from progress payments is permitted under Public Contract Code § 22300.
- 9. Subcontractor List.** Each Subcontractor must be registered with the DIR to perform work on public projects. Each bidder must submit a completed Subcontractor List form with its Bid Proposal, including the name, location of the place of business, California contractor license number, DIR registration number, and percentage of the Work to be performed (based on the base bid price) for each Subcontractor that will perform Work or service or fabricate or install Work for the prime contractor in excess of one-half of 1% of the bid price, using the Subcontractor List form included with the Contract Documents.
- 10. Instructions to Bidders.** All bidders should carefully review the Instructions to Bidders for more detailed information before submitting a Bid Proposal. The definitions provided in Article 1 of the General Conditions apply to all of the Contract Documents, as defined therein, including this Notice Inviting Bids.
- 11. Bidders' Conference.** A bidders' conference will be held on July 27, 2022 at 2:00 p.m., at the following location: City of Sausalito City Hall, 420 Litho St., Sausalito, CA to acquaint all prospective bidders with the Contract Documents and the Worksite. The bidders' conference is not mandatory.
- 12. Questions.** Bid questions must be in writing and can be emailed to Kevin McGowan at kmcgowan@sausalito.gov and Andrew Davidson at adavidson@sausalito.gov.
- 13.** The last day to submit for bidders questions is Wednesday August 3, 2022.

By: Serge Avila

Date: _____

City of Sausalito City Clerk

Publication Date: July 11, 2022

END OF NOTICE INVITING BIDS

Instructions to Bidders

Each Bid Proposal submitted to the City of Sausalito ("City") for its 2022 Pavement Improvement Project ("Project") must be submitted in accordance with the following instructions and requirements:

1. Bid Submission.

- 1.1 General.** Each Bid Proposal must be signed, sealed and submitted to City, using the form provided in the Contract Documents, by or before the date and time set forth in Section 1 of the Notice Inviting Bids, or as amended by subsequent addendum. Faxed or emailed Bid Proposals will not be accepted, unless otherwise specified. Late submissions will be returned unopened. City reserves the right to postpone the date or time for receiving or opening bids. Each bidder is solely responsible for all of its costs to prepare and submit its bid and by submitting a bid waives any right to recover those costs from City. The bid price(s) must include all costs to perform the Work as specified, including all labor, material, supplies, and equipment and all other direct or indirect costs such as applicable taxes, insurance and overhead.
- 1.2 Bid Envelope.** The envelope containing the sealed Bid Proposal and all required forms and attachments must be clearly labeled and addressed as follows:

BID PROPOSAL:

2022 Pavement Improvement Project
Contract No. 07.01.008

City Clerk
420 Litho St.
Sausalito, CA, 94901
Attn: Serge Avila

The envelope must also be clearly labeled, as follows, with the bidder's name, address, and its registration number with the California Department of Industrial Relations ("DIR") for bidding on public works contracts (Labor Code §§ 1725.5 and 1771.1):

[Contractor company name]
[street address]
[city, state, zip code]
DIR Registration No: _____

- 1.3 DIR Registration.** Subject to limited legal exceptions for joint venture bids and federally-funded projects, City may not accept a Bid Proposal from a bidder without proof that the bidder is registered with the DIR to perform public work under Labor Code § 1725.5. If City is unable to confirm that the bidder is currently registered with the DIR, City may disqualify the bidder and return its bid unopened. (Labor Code §§ 1725.5 and 1771.1(a).)
- 2. Bid Proposal Form and Enclosures.** Each Bid Proposal must be completed in ink using the Bid Proposal form included with the Contract Documents. The Bid Proposal form must be fully completed without interlineations, alterations, or erasures. Any necessary corrections must be clear and legible, and must be initialed by the bidder's authorized

representative. A Bid Proposal submitted with exceptions or terms such as “negotiable,” “will negotiate,” or similar, will be considered nonresponsive. Each Bid Proposal must be accompanied by bid security, as set forth in Section 4 below, and by a completed Subcontractor List and Non-Collusion Declaration using the forms included with the Contract Documents, and any other required enclosures, as applicable.

- 3. Authorization and Execution.** Each Bid Proposal must be signed by the bidder’s authorized representative. A Bid Proposal submitted by a partnership must be signed in the partnership name by a general partner with authority to bind the partnership. A Bid Proposal submitted by a corporation must be signed with the legal name of the corporation, followed by the signature and title of two officers of the corporation with full authority to bind the corporation to the terms of the Bid Proposal, under California Corporations Code § 313.
- 4. Bid Security.** Each Bid Proposal must be accompanied by bid security of ten percent of the maximum bid amount, in the form of a cashier’s check or certified check, made payable to the City, or bid bond using the form included in the Contract Documents and executed by a surety licensed to do business in the State of California. The bid security must guarantee that, within ten days after issuance of the Notice of Potential Award, the bidder will: execute and submit the enclosed Contract for the bid price; submit payment and performance bonds for 100% of the maximum Contract Price; and submit the insurance certificates and endorsements and any other submittals, if any, required by the Contract Documents or the Notice of Potential Award. A Bid Proposal may not be withdrawn for a period of 60 days after the bid opening without forfeiture of the bid security, except as authorized for material error under Public Contract Code § 5100 et seq.
- 5. Requests for Information.** Questions or requests for clarifications regarding the Project, the bid procedures, or any of the Contract Documents must be submitted in writing to Andrew Davidson, Senior Engineer, at adavidson@sausalito.gov and Kevin McGowan, Director of Public Works, at kmcgowan@sausalito.gov. Oral responses are not authorized and are not binding on the City. Bidders should submit any such written inquiries at least five Working Days before the scheduled bid opening. Questions received any later might not be addressed before the bid deadline. An interpretation or clarification by City in response to a written inquiry will be issued in an addendum.
- 6. Pre-Bid Investigation.**

 - 6.1 General.** Each bidder is solely responsible at its sole expense for diligent and thorough review of the Contract Documents, examination of the Project site, and reasonable and prudent inquiry concerning known and potential site and area conditions prior to submitting a Bid Proposal. Each bidder is responsible for knowledge of conditions and requirements which reasonable review and investigation would have disclosed. However, except for any areas that are open to the public at large, bidders may not enter property owned or leased by the City or the Project site without prior written authorization from City.
 - 6.2 Document Review.** Each bidder is responsible for review of the Contract Documents and any informational documents provided “For Reference Only,” e.g., as-builts, technical reports, test data, and the like. A bidder is responsible for notifying City of any errors, omissions, inconsistencies, or conflicts it discovers in the Contract Documents, acting solely in its capacity as a contractor and subject to the limitations of Public Contract Code § 1104. Notification of any such errors, omissions, inconsistencies, or conflicts must be submitted in writing to the City no later than five Working Days before the scheduled bid opening. (See Section 5, above.) City expressly disclaims responsibility for assumptions a bidder might draw from the presence or absence of information provided by City.

- 6.3 Project Site.** Questions regarding the availability of soil test data, water table elevations, and the like should be submitted to the City in writing, as specified in Section 5, above. Any subsurface exploration at the Project site must be done at the bidder's expense, but only with prior written authorization from City. All soil data and analyses available for inspection or provided in the Contract Documents apply only to the test hole locations. Any water table elevation indicated by a soil test report existed on the date the test hole was drilled. The bidder is responsible for determining and allowing for any differing soil or water table conditions during construction. Because groundwater levels may fluctuate, difference(s) in elevation between ground water shown in soil boring logs and ground water actually encountered during Project construction will not be considered changed Project site conditions. Actual locations and depths must be determined by bidder's field investigation. The bidder may request access to underlying or background information on the Project site in City's possession that is necessary for the bidder to form its own conclusions, including, if available, record drawings or other documents indicating the location of subsurface lines, utilities, or other structures.
- 6.4 Utility Company Standards.** The Project must be completed in a manner that satisfies the standards and requirements of any affected utility companies or agencies (collectively, "utility owners"). The successful bidder may be required by the third party utility owners to provide detailed plans prepared by a California registered civil engineer showing the necessary temporary support of the utilities during coordinated construction work. Bidders are directed to contact the affected third party utility owners about their requirements before submitting a Bid Proposal.
- 7. Bidders Interested in More Than One Bid.** No person, firm, or corporation may submit or be a party to more than one Bid Proposal unless alternate bids are specifically called for. However, a person, firm, or corporation that has submitted a subcontract proposal or quote to a bidder may submit subcontract proposals or quotes to other bidders.
- 8. Addenda.** Any addenda issued prior to the bid opening are part of the Contract Documents. Subject to the limitations of Public Contract Code § 4104.5, City reserves the right to issue addenda prior to bid time. Each bidder is solely responsible for ensuring it has received and reviewed all addenda prior to submitting its bid. Bidders should check City's website periodically for any addenda or updates on the Project at: <https://www.sausalito.gov/departments/public-works/bid-notice>.
- 9. Brand Designations and "Or Equal" Substitutions.** Any specification designating a material, product, thing, or service by specific brand or trade name, followed by the words "or equal," is intended only to indicate quality and type of item desired, and bidders may request use of any equal material, product, thing, or service. All data substantiating the proposed substitute as an equal item must be submitted with the written request for substitution. A request for substitution must be submitted within 35 days after Notice of Potential Award unless otherwise provided in the Contract Documents. This provision does not apply to materials, products, things, or services that may lawfully be designated by a specific brand or trade name under Public Contract Code § 3400(c).
- 10. Bid Protest.** Any bid protest against another bidder must be submitted in writing and received by City at 420 Litho St., Sausalito, CA 94965 or sent via email at kmcgowan@sausalito.gov before 5:00 p.m. no later than two Working Days following bid opening ("Bid Protest Deadline") and must comply with the following requirements:
- 10.1 General.** Only a bidder who has actually submitted a Bid Proposal is eligible to submit a bid protest against another bidder. Subcontractors are not eligible to

submit bid protests. A bidder may not rely on the bid protest submitted by another bidder, but must timely pursue its own protest. If required by City, the protesting bidder must submit a non-refundable fee in the amount specified by City, based upon City's reasonable costs to administer the bid protest. Any such fee must be submitted to City no later than the Bid Protest Deadline, unless otherwise specified. For purposes of this Section 10, a "Working Day" means a day that City is open for normal business, and excludes weekends and holidays observed by City. Pursuant to Public Contract Code § 4104, inadvertent omission of a Subcontractor's DIR registration number on the Subcontractor List form is not grounds for a bid protest, provided it is corrected within 24 hours of the bid opening or as otherwise provided under Labor Code § 1771.1(b).

- 10.2 Protest Contents.** The bid protest must contain a complete statement of the basis for the protest and must include all supporting documentation. Material submitted after the Bid Protest Deadline will not be considered. The protest must refer to the *specific* portion or portions of the Contract Documents upon which the protest is based. The protest must include the name, address, email address, and telephone number of the protesting bidder and any person submitting the protest on behalf of or as an authorized representative of the protesting bidder.
- 10.3 Copy to Protested Bidder.** Upon submission of its bid protest to City, the protesting bidder must also concurrently transmit the protest and all supporting documents to the protested bidder, and to any other bidder who has a reasonable prospect of receiving an award depending upon the outcome of the protest, by email or hand delivery to ensure delivery before the Bid Protest Deadline.
- 10.4 Response to Protest.** The protested bidder may submit a written response to the protest, provided the response is received by City before 5:00 p.m., within two Working Days after the Bid Protest Deadline or after actual receipt of the bid protest, whichever is sooner (the "Response Deadline"). The response must attach all supporting documentation. Material submitted after the Response Deadline will not be considered. The response must include the name, address, email address, and telephone number of the person responding on behalf of or representing the protested bidder if different from the protested bidder.
- 10.5 Copy to Protesting Bidder.** Upon submission of its response to the bid protest to the City, the protested bidder must also concurrently transmit by email or hand delivery, by or before the Response Deadline, a copy of its response and all supporting documents to the protesting bidder and to any other bidder who has a reasonable prospect of receiving an award depending upon the outcome of the protest.
- 10.6 Exclusive Remedy.** The procedure and time limits set forth in this Section are mandatory and are the bidder's sole and exclusive remedy in the event of a bid protest. A bidder's failure to comply with these procedures will constitute a waiver of any right to further pursue a bid protest, including filing a Government Code Claim or initiation of legal proceedings.
- 10.7 Right to Award.** City reserves the right, acting in its sole discretion, to reject any bid protest that it determines lacks merit, to award the Contract to the bidder it has determined to be the responsible bidder submitting the lowest responsive bid, and to issue a Notice to Proceed with the Work notwithstanding any pending or continuing challenge to its determination.

11. **Reservation of Rights.** City reserves the unfettered right, acting in its sole discretion, to waive or to decline to waive any immaterial bid irregularities; to accept or reject any or all bids; to cancel or reschedule the bid; to postpone or abandon the Project entirely; or to perform all or part of the Work with its own forces. The Contract will be awarded, if at all, within 60 days after opening of bids or as otherwise specified in the Special Conditions, to the responsible bidder that submitted the lowest responsive bid. Any planned start date for the Project represents the City's expectations at the time the Notice Inviting Bids was first issued. City is not bound to issue a Notice to Proceed by or before such planned start date, and it reserves the right to issue the Notice to Proceed when the City determines, in its sole discretion, the appropriate time for commencing the Work. The City expressly disclaims responsibility for any assumptions a bidder might draw from the presence or absence of information provided by the City in any form. Each bidder is solely responsible for its costs to prepare and submit a bid, including site investigation costs.
12. **Bonds.** Within ten calendar days following City's issuance of the Notice of Potential Award to the apparent low bidder, the bidder must submit payment and performance bonds to City as specified in the Contract Documents using the bond forms included in the Contract Documents. All required bonds must be calculated on the maximum total Contract Price as awarded, including additive alternates, if applicable.
13. **License(s).** The successful bidder and its Subcontractor(s) must possess the California contractor's license(s) in the classification(s) required by law to perform the Work. The successful bidder must also obtain a City business license within 15 days following City's issuance of the Notice of Potential Award. Subcontractors must also obtain a City business license before performing any Work.
14. **Ineligible Subcontractor.** Any Subcontractor who is ineligible to perform work on a public works project under Labor Code §§ 1777.1 or 1777.7 is prohibited from performing work on the Project.
15. **Safety Orders.** If the Project includes construction of a pipeline, sewer, sewage disposal system, boring and jacking pits, or similar trenches or open excavations, which are five feet or deeper, each bid must include a bid item for adequate sheeting, shoring, and bracing, or equivalent method, for the protection of life or limb, which comply with safety orders as required by Labor Code § 6707.
16. **Bid Schedule.** Each bidder must complete the Bid Schedule form with unit prices as indicated, and submit the completed Bid Schedule with its Bid Proposal.
 - 16.1 **Incorrect Totals.** In the event a computational error for any bid item (base bid or alternate) results in an incorrect extended total for that item, the submitted base bid or bid alternate total will be adjusted to reflect the corrected amount as the product of the estimated quantity and the unit cost. In the event of a discrepancy between the actual total of the itemized or unit prices shown on the Bid Schedule for the base bid, and the amount entered as the base bid on the Bid Proposal form, the actual total of the itemized or unit prices shown on the Bid Schedule for the base bid will be deemed the base bid price. Likewise, in the event of a discrepancy between the actual total of the itemized or unit prices shown on the Bid Schedule for any bid alternate, and the amount entered for the alternate on the Bid Proposal form, the actual total of the itemized prices shown on the Bid Schedule for that alternate will be deemed the alternate price. Nothing in this provision is intended to prevent a bidder from requesting to withdraw its bid for material error under Public Contract Code § 5100 et seq.

16.2 Estimated Quantities. Unless identified as a “Final Pay Quantity,” the quantities shown on the Bid Schedule are estimated and the actual quantities required to perform the Work may be greater or less than the estimated amount. The Contract Price will be adjusted to reflect the actual quantities required for the Work based on the itemized or unit prices provided in the Bid Schedule, with no allowance for anticipated profit for quantities that are deleted or decreased, and no increase in the unit price, and without regard to the percentage increase or decrease of the estimated quantity and the actual quantity.

17. Bidder’s Questionnaire. A completed, signed Bidder’s Questionnaire using the form provided with the Contract Documents and including all required attachments must be submitted within 48 hours following a request by City. A bid that does not fully comply with this requirement may be rejected as nonresponsive. A bidder who submits a Bidder’s Questionnaire which is subsequently determined to contain false or misleading information, or material omissions, may be disqualified as non-responsible.

18. Additive and Deductive Alternates. As required by Public Contract Code § 20103.8, if this bid solicitation includes additive or deductive items, the method checked below will be used to determine the lowest bid. If no method is checked, subparagraph (A) will be used to determine the lowest bid. City retains the right to add to or deduct from the Contract any of the additive or deductive alternates included in the Bid Proposal.

(A) The lowest bid will be the lowest bid price on the base contract without consideration of the prices on the additive or deductive items.

(B) The lowest bid will be the lowest total of the bid prices on the base contract and those additive or deductive items that were specifically identified in the bid solicitation or Bid Proposal as being used for the purpose of determining the lowest bid price.

(C) The lowest bid will be the lowest total of the bid prices on the base contract and those additive or deductive items taken in order from a specifically identified list of those items that, when in the solicitation, and added to, or subtracted from, the base contract, are less than, or equal to, a funding amount publicly disclosed by City before the first bid is opened.

(D) The lowest bid will be determined in a manner that prevents any information that would identify any of the bidders or the proposed subcontractors or suppliers from being revealed to City before the ranking of all bidders from lowest to highest has been determined.

END OF INSTRUCTIONS TO BIDDERS

Bid Proposal

2022 Pavement Improvement Project

_____ (“Bidder”) hereby submits this Bid Proposal to City of Sausalito (“City”) for the above-referenced project (“Project”) in response to the Notice Inviting Bids and in accordance with the Contract Documents referenced in the Notice.

1. **Base Bid.** Bidder proposes to perform and fully complete the Work for the Project as specified in the Contract Documents, within the time required for full completion of the Work, including all labor, materials, supplies, and equipment and all other direct or indirect costs including, but not limited to, taxes, insurance and all overhead for the following price (“Base Bid”):
\$_____.

2. **Bid Alternates.** Bidder submits the following prices for the specified bid alternates:

Alternate #1: _____ Concrete Curb & Gutter (UCS #105)
Add: \$_____

3. Sum of Base Bid plus Alternate #1 \$_____.
Lowest bid will be the lowest total of the bid prices on the base bid plus Bid Alternate #1

4. **Addenda.** Bidder agrees that it has confirmed receipt of or access to, and reviewed, all addenda issued for this bid. Bidder waives any claims it might have against the City based on its failure to receive, access, or review any addenda for any reason. Bidder specifically acknowledges receipt of the following addenda:

Addendum:	Date Received:	Addendum:	Date Received:
#01	_____	#05	_____
#02	_____	#06	_____
#03	_____	#07	_____
#04	_____	#08	_____

5. **Bidder’s Certifications and Warranties.** By signing and submitting this Bid Proposal, Bidder certifies and warrants the following:
- 5.1 **Examination of Contract Documents.** Bidder has thoroughly examined the Contract Documents and represents that, to the best of Bidder’s knowledge, there are no errors, omissions, or discrepancies in the Contract Documents, subject to the limitations of Public Contract Code § 1104.
 - 5.2 **Examination of Worksite.** Bidder has had the opportunity to examine the Worksite and local conditions at the Project location.
 - 5.3 **Bidder Responsibility.** Bidder is a responsible bidder, with the necessary ability, capacity, experience, skill, qualifications, workforce, equipment, and resources to perform or cause the Work to be performed in accordance with the Contract Documents and within the Contract Time.
 - 5.4 **Responsibility for Bid.** Bidder has carefully reviewed this Bid Proposal and is solely responsible for any errors or omissions contained in its completed bid. All statements and

information provided in this Bid Proposal and enclosures are true and correct to the best of Bidder's knowledge.

5.5 Nondiscrimination. In preparing this bid, the Bidder has not engaged in discrimination against any prospective or present employee or Subcontractor on grounds of race, color, ancestry, national origin, ethnicity, religion, sex, sexual orientation, age, disability, or marital status.

5.6 Iran Contracting Act. If the Contract Price exceeds \$1,000,000, Bidder is not identified on a list created under the Iran Contracting Act, Public Contract Code § 2200 et seq. (the "Act"), as a person engaging in investment activities in Iran, as defined in the Act, or is otherwise expressly exempt under the Act.

6. Award of Contract. By signing and submitting this Bid Proposal, Bidder agrees that if Bidder is awarded the Contract for the Project, within ten days following issuance of the Notice of Potential Award to Bidder, Bidder will do all of the following:

6.1 Execute Contract. Enter into the Contract with City in accordance with the terms of this Bid Proposal, by signing and submitting to City the Contract prepared by City using the form included with the Contract Documents;

6.2 Submit Required Bonds. Submit to City a payment bond and a performance bond, each for 100% of the Contract Price, using the bond forms provided and in accordance with the requirements of the Contract Documents; and

6.3 Insurance Requirements. Submit to City the insurance certificate(s) and endorsement(s) as required by the Contract Documents.

7. Bid Security. As a guarantee that, if awarded the Contract, Bidder will perform its obligations under Section 4 above, Bidder is enclosing bid security in the amount of ten percent of its maximum bid amount in one of the following forms (check one):

_____ A cashier's check or certified check payable to City and issued by _____ [Bank name] in the amount of \$ _____.

_____ A bid bond, using the Bid Bond form included with the Contract Documents, payable to City and executed by a surety licensed to do business in the State of California.

This Bid Proposal is hereby submitted on _____, 20__.

s/ _____

Name and Title

s/ _____
[See Section 3 of Instructions to Bidders]

Name and Title

Company Name

License #, Expiration Date, and Classification

Address

DIR Registration #

City, State, Zip

Phone

Contact Name

Contact Email

END OF BID PROPOSAL

Bid Schedule

This Bid Schedule must be completed in ink and included with the sealed Bid Proposal. Pricing must be provided for each Bid Item as indicated. Items marked "(SW)" are Specialty Work that must be performed by a qualified Subcontractor. The lump sum or unit cost for each item must be inclusive of all costs, whether direct or indirect, including profit and overhead. The sum of all amounts entered in the "Extended Total Amount" column must be identical to the Base Bid price entered in Section 1 of the Bid Proposal form.

AL = Allowance CF = Cubic Feet CY = Cubic Yard EA = Each LB = Pounds
 LF = Linear Foot LS = Lump Sum SF = Square Feet TON = Ton (2000 lbs)

ITEM No.	DESCRIPTION	QTY.	UNIT	UNIT PRICE	TOTAL
MOBILIZATION/DEMOLITION/TRAFFIC CONTROL/POLLUTION CONTROL					
1	Mobilization	1	LS		
2	Construction Phasing and Traffic Control	1	LS		
3	Water Pollution Control	1	LS		
4	Construction Layout	1	LS		
DEMOLITION					
5	Clearing & Grubbing & Removals	1	LS		
6	Asphaltic Concrete Grinding/Milling	5,880	SY		
7	Concrete and Asphalt Removal	19,100	SF		
STREET IMPROVEMENTS					
8	Concrete Gutter	8	LF		
9	Concrete Curb & Gutter (UCS #105)	4	LF		
10	Concrete Curb Ramp	2	EA		
11	Hot Mix Asphalt (Type A)	1,200	TN		
12	Pavement Fabric	5,780	SY		
13	HMA Shallow Digout	330	SF		
14	HMA Deep Digout	1,200	SF		
UTILITY ADJUSTMENTS TO GRADE					
15	Utility Adjustment - Water Valve (Revocable)	35	EA		
16	Utility Adjustment - Sewer Rodding Inlet	4	EA		
17	Adjust Sanitary Sewer Manhole to Grade	3	EA		
18	Adjust Electrical Box to Grade (Revocable)	1	EA		
19	Adjust Telecom Manhole Cover to Grade (Revocable)	1	EA		
20	Adjust Traffic Box to Grade	1	EA		
SIGNING & STRIPING					
21	Pavement Markings	1	LS		
22	Curb Paint	1	LS		
23	Reset Roadside Sign	1	EA		

* Final Pay Quantity

TOTAL BASE BID: Items 1 through 23 inclusive: \$ _____

Note: The amount entered as the "Total Base Bid" should be identical to the Base Bid amount entered in Section 1 of the Bid Proposal form.

BIDDER NAME: _____

BID SCHEDULE
BID ALTERNATIVE #1

BID ITEM NO.	ITEM DESCRIPTION	EST. QTY.	UNIT	UNIT COST	EXTENDED TOTAL AMOUNT
9a	Concrete Curb & Gutter (UCS #105)	34	LF	\$	\$

TOTAL BID ALTERNATIVE #1: Items 9a \$ _____

Note: The amount entered as the "Total Bid Alternate #1" should be identical to the Alternate #1 amount entered in Section 1 of the Bid Proposal form.

Sum Total Base Bid plus Total Bid Alternative #1:
\$ _____

BIDDER NAME: _____

END OF BID SCHEDULE

Noncollusion Declaration

TO BE EXECUTED BY BIDDER AND SUBMITTED WITH BID

The undersigned declares:

I am the _____ [title] of _____
[business name], the party making the foregoing bid.

The bid is not made in the interest of, or on behalf of, any undisclosed person, partnership, company, association, organization, or corporation. The bid is genuine and not collusive or sham. The bidder has not directly or indirectly induced or solicited any other bidder to put in a false or sham bid. The bidder has not directly or indirectly colluded, conspired, connived, or agreed with any bidder or anyone else to put in a sham bid, or to refrain from bidding. The bidder has not in any manner, directly or indirectly, sought by agreement, communication, or conference with anyone to fix the bid price of the bidder or any other bidder, or to fix any overhead, profit, or cost element of the bid price, or of that of any other bidder. All statements contained in the bid are true. The bidder has not, directly or indirectly, submitted his or her bid price or any breakdown thereof, or the contents thereof, or divulged information or data relative thereto, to any corporation, partnership, company, association, organization, bid depository, or to any member or agent thereof, to effectuate a collusive or sham bid, and has not paid and will not pay, any person or entity for such purpose.

This declaration is intended to comply with California Public Contract Code § 7106 and Title 23 U.S.C § 112.

I declare under penalty of perjury under the laws of the State of California that the foregoing is true and correct and that this declaration is executed on _____ [date], at _____ [city], _____ [state].

s/ _____

Name [print]

END OF NONCOLLUSION DECLARATION

Bid Bond

_____ (“Bidder”) has submitted a bid, dated _____, 20____ (“Bid”), to City of Sausalito (“City”) for work on the 2022 Pavement Improvement Project (“Project”). Under this duly executed bid bond (“Bid Bond”), Bidder as Principal and _____, its surety (“Surety”), are bound to City as obligee in the penal sum of ten percent of the maximum amount of the Bid (the “Bond Sum”). Bidder and Surety bind themselves and their respective heirs, executors, administrators, successors and assigns, jointly and severally, as follows:

1. **General.** If Bidder is awarded the Contract for the Project, Bidder will enter into the Contract with City in accordance with the terms of the Bid.
2. **Submittals.** Within ten days following issuance of the Notice of Potential Award to Bidder, Bidder must submit to City the following:
 - 2.1 **Contract.** The executed Contract, using the form provided by City in the Project contract documents (“Contract Documents”);
 - 2.2 **Payment Bond.** A payment bond for 100% of the maximum Contract Price, executed by a surety licensed to do business in the State of California using the Payment Bond form included with the Contract Documents;
 - 2.3 **Performance Bond.** A performance bond for 100% of the maximum Contract Price, executed by a surety licensed to do business in the State of California using the Performance Bond form included with the Contract Documents; and
 - 2.4 **Insurance.** The insurance certificate(s) and endorsement(s) required by the Contract Documents, and any other documents required by the Instructions to Bidders or Notice of Potential Award.
3. **Enforcement.** If Bidder fails to execute the Contract and to submit the bonds and insurance certificates as required by the Contract Documents, Surety guarantees that Bidder forfeits the Bond Sum to City. Any notice to Surety may be given in the manner specified in the Contract and delivered or transmitted to Surety as follows:

Attn: _____
Address: _____
City/State/Zip: _____
Phone: _____
Fax: _____
Email: _____

4. **Duration and Waiver.** If Bidder fulfills its obligations under Section 2, above, then this obligation will be null and void; otherwise, it will remain in full force and effect for 60 days following the bid opening or until this Bid Bond is returned to Bidder, whichever occurs first. Surety waives the provisions of Civil Code §§ 2819 and 2845.

[Signatures are on the following page.]

This Bid Bond is entered into and effective on _____, 20_____.

SURETY:

Business Name

s/ _____

Date

Name, Title

(Attach Acknowledgment with Notary Seal and Power of Attorney)

BIDDER:

Business Name

s/ _____

Date

Name, Title

END OF BID BOND

Bidder's Questionnaire

2022 PAVEMENT IMPROVEMENT PROJECT

Within 48 hours following a request by City, a bidder must submit to City a completed, signed Bidder's Questionnaire using this form and all required attachments, including clearly labeled additional sheets as needed. City may request the Questionnaire from one or more of the apparent low bidders following the bid opening, and may use the completed Questionnaire as part of its investigation to evaluate a bidder's qualifications for this Project. The Questionnaire must be filled out completely, accurately, and legibly. Any errors, omissions, or misrepresentations in completion of the Questionnaire may be grounds for rejection of the bid or termination of a Contract awarded pursuant to the bid.

Part A: General Information

Bidder Business Name: _____ ("Bidder")

Check One: Corporation (State of incorporation: _____)
 Partnership
 Sole Proprietorship
 Joint Venture of: _____
 Other: _____

Main Office Address and Phone: _____

Local Office Address and Phone: _____

Website address: _____

Owner of Business: _____

Contact Name and Title: _____

Contact Phone and Email: _____

Bidder's California Contractor's License Number(s): _____

Bidder's DIR Registration Number: _____

Part B: Bidder Experience

1. How many years has Bidder been in business under its present business name? ____ years
2. Has Bidder completed projects similar in type and size to this Project as a general contractor?
____ Yes ____ No
3. Has Bidder ever been disqualified from a bid on grounds that it is not responsible, or otherwise disqualified or disbarred from bidding under state or federal law?
____ Yes ____ No

If yes, provide additional information on a separate sheet regarding the disqualification or disbarment, including the name and address of the agency or owner of the project, the type and size of the project, the reasons that Bidder was disqualified or disbarred, and the month and year in which the disqualification or disbarment occurred.

4. Has Bidder ever been terminated for cause, alleged default, or legal violation from a construction project, either as a general contractor or as a subcontractor?

_____ Yes _____ No

If yes, provide additional information on a separate sheet regarding the termination, including the name and address of the agency or owner of the subject project, the type and size of the project, whether Bidder was under contract as a general contractor or a subcontractor, the reasons that Bidder was terminated, and the month and year in which the termination occurred.

5. Provide information about Bidder's past projects performed as general contractor as follows:

- 5.1 Six most recently completed public works projects within the last three years;
- 5.2 Three largest completed projects within the last three years; and
- 5.3 Any project which is similar to this Project including scope and character of the work.

6. Use separate sheets to provide all of the following information for each project identified in response to the above three categories:

- 6.1 Project name, location, and description;
- 6.2 Owner (name, address, email, and phone number);
- 6.3 Prime contractor, if applicable (name, address, email, and phone number);
- 6.4 Architect or engineer (name, email, and phone number);
- 6.5 Project and/or construction manager (name, email, and phone number);
- 6.6 Scope of work performed (as general or as subcontractor);
- 6.7 Initial contract price and final contract price (including change orders);
- 6.8 Original scheduled completion date and actual date of completion;
- 6.9 Time extensions granted (number of days);
- 6.10 Number and amount of stop notices or mechanic's liens filed;
- 6.11 Amount of any liquidated damages assessed against Bidder; and
- 6.12 Nature and resolution of any project-related claim, lawsuit, mediation, or arbitration involving Bidder.

Part C: Safety

1. Provide Bidder's Experience Modification Rate (EMR) for the last three years:

Year	EMR

2. Complete the following, based on information provided in Bidder's CalOSHA Form 300 or Form 300A, Annual Summary of Work-Related Illnesses and Injuries, from the most recent past calendar year:

- 2.1 Number of lost workday cases: _____
- 2.2 Number of medical treatment cases: _____
- 2.3 Number of deaths: _____

3. Has Bidder ever been cited, fined, or prosecuted by any local, state, or federal agency, including OSHA, CalOSHA, or EPA, for violation of any law, regulation, or requirements pertaining to health and safety?

_____ Yes _____ No

If yes, provide additional information on a separate sheet regarding each such citation, fine, or prosecution, including the name and address of the agency or owner of the project, the type and size of the project, the reasons for and nature of the citation, fine, or prosecution, and the month and year in which the incident giving rise to the citation, fine, or prosecution occurred.

4. Name, title, and email for person responsible for Bidder's safety program:

_____	_____	_____
Name	Title	Email

Part D: Verification

In signing this document, I, the undersigned, declare that I am duly authorized to sign and submit this Bidder's Questionnaire on behalf of the named Bidder, and that all responses and information set forth in this Bidder's Questionnaire and accompanying attachments are, to the best of my knowledge, true, accurate and complete as of the date of submission. **I declare under penalty of perjury under the laws of the State of California that the foregoing is true and correct.**

Signature: _____ Date: _____

By: _____
Name and Title

END OF BIDDER'S QUESTIONNAIRE

Contract

This public works contract ("Contract") is entered into by and between City of Sausalito ("City") and _____ ("Contractor"), for work on the 2022 Pavement Improvement Project ("Project").

The parties agree as follows:

1. **Award of Contract.** In response to the Notice Inviting Bids, Contractor has submitted a Bid Proposal to perform the Work to construct the Project. On _____, 20____, City authorized award of this Contract to Contractor for the amount set forth in Section 4, below.
2. **Contract Documents.** The Contract Documents incorporated into this Contract include and are comprised of all of the documents listed below. The definitions provided in Article 1 of the General Conditions apply to all of the Contract Documents, including this Contract.
 - 2.1 Notice Inviting Bids;
 - 2.2 Instructions to Bidders;
 - 2.3 Addenda, if any;
 - 2.4 Bid Proposal and attachments thereto;
 - 2.5 Contract;
 - 2.6 Payment and Performance Bonds;
 - 2.7 General Conditions;
 - 2.8 Special Conditions;
 - 2.9 Project Plans and Specifications;
 - 2.10 Change Orders, if any;
 - 2.11 Notice of Potential Award;
 - 2.12 Notice to Proceed; and
 - 2.13 The following: No other documents
3. **Contractor's Obligations.** Contractor will perform all of the Work required for the Project, as specified in the Contract Documents. Contractor must provide, furnish, and supply all things necessary and incidental for the timely performance and completion of the Work, including all necessary labor, materials, supplies, tools, equipment, transportation, onsite facilities, and utilities, unless otherwise specified in the Contract Documents. Contractor must use its best efforts to diligently prosecute and complete the Work in a professional and expeditious manner and to meet or exceed the performance standards required by the Contract Documents.
4. **Payment.** As full and complete compensation for Contractor's timely performance and completion of the Work in strict accordance with the terms and conditions of the Contract Documents, City will pay Contractor \$ _____ ("Contract Price") for all of Contractor's direct and indirect costs to perform the Work, including all labor, materials, supplies, equipment, taxes, insurance, bonds and all overhead costs, in accordance with the payment provisions in the General Conditions.
5. **Time for Completion.** Contractor will fully complete the Work for the Project, meeting all requirements for Final Completion, within 90 calendar days from the commencement date given in the Notice to Proceed ("Contract Time"). By signing below, Contractor expressly waives any claim for delayed early completion.
6. **Liquidated Damages.** As further specified in Section 5.4 of the General Conditions, if Contractor fails to complete the Work within the Contract Time, City will assess liquidated damages in the amount of 1,500 per day for each day of unexcused delay in achieving

Final Completion, and such liquidated damages may be deducted from City's payments due or to become due to Contractor under this Contract.

7. Labor Code Compliance.

7.1 General. This Contract is subject to all applicable requirements of Chapter 1 of Part 7 of Division 2 of the Labor Code, including requirements pertaining to wages, working hours and workers' compensation insurance, as further specified in Article 9 of the General Conditions.

7.2 Prevailing Wages. This Project is subject to the prevailing wage requirements applicable to the locality in which the Work is to be performed for each craft, classification or type of worker needed to perform the Work, including employer payments for health and welfare, pension, vacation, apprenticeship and similar purposes. Copies of these prevailing rates are available online at <http://www.dir.ca.gov/DLSR>.

7.3 DIR Registration. City may not enter into the Contract with a bidder without proof that the bidder and its Subcontractors are registered with the California Department of Industrial Relations to perform public work pursuant to Labor Code § 1725.5, subject to limited legal exceptions.

8. Workers' Compensation Certification. Pursuant to Labor Code § 1861, by signing this Contract, Contractor certifies as follows: "I am aware of the provisions of Labor Code § 3700 which require every employer to be insured against liability for workers' compensation or to undertake self-insurance in accordance with the provisions of that code, and I will comply with such provisions before commencing the performance of the Work on this Contract."

9. Conflicts of Interest. Contractor, its employees, Subcontractors and agents, may not have, maintain or acquire a conflict of interest in relation to this Contract in violation of any City ordinance or requirement, or in violation of any California law, including Government Code § 1090 et seq., or the Political Reform Act, as set forth in Government Code § 81000 et seq. and its accompanying regulations. Any violation of this Section constitutes a material breach of the Contract.

10. Independent Contractor. Contractor is an independent contractor under this Contract and will have control of the Work and the means and methods by which it is performed. Contractor and its Subcontractors are not employees of City and are not entitled to participate in any health, retirement, or any other employee benefits from City.

11. Notice. Any notice, billing, or payment required by or pursuant to the Contract Documents must be made in writing, signed, dated and sent to the other party by personal delivery, U.S. Mail, a reliable overnight delivery service, or by email as a PDF file. Notice is deemed effective upon delivery, except that service by U.S. Mail is deemed effective on the second working day after deposit for delivery. Notice for each party must be given as follows:

City:

City of Sausalito
420 Litho St.
Sausalito, CA 94965
Attn: Andrew Davidson, Senior Engineer
adavidson@sausalito.gov

Copy to: Kevin McGowan, Public Works Director
kmcgowan@sausalito.gov

Contractor:

Name: _____
Address: _____
City/State/Zip: _____
Phone: _____
Attn: _____
Email: _____
Copy to: _____

12. General Provisions.

- 12.1 Assignment and Successors.** Contractor may not assign its rights or obligations under this Contract, in part or in whole, without City’s written consent. This Contract is binding on Contractor’s and City’s lawful heirs, successors and permitted assigns.
- 12.2 Third Party Beneficiaries.** There are no intended third party beneficiaries to this Contract.
- 12.3 Governing Law and Venue.** This Contract will be governed by California law and venue will be in the Marin County Superior Court, and no other place. Contractor waives any right it may have pursuant to Code of Civil Procedure § 394, to file a motion to transfer any action arising from or relating to this Contract to a venue outside of Marin County, California.
- 12.4 Amendment.** No amendment or modification of this Contract will be binding unless it is in a writing duly authorized and signed by the parties to this Contract.
- 12.5 Integration.** This Contract and the Contract Documents incorporated herein, including authorized amendments or Change Orders thereto, constitute the final, complete, and exclusive terms of the agreement between City and Contractor.
- 12.6 Severability.** If any provision of the Contract Documents is determined to be illegal, invalid, or unenforceable, in whole or in part, the remaining provisions of the Contract Documents will remain in full force and effect.
- 12.7 Iran Contracting Act.** If the Contract Price exceeds \$1,000,000, Contractor certifies, by signing below, that it is not identified on a list created under the Iran Contracting Act, Public Contract Code § 2200 et seq. (the “Act”), as a person engaging in investment activities in Iran, as defined in the Act, or is otherwise expressly exempt under the Act.
- 12.8 Authorization.** Each individual signing below warrants that he or she is authorized to do so by the party that he or she represents, and that this Contract is legally binding on that party. If Contractor is a corporation, signatures from two officers of the corporation are required pursuant to California Corporation Code § 313.

The parties agree to this Contract as witnessed by the signatures below:

CITY:

Approved as to form:

s/ _____

Chris Zapata, City Manager
Name, Title

Date: _____

s/ _____

Mary Wagner, City Attorney
Name, Title

Date: _____

Attest:

s/ _____

Serge Avila, City Clerk
Name, Title

Date: _____

CONTRACTOR: _____
Business Name

s/ _____

Seal:

Name, Title

Date: _____

Second Signature (See Section 12.8):

s/ _____

Name, Title

Date: _____

Contractor's California License Number(s) and Expiration Date(s)

END OF CONTRACT

Payment Bond

City of Sausalito ("City") and _____ ("Contractor") have entered into a contract for work on the 2022 Pavement Improvement Project ("Project"). The Contract is incorporated by reference into this Payment Bond ("Bond").

- 1. General.** Under this Bond, Contractor as principal and _____, its surety ("Surety"), are bound to City as obligee in an amount not less than \$_____, under California Civil Code § 9550 et seq., to ensure payment to authorized claimants. This Bond is binding on the respective successors, assigns, owners, heirs, or executors of Surety and Contractor.
- 2. Surety's Obligation.** If Contractor or any of its Subcontractors fails to pay a person authorized in California Civil Code § 9100 to assert a claim against a payment bond, any amounts due under the Unemployment Insurance Code with respect to work or labor performed under the Contract, or any amounts required to be deducted, withheld, and paid over to the Employment Development Department from the wages of employees of Contractor and its Subcontractors under California Unemployment Insurance Code § 13020 with respect to the work and labor, then Surety will pay the obligation.
- 3. Beneficiaries.** This Bond inures to the benefit of any of the persons named in California Civil Code § 9100, so as to give a right of action to those persons or their assigns in any suit brought upon this Bond. Contractor must promptly provide a copy of this Bond upon request by any person with legal rights under this Bond.
- 4. Duration.** If Contractor promptly makes payment of all sums for all labor, materials, and equipment furnished for use in the performance of the Work required by the Contract, in conformance with the time requirements set forth in the Contract and as required by California law, Surety's obligations under this Bond will be null and void. Otherwise, Surety's obligations will remain in full force and effect.
- 5. Waivers.** Surety waives any requirement to be notified of alterations to the Contract or extensions of time for performance of the Work under the Contract. Surety waives the provisions of Civil Code §§ 2819 and 2845. City waives the requirement of a new bond for any supplemental contract under Civil Code § 9550. Any notice to Surety may be given in the manner specified in the Contract and delivered or transmitted to Surety as follows:

Attn: _____
Address: _____
City/State/Zip: _____
Phone: _____
Email: _____

- 6. Law and Venue.** This Bond will be governed by California law, and venue for any dispute pursuant to this Bond will be in the Marin County Superior Court, and no other place. Surety will be responsible for City's attorneys' fees and costs in any action to enforce the provisions of this Bond.

[Signatures are on the following page.]

7. **Effective Date; Execution.** This Bond is entered into and is effective on _____,
20__.

SURETY:

Business Name

s/ _____

Date

Name, Title

(Attach Acknowledgment with Notary Seal and Power of Attorney)

CONTRACTOR:

Business Name

s/ _____

Date

Name, Title

APPROVED BY CITY:

s/ _____

Date

Kevin McGowan, Director of Public Works
Name, Title

END OF PAYMENT BOND

Performance Bond

City of Sausalito ("City") and _____ ("Contractor") have entered into a contract for work on the 2022 Pavement Improvement Project ("Project"). The Contract is incorporated by reference into this Performance Bond ("Bond").

1. **General.** Under this Bond, Contractor as principal and _____, its surety ("Surety"), are bound to City as obligee for an amount not less than \$_____ to ensure Contractor's faithful performance of its obligations under the Contract. This Bond is binding on the respective successors, assigns, owners, heirs, or executors of Surety and Contractor.
2. **Surety's Obligations.** Surety's obligations are co-extensive with Contractor's obligations under the Contract. If Contractor fully performs its obligations under the Contract, including its warranty obligations under the Contract, Surety's obligations under this Bond will become null and void. Otherwise, Surety's obligations will remain in full force and effect.
3. **Waiver.** Surety waives any requirement to be notified of and further consents to any alterations to the Contract made under the applicable provisions of the Contract Documents, including changes to the scope of Work or extensions of time for performance of Work under the Contract. Surety waives the provisions of Civil Code §§ 2819 and 2845.
4. **Application of Contract Balance.** Upon making a demand on this Bond for completion of the Work prior to acceptance of the Project, City will make the Contract Balance available to Surety for completion of the Work under the Contract. For purposes of this provision, the Contract Balance is defined as the total amount payable by City to Contractor as the Contract Price minus amounts already paid to Contractor, and minus any liquidated damages, credits, or backcharges to which City is entitled under the terms of the Contract.
5. **Contractor Default.** Upon written notification from City of Contractor's termination for default under Article 13 of the Contract General Conditions, time being of the essence, Surety must act within the time specified in Article 13 to remedy the default through one of the following courses of action:
 - 5.1 Arrange for completion of the Work under the Contract by Contractor, with City's consent, but only if Contractor is in default solely due to its financial inability to complete the Work;
 - 5.2 Arrange for completion of the Work under the Contract by a qualified contractor acceptable to City, and secured by performance and payment bonds issued by an admitted surety as required by the Contract Documents, at Surety's expense; or
 - 5.3 Waive its right to complete the Work under the Contract and reimburse City the amount of City's costs to have the remaining Work completed.
6. **Surety Default.** If Surety defaults on its obligations under the Bond, City will be entitled to recover all costs it incurs due to Surety's default, including legal, design professional, or delay costs.
7. **Notice.** Any notice to Surety may be given in the manner specified in the Contract and sent to Surety as follows:

Attn: _____

Address: _____

City/State/Zip: _____
Phone: _____
Fax: _____
Email: _____

8. **Law and Venue.** This Bond will be governed by California law, and venue for any dispute pursuant to this Bond will be in the Marin County Superior Court, and no other place. Surety will be responsible for City's attorneys' fees and costs in any action to enforce the provisions of this Bond.
9. **Effective Date; Execution.** This Bond is entered into and effective on _____, 20____.

SURETY:

Business Name

s/ _____

Date

Name, Title

(Attach Acknowledgment with Notary Seal and Power of Attorney)

CONTRACTOR:

Business Name

s/ _____

Date

Name, Title

APPROVED BY CITY:

s/ _____

Date

Kevin McGowan, Director of Public Works
Name, Title

END OF PERFORMANCE BOND

General Conditions

Article 1 - Definitions

Definitions. The following definitions apply to all of the Contract Documents unless otherwise indicated, e.g., additional definitions that apply solely to the Specifications or other technical documents. Defined terms and titles of documents are capitalized in the Contract Documents, with the exception of the following (in any tense or form): “day,” “furnish,” “including,” “install,” “work day” or “working day.”

Allowance means a specific amount that must be included in the Bid Proposal for a specified purpose.

Article, as used in these General Conditions, means a numbered Article of the General Conditions, unless otherwise indicated by the context.

Change Order means a written document duly approved and executed by City, which changes the scope of Work, the Contract Price, or the Contract Time.

City means the municipality which has entered into the Contract with Contractor for performance of the Work, acting through its City Council, officers, employees, City Engineer, and any other authorized representatives.

City Engineer means the City Engineer for City and his or her authorized delegee(s).

Claim means a separate demand by Contractor for a change in the Contract Time or Contract Price, that has previously been submitted to City in accordance with the requirements of the Contract Documents, and which has been rejected by City, in whole or in part; or a written demand by Contractor objecting to the amount of Final Payment.

Contract means the signed agreement between City and Contractor for performing the Work required for the Project, and all documents expressly incorporated therein.

Contract Documents means, collectively, all of the documents listed as such in Section 2 of the Contract, including the Notice Inviting Bids; the Instructions to Bidders; addenda, if any; the Bid Proposal, and attachments thereto; the Contract; the Notice of Potential Award and Notice to Proceed; the payment and performance bonds; the General Conditions; the Special Conditions; the Project Plans and Specifications; any Change Orders; and any other documents which are clearly and unambiguously made part of the Contract Documents. The Contract Documents do not include documents provided “For Reference Only,” or documents that are intended solely to provide information regarding existing conditions.

Contract Price means the total compensation to be paid to Contractor for performance of the Work, as set forth in the Contract and as may be amended by Change Order or adjusted for an Allowance. The Contract Price is not subject to adjustment due to inflation or due to the increased cost of labor, material, supplies or equipment following submission of the Bid Proposal.

Contract Time means the time specified for complete performance of the Work, as set forth in the Contract and as may be amended by Change Order.

Contractor means the individual, partnership, corporation, or joint-venture that has signed the Contract with City to perform the Work.

Day means a calendar day unless otherwise specified.

Design Professional means the licensed individual(s) or firm(s) retained by City to provide architectural, engineering, or electrical engineering design services for the Project. If no Design Professional has been retained for this Project, any reference to Design Professional is deemed to refer to the Engineer.

DIR means the California Department of Industrial Relations.

Drawings has the same meaning as Plans.

Engineer means the City Engineer for the City of Sausalito and his or her authorized delegates.

Excusable Delay is defined in Section 5.3(B), Excusable Delay.

Extra Work means new or unforeseen work added to the Project, as determined by the Engineer in his or her sole discretion, including Work that was not part of or incidental to the scope of the Work when the Contractor's bid was submitted; Work that is substantially different from the Work as described in the Contract Documents at bid time; or Work that results from a substantially differing and unforeseeable condition.

Final Completion means Contractor has fully completed all of the Work required by the Contract Documents to the City's satisfaction, including all punch list items and any required commissioning or training, and has provided the City with all required submittals, including the instructions and manuals, product warranties, and as-built drawings.

Final Payment means payment to Contractor of the unpaid Contract Price, including release of undisputed retention, less amounts withheld or deducted pursuant to the Contract Documents.

Furnish means to purchase and deliver for the Project.

Government Code Claim means a claim submitted pursuant to California Government Code § 900 et seq.

Hazardous Materials means any substance or material identified now or in the future as hazardous under any Laws, or any other substance or material that may be considered hazardous or otherwise subject to Laws governing handling, disposal, or cleanup.

Including, whether or not capitalized, means "including, but not limited to," unless the context clearly requires otherwise.

Inspector means the individual(s) or firm(s) retained or employed by City to inspect the workmanship, materials, and manner of construction of the Project and its components to ensure compliance with the Contract Documents and all Laws.

Install means to fix in place for materials, and to fix in place and connect for equipment.

Laws means all applicable local, state, and federal laws, regulations, rules, codes, ordinances, permits, orders, and the like enacted or imposed by or under the auspices of any governmental entity with jurisdiction over any of the Work or any performance of the Work, including health and safety requirements.

Non-Excusable Delay is defined in Section 5.3(D), Non-Excusable Delay.

Plans means the City-provided plans, drawings, details, or graphical depictions of the Project requirements, but does not include Shop Drawings.

Project means the public works project referenced in the Contract.

Project Manager means the individual designated by City to oversee and manage the Project on City's behalf and may include his or her authorized delegee(s) when the Project Manager is unavailable. If no Project Manager has been designated for this Project, any reference to Project Manager is deemed to refer to the Engineer.

Recoverable Costs is defined in Section 5.3(F), Recoverable Costs.

Request for Information or **RFI** means Contractor's written request for information about the Contract Documents, the Work or the Project, submitted to City in the manner and format specified by City.

Section, when capitalized in these General Conditions, means a numbered section or subsection of the General Conditions, unless the context clearly indicates otherwise.

Shop Drawings means drawings, plan details or other graphical depictions prepared by or on behalf of Contractor, and subject to City acceptance, which are intended to provide details for fabrication, installation, and the like, of items required by or shown in the Plans or Specifications.

Specialty Work means Work that must be performed by a specialized Subcontractor with the specified license or other special certification, and that the Contractor is not qualified to self-perform.

Specifications means the technical, text specifications describing the Project requirements, which are prepared for and incorporated into the Contract by or on behalf of City, and does not include the Contract, General Conditions or Special Conditions.

Subcontractor means an individual, partnership, corporation, or joint-venture retained by Contractor directly or indirectly through a subcontract to perform a specific portion of the Work. The term Subcontractor applies to subcontractors of all tiers, unless otherwise indicated by the context. A third party such as a utility performing related work on the Project is not a Subcontractor, even if Contractor must coordinate its Work with the third party.

Technical Specifications has the same meaning as Specifications.

Work means all of the construction and services necessary for or incidental to completing the Project in conformance with the requirements of the Contract Documents.

Work Day or **Working Day**, whether or not capitalized, means a weekday when the City is open for business, and does not include holidays observed by the City.

Worksite means the place or places where the Work is performed, which includes, but may extend beyond the Project site, including separate locations for staging, storage, or fabrication.

Article 2 - Roles and Responsibilities

2.1 City.

(A) **City Council.** The City Council has final authority in all matters affecting the Project, except to the extent it has delegated authority to the Engineer.

(B) **Engineer.** The Engineer, acting within the authority conferred by the City Council, is responsible for administration of the Project on behalf of City, including authority to provide directions to the Design Professional and to Contractor to ensure proper and timely completion of the Project. The Engineer's decisions are final and

conclusive within the scope of his or her authority, including interpretation of the Contract Documents.

(C) **Project Manager.** The Project Manager assigned to the Project will be the primary point of contact for the Contractor and will serve as City's representative for daily administration of the Project on behalf of City. Unless otherwise specified, all of Contractor's communications to City (in any form) will go to or through the Project Manager. City reserves the right to reassign the Project Manager role at any time or to delegate duties to additional City representatives, without prior notice to or consent of Contractor.

(D) **Design Professional.** The Design Professional is responsible for the overall design of the Project and, to the extent authorized by City, may act on City's behalf to ensure performance of the Work in compliance with the Plans and Specifications, including any design changes authorized by Change Order. The Design Professional's duties may include review of Contractor's submittals, visits to any Worksite, inspecting the Work, evaluating test and inspection results, and participation in Project-related meetings, including any pre-construction conference, weekly meetings, and coordination meetings. The Design Professional's interpretation of the Plans or Specifications is final and conclusive.

2.2 Contractor.

(A) **General.** Contractor must provide all labor, materials, supplies, equipment, services, and incidentals necessary to perform and timely complete the Work in strict accordance with the Contract Documents, and in an economical and efficient manner in the best interests of City, and with minimal inconvenience to the public.

(B) **Responsibility for the Work and Risk of Loss.** Contractor is responsible for supervising and directing all aspects of the Work to facilitate the efficient and timely completion of the Work. Contractor is solely responsible for and required to exercise full control over the Work, including the construction means, methods, techniques, sequences, procedures, safety precautions and programs, and coordination of all portions of the Work with that of all other contractors and Subcontractors, except to the extent that the Contract Documents provide other specific instructions. Contractor's responsibilities extend to any plan, method or sequence suggested, but not required by City or specified in the Contract Documents. From the date of commencement of the Work until either the date on which City formally accepts the Project or the effective date of termination of the Contract, whichever is later, Contractor bears all risks of injury or damage to the Work and the materials and equipment delivered to any Worksite, by any cause including fire, earthquake, wind, weather, vandalism or theft.

(C) **Project Administration.** Contractor must provide sufficient and competent administration, staff, and skilled workforce necessary to perform and timely complete the Work in accordance with the Contract Documents. Before starting the Work, Contractor must designate in writing and provide complete contact information, including telephone numbers and email address, for the officer or employee in Contractor's organization who is to serve as Contractor's primary representative for the Project, and who has authority to act on Contractor's behalf. A Subcontractor may not serve as Contractor's primary representative.

(D) **On-Site Superintendent.** Contractor must, at all times during performance of the Work, provide a qualified and competent full-time superintendent acceptable to City, and assistants as necessary, who must be physically present at the Project site while any aspect of the Work is being performed. The superintendent must have full authority to act and communicate on behalf of Contractor, and Contractor will be bound by the

superintendent's communications to City. City's approval of the superintendent is required before the Work commences. If City is not satisfied with the superintendent's performance, City may request a qualified replacement of the superintendent. Failure to comply may result in temporary suspension of the Work, at Contractor's sole expense and with no extension of Contract Time, until an approved superintendent is physically present to supervise the Work. Contractor must provide written notice to City, as soon as practicable, before replacing the superintendent.

(E) **Standards.** Contractor must, at all times, ensure that the Work is performed in an efficient, skillful manner following best practices and in full compliance with the Contract Documents and Laws and applicable manufacturer's recommendations. Contractor has a material and ongoing obligation to provide true and complete information, to the best of its knowledge, with respect to all records, documents, or communications pertaining to the Project, including oral or written reports, statements, certifications, Change Order requests, or Claims.

(F) **Meetings.** Contractor, its project manager, superintendent and any primary Subcontractors requested by City, must attend a pre-construction conference, if requested by City, as well as weekly Project progress meetings scheduled with City. If applicable, Contractor may also be required to participate in coordination meetings with other parties relating to other work being performed on or near the Project site or in relation to the Project, including work or activities performed by City, other contractors, or other utility owners.

(G) **Construction Records.** Contractor will maintain up-to-date, thorough, legible, and dated daily job reports, which document all significant activity on the Project for each day that Work is performed on the Project. The daily report for each day must include the number of workers at the Project site; primary Work activities; major deliveries; problems encountered, including injuries, if any; weather and site conditions; and delays, if any. Contractor will take date and time-stamped photographs to document general progress of the Project, including site conditions prior to construction activities, before and after photographs at offset trench laterals, existing improvements and utilities, damage and restoration. Contractor will maintain copies of all subcontracts, Project-related correspondence with Subcontractors, and records of meetings with Subcontractors. Upon request by the City, Contractor will permit review of and/or provide copies of any of these construction records.

(H) **Responsible Party.** Contractor is solely responsible to City for the acts or omissions of any Subcontractors, or any other party or parties performing portions of the Work or providing equipment, materials or services for or on behalf of Contractor or the Subcontractors. Upon City's written request, Contractor must promptly and permanently remove from the Project, at no cost to City, any employee or Subcontractor or employee of a Subcontractor who the Engineer has determined to be incompetent, intemperate or disorderly, or who has failed or refused to perform the Work as required under the Contract Documents.

(I) **Correction of Defects.** Contractor must promptly correct, at Contractor's sole expense, any Work that is determined by City to be deficient or defective in any way, including workmanship, materials, parts or equipment. Workmanship, materials, parts or equipment that do not conform to the requirements under the Plans, Specifications and every other Contract Document, as determined by City, will be considered defective and subject to rejection. Contractor must also promptly correct, at Contractor's sole expense, any Work performed beyond the lines and grades shown on the Plans or established by City, and any Extra Work performed without City's prior written approval. If Contractor fails to correct or to take reasonable steps toward correcting defective Work within five days following notice from City, or within the time specified in City's notice to correct, City

may elect to have the defective Work corrected by its own forces or by a third party, in which case the cost of correction will be deducted from the Contract Price. If City elects to correct defective Work due to Contractor's failure or refusal to do so, City or its agents will have the right to take possession of and use any equipment, supplies, or materials available at the Project site or any Worksite on City property, in order to effectuate the correction, at no extra cost to City. Contractor's warranty obligations under Section 11.2, Warranty, will not be waived nor limited by City's actions to correct defective Work under these circumstances. Alternatively, City may elect to retain defective Work, and deduct the difference in value, as determined by the Engineer, from payments otherwise due to Contractor. This paragraph applies to any defective Work performed by Contractor during the one-year warranty period under Section 11.2.

(J) **Contractor's Records.** Contractor must maintain all of its records relating to the Project in any form, including paper documents, photos, videos, electronic records, approved samples, and the construction records required pursuant to paragraph (G), above. Project records subject to this provision include complete Project cost records and records relating to preparation of Contractor's bid, including estimates, take-offs, and price quotes or bids.

(1) Contractor's cost records must include all supporting documentation, including original receipts, invoices, and payroll records, evidencing its direct costs to perform the Work, including, but not limited to, costs for labor, materials and equipment. Each cost record should include, at a minimum, a description of the expenditure with references to the applicable requirements of the Contract Documents, the amount actually paid, the date of payment, and whether the expenditure is part of the original Contract Price, related to an executed Change Order, or otherwise categorized by Contractor as Extra Work. Contractor's failure to comply with this provision as to any claimed cost operates as a waiver of any rights to recover the claimed cost.

(2) Contractor must continue to maintain its Project-related records in an organized manner for a period of five years after City's acceptance of the Project or following Contract termination, whichever occurs first. Subject to prior notice to Contractor, City is entitled to inspect or audit any of Contractor's records relating to the Project during Contractor's normal business hours. The record-keeping requirements set forth in this subsection 2.2(J) will survive expiration or termination of the Contract.

(K) **Copies of Project Documents.** Contractor and its Subcontractors must keep copies, at the Project site, of all Work-related documents, including the Contract, permit(s), Plans, Specifications, Addenda, Contract amendments, Change Orders, RFIs and RFI responses, Shop Drawings, as-built drawings, schedules, daily records, testing and inspection reports or results, and any related written interpretations. These documents must be available to City for reference at all times during construction of the Project.

2.3 Subcontractors.

(A) **General.** All Work which is not performed by Contractor with its own forces must be performed by Subcontractors. City reserves the right to approve or reject any and all Subcontractors proposed to perform the Work, for reasons including the subcontractor's poor reputation, lack of relevant experience, financial instability, and lack of technical ability or adequate trained workforce. Each Subcontractor must obtain a City business license before performing any Work.

(B) **Contractual Obligations.** Contractor must require each Subcontractor to comply with the provisions of the Contract Documents as they apply to the Subcontractor's portion(s) of the Work, including the generally applicable terms of the Contract Documents, and to likewise bind their subcontractors. Contractor will provide that the rights that each Subcontractor may have against any manufacturer or supplier for breach of warranty or guarantee relating to items provided by the Subcontractor for the Project, will be assigned to City. Nothing in these Contract Documents creates a contractual relationship between a Subcontractor and City, but City is deemed to be a third-party beneficiary of the contract between Contractor and each Subcontractor.

(C) **Termination.** If the Contract is terminated, each Subcontractor's agreement must be assigned by Contractor to City, subject to the prior rights of any surety, but only if and to the extent that City accepts, in writing, the assignment by written notification, and assumes all rights and obligations of Contractor pursuant to each such subcontract agreement.

(D) **Substitution of Subcontractor.** If Contractor requests substitution of a listed Subcontractor under Public Contract Code § 4107, Contractor is solely responsible for all costs City incurs in responding to the request, including legal fees and costs to conduct a hearing, and any increased subcontract cost to perform the Work that was to be performed by the listed Subcontractor. If City determines that a Subcontractor is unacceptable to City based on the Subcontractor's failure to satisfactorily perform its Work, or for any of the grounds for substitution listed in Public Contract Code § 4107(a), City may request removal of the Subcontractor from the Project. Upon receipt of a written request from City to remove a Subcontractor pursuant to this paragraph, Contractor will immediately remove the Subcontractor from the Project and, at no further cost to City, will either (1) self-perform the remaining Work to the extent that Contractor is duly licensed and qualified to do so, or (2) substitute a Subcontractor that is acceptable to City, in compliance with Public Contract Code § 4107, as applicable.

2.4 Coordination of Work.

(A) **Concurrent Work.** City reserves the right to perform, have performed, or permit performance of other work on or adjacent to the Project site while the Work is being performed for the Project. Contractor is responsible for coordinating its Work with other work being performed on or adjacent to the Project site, including by any utility companies or agencies, and must avoid hindering, delaying, or interfering with the work of other contractors, individuals, or entities, and must ensure safe and reasonable site access and use as required or authorized by City. To the full extent permitted by law, Contractor must hold harmless and indemnify City against any and all claims arising from or related to Contractor's avoidable, negligent, or willful hindrance of, delay to, or interference with the work of any utility company or agency or another contractor or subcontractor.

(B) **Coordination.** If Contractor's Work will connect or interface with work performed by others, Contractor is responsible for independently measuring and visually inspecting such work to ensure a correct connection and interface. Contractor is responsible for any failure by Contractor or its Subcontractors to confirm measurements before proceeding with connecting Work. Before proceeding with any portion of the Work affected by the construction or operations of others, Contractor must give the Project Manager prompt written notification of any defects Contractor discovers which will prevent the proper execution of the Work. Failure to give notice of any known or reasonably discoverable defects will be deemed acknowledgement by Contractor that the work of others is not defective and will not prevent the proper execution of the Work. Contractor must also promptly notify City if work performed by others, including work or activities performed by City's own forces, is operating to hinder, delay, or interfere with Contractor's timely

performance of the Work. City reserves the right to backcharge Contractor for any additional costs incurred due to Contractor's failure to comply with the requirements in this Section 2.4.

2.5 Submittals. Unless otherwise specified, Contractor must submit to the Engineer for review and acceptance, all schedules, Shop Drawings, samples, product data, and similar submittals required by the Contract Documents, or upon request by the Engineer. Unless otherwise specified, all submittals, including Requests for Information, are subject to the general provisions of this Section, as well as specific submittal requirements that may be included elsewhere in the Contract Documents, including the Special Conditions or Specifications. The Engineer may require submission of a submittal schedule at or before a pre-construction conference, as may be specified in the Notice to Proceed.

(A) **General.** Contractor is responsible for ensuring that its submittals are accurate and conform to the Contract Documents.

(B) **Time and Manner of Submission.** Contractor must ensure that its submittals are prepared and delivered in a manner consistent with the current City-accepted schedule for the Work and within the applicable time specified in the Contract Documents, or if no time is specified, in such time and sequence so as not to delay the performance of the Work or completion of the Project.

(C) **Required Contents.** Each submittal must include the Project name and contract number, Contractor's name and address, the name and address of any Subcontractor or supplier involved with the submittal, the date, and references to applicable Specification section(s) and/or drawing and detail number(s).

(D) **Required Corrections.** If corrections are required, Contractor must promptly make and submit any required corrections as specified in full conformance with the requirements of this Section, or other requirements that apply to that submittal.

(E) **Effect of Review and Acceptance.** Review and acceptance of a submittal by City will not relieve Contractor from complying with the requirements of the Contract Documents. Contractor is responsible for any errors in any submittal, and review or acceptance of a submittal by City is not an assumption of risk or liability by City.

(F) **Enforcement.** Any Work performed or any material furnished, installed, fabricated or used without City's prior acceptance of a required submittal is performed or provided at Contractor's risk, and Contractor may be required to bear the costs incident thereto, including the cost of removing and replacing such Work, repairs to other affected portions of the Work or material, and the cost of additional time or services required of City, including costs for the Design Professional, Project Manager, or Inspector.

(G) **Excessive RFIs.** A RFI will be considered excessive or unnecessary if City determines that the explanation or response to the RFI is clearly and unambiguously discernable from the Contract Documents. City's costs to review and respond to excessive or unnecessary RFIs may be deducted from payments otherwise due to Contractor.

2.6 Shop Drawings. When Shop Drawings are required by the Specifications or requested by the Engineer, they must be prepared according to best practices at Contractor's expense. The Shop Drawings must be of a size and scale to clearly show all necessary details. Unless otherwise specified by City, Shop Drawings must be provided to the Engineer for review and acceptance at least 30 days before the Work will be performed. If City requires changes, the corrected Shop Drawings must be resubmitted to the Engineer for review within the time specified by the Engineer. For all Project components

requiring Shop Drawings, Contractor will not furnish materials or perform any Work until the Shop Drawings for those components are accepted by City. Contractor is responsible for any errors or omissions in the Shop Drawings, shop fits and field corrections; any deviations from the Contract Documents; and for the results obtained by the use of Shop Drawings. Acceptance of Shop Drawings by City does not relieve Contractor of Contractor's responsibility.

- 2.7 Access to Work.** Contractor must afford prompt and safe access to any Worksite by City and its employees, agents, or consultants authorized by City; and upon request by City, Contractor must promptly arrange for City representatives to visit or inspect manufacturing sites or fabrication facilities for items to be incorporated into the Work.
- 2.8 Personnel.** Contractor and its Subcontractors must employ only competent and skillful personnel to perform the Work. Contractor and its Subcontractor's supervisors, security or safety personnel, and employees who have unescorted access to the Project site must possess proficiency in English sufficient to read, understand, receive, and implement oral or written communications or instructions relating to their respective job functions, including safety and security requirements. Upon written notification from the Engineer, Contractor and its Subcontractors must immediately discharge any personnel who are incompetent, disorderly, disruptive, threatening, abusive, or profane, or otherwise refuse or fail to comply with the requirements of the Contract Documents or Laws, including Laws pertaining to health and safety. Any such discharged personnel may not be re-employed or permitted on the Project in any capacity without City's prior written consent.

Article 3 - Contract Documents

3.1 Interpretation of Contract Documents.

(A) **Plans and Specifications.** The Plans and Specifications included in the Contract Documents are complementary. If Work is shown on one but not on the other, Contractor must perform the Work as though fully described on both, consistent with the Contract Documents and reasonably inferable from them as being necessary to produce the indicated results. The Plans and Specifications are deemed to include and require everything necessary and reasonably incidental to completion of the Work, whether or not particularly mentioned or shown. Contractor must perform all Work and services and supply all things reasonably related to and inferable from the Contract Documents. In the event of a conflict between the Plans and Specifications, the Specifications will control, unless the drawing(s) at issue are dated later than the Specification(s) at issue. Detailed drawings take precedence over general drawings, and large-scale drawings take precedence over smaller scale drawings. Any arrangement or division of the Plans and Specifications into sections is for convenience and is not intended to limit the Work required by separate trades. A conclusion presented in the Plans or Specifications is only a recommendation. Actual locations and depths must be determined by Contractor's field investigation. Contractor may request access to underlying or background information in City's possession that is necessary for Contractor to form its own conclusions.

(B) **Duty to Notify and Seek Direction.** If Contractor becomes aware of a changed condition in the Project, or of any ambiguity, conflict, inconsistency, discrepancy, omission, or error in the Contract Documents, including the Plans or Specifications, Contractor must promptly submit a Request for Information to the Engineer and wait for a response from City before proceeding further with the related Work. The RFI must notify City of the issue and request clarification, interpretation or direction. The Engineer's clarification, interpretation or direction will be final and binding on Contractor. If Contractor proceeds with the related Work before obtaining City's response, Contractor will be responsible for any resulting costs, including the cost of correcting any incorrect or

defective Work that results. Timely submission of a clear and complete RFI is essential to avoiding delay. Delay resulting from Contractor's failure to submit a timely and complete RFI to the Engineer is Non-Excusable Delay. If Contractor believes that City's response to an RFI justifies a change to the Contract Price or Contract Time, Contractor must perform the Work as directed, but may submit a timely Change Order request in accordance with the Contract Documents. (See Article 5 and 6.)

(C) **Figures and Dimensions.** Figures control over scaled dimensions.

(D) **Technical or Trade Terms.** Any terms that have well-known technical or trade meanings will be interpreted in accordance with those meanings, unless otherwise specifically defined in the Contract Documents.

(E) **Measurements.** Contractor must verify all relevant measurements in the Contract Documents and at the Project site before ordering any material or performing any Work, and will be responsible for the correctness of those measurements or for costs that could have been avoided by independently verifying measurements.

(F) **Compliance with Laws.** The Contract Documents are intended to comply with Laws and will be interpreted to comply with Laws.

3.2 Order of Precedence. Information included in one Contract Document but not in another will not be considered a conflict or inconsistency. Unless otherwise specified in the Special Conditions, in case of any conflict or inconsistency among the Contract Documents, the following order of precedence will apply, beginning from highest to lowest, with the most recent version taking precedent over an earlier version:

- (A) Change Orders;
- (B) Addenda;
- (C) Contract;
- (D) Notice to Proceed;
- (E) Attachment B – Federal Contract Requirements (only if used);
- (F) Special Conditions;
- (G) General Conditions;
- (H) Payment and Performance Bonds;
- (I) Specifications;
- (J) Plans;
- (K) Notice of Potential Award;
- (L) Notice Inviting Bids;
- (M) Attachment A – Federal Bidding Requirements (only if used);
- (N) Instructions to Bidders;
- (O) Contractor's Bid Proposal and attachments;
- (P) the City's standard specifications, as applicable; and
- (Q) Any generic documents prepared by and on behalf of a third party, that were not prepared specifically for this Project, such as the Caltrans Standard Specifications or Caltrans Special Provisions.

3.3 Caltrans Standard Specifications. Any reference to or incorporation of the Standard Specifications of the State of California, Department of Transportation ("Caltrans"), including "Standard Specifications," "Caltrans Specifications," "State Specifications," or "CSS," means the most current edition of Caltrans' Standard Specifications, unless otherwise specified ("Caltrans Standard Specifications"), including the most current amendments as of the date that Contractor's bid was submitted for this Project. The following provisions apply to use of or reference to the Caltrans Standard Specifications or Special Provisions:

(A) **Limitations.** The “General Provisions” of the Caltrans Standard Specifications, i.e., sections 1 through 9, do not apply to these Contract Documents with the exception of any specific provisions, if any, which are expressly stated to apply to these Contract Documents.

(B) **Conflicts or Inconsistencies.** If there is a conflict or inconsistency between any provision in the Caltrans Standard Specifications or Special Provisions and a provision of these Contract Documents, as determined by City, the provision in the Contract Documents will govern.

(C) **Meanings.** Terms used in the Caltrans Standard Specifications or Special Provisions are to be interpreted as follows:

(1) Any reference to the “Engineer” is deemed to mean the City Engineer.

(2) Any reference to the “Special Provisions” is deemed to mean the Special Conditions, unless the Caltrans Special Provisions are expressly included in the Contract Documents listed in Section 2 of the Contract.

(3) Any reference to the “Department” or “State” is deemed to mean City.

3.4 For Reference Only. Contractor is responsible for the careful review of any document, study, or report provided by City or appended to the Contract Documents solely for informational purposes and identified as “For Reference Only.” Nothing in any document, study, or report so appended and identified is intended to supplement, alter, or void any provision of the Contract Documents. Contractor is advised that City or its representatives may be guided by information or recommendations included in such reference documents, particularly when making determinations as to the acceptability of proposed materials, methods, or changes in the Work. Any record drawings or similar final or accepted drawings or maps that are not part of the Contract Documents are deemed to be For Reference Only. The provisions of the Contract Documents are not modified by any perceived or actual conflict with provisions in any document that is provided For Reference Only.

3.5 Current Versions. Unless otherwise specified by City, any reference to standard specifications, technical specifications, or any City or state codes or regulations means the latest specification, code or regulation in effect at the time the Contract is signed.

3.6 Conformed Copies. If City prepares a conformed set of the Contract Documents following award of the Contract, it will provide Contractor with two hard copy (paper) sets and one copy of the electronic file in PDF format. It is Contractor’s responsibility to ensure that all Subcontractors, including fabricators, are provided with the conformed set of the Contract Documents at Contractor’s sole expense.

3.7 Ownership. No portion of the Contract Documents may be used for any purpose other than construction of the Project, without prior written consent from City. Contractor is deemed to have conveyed the copyright in any designs, drawings, specifications, Shop Drawings, or other documents (in paper or electronic form) developed by Contractor for the Project, and City will retain all rights to such works, including the right to possession.

Article 4 - Bonds, Indemnity, and Insurance

4.1 Payment and Performance Bonds. Within ten days following issuance of the Notice of Potential Award, Contractor is required to provide a payment bond and a performance bond, each in the penal sum of not less than 100% of the Contract Price, and each

executed by Contractor and its surety using the bond forms included with the Contract Documents.

(A) **Surety.** Each bond must be issued and executed by a surety admitted in California. If an issuing surety cancels the bond or becomes insolvent, within seven days following written notice from City, Contractor must substitute a surety acceptable to City. If Contractor fails to substitute an acceptable surety within the specified time, City may, at its sole discretion, withhold payment from Contractor until the surety is replaced to City's satisfaction, or terminate the Contract for default.

(B) **Supplemental Bonds for Increase in Contract Price.** If the Contract Price increases during construction by five percent or more over the original Contract Price, Contractor must provide supplemental or replacement bonds within ten days of written notice from City pursuant to this Section, covering 100% of the increased Contract Price and using the bond forms included with the Contract Documents.

4.2 Indemnity. To the fullest extent permitted by law, Contractor must indemnify, defend, and hold harmless City, its Council, officers, officials, employees, agents, volunteers, and consultants (individually, an "Indemnitee," and collectively the "Indemnitees") from and against any and all liability, loss, damage, claims, causes of action, demands, charges, fines, costs, and expenses (including, without limitation, attorney fees, expert witness fees, paralegal fees, and fees and costs of litigation or arbitration) (collectively, "Liability") of every nature arising out of or in connection with the acts or omissions of Contractor, its employees, Subcontractors, representatives, or agents, in bidding or performing the Work or in failing to comply with any obligation of Contractor under the Contract, except such Liability caused by the active negligence, sole negligence, or willful misconduct of an Indemnitee. This indemnity requirement applies to any Liability arising from alleged defects in the content or manner of submission of Contractor's bid for the Contract. Contractor's failure or refusal to timely accept a tender of defense pursuant to this Contract will be deemed a material breach of the Contract. City will timely notify Contractor upon receipt of any third-party claim relating to the Contract, as required by Public Contract Code § 9201. Contractor waives any right to express or implied indemnity against any Indemnitee. Contractor's indemnity obligations under this Contract will survive the expiration or any early termination of the Contract.

4.3 Insurance. No later than ten days following issuance of the Notice of Potential Award, Contractor must procure and provide proof of the insurance coverage required by this Section in the form of certificates and endorsements acceptable to City. The required insurance must cover the activities of Contractor and its Subcontractors relating to or arising from the performance of the Work, and must remain in full force and effect at all times during the period covered by the Contract, through the date of City's acceptance of the Project. All required insurance must be issued by a company licensed to do business in the State of California, and each such insurer must have an A.M. Best's financial strength rating of "A" or better and a financial size rating of "VIII" or better. If Contractor fails to provide any of the required coverage in full compliance with the requirements of the Contract Documents, City may, at its sole discretion, purchase such coverage at Contractor's expense and deduct the cost from payments due to Contractor, or terminate the Contract for default. The procurement of the required insurance will not be construed to limit Contractor's liability under this Contract or to fulfill Contractor's indemnification obligations under this Contract.

(A) **Policies and Limits.** The following insurance policies and limits are required for this Contract, unless otherwise specified in the Special Conditions:

(1) *Commercial General Liability ("CGL") Insurance:* The CGL insurance policy must be issued on an occurrence basis, written on a comprehensive general

liability form, and must include coverage for liability arising from Contractor's or its Subcontractor's acts or omissions in the performance of the Work, including contractor's protected coverage, contractual liability, products and completed operations, and broad form property damage, with limits of at least \$2,000,000 per occurrence and at least \$4,000,000 general aggregate. The CGL insurance coverage may be arranged under a single policy for the full limits required or by a combination of underlying policies with the balance provided by excess or umbrella policies, provided each such policy complies with the requirements set forth in this Section, including required endorsements.

(2) *Automobile Liability Insurance:* The automobile liability insurance policy must provide coverage of at least \$2,000,000 combined single-limit per accident for bodily injury, death, or property damage, including hired and non-owned auto liability.

(3) *Workers' Compensation Insurance and Employer's Liability:* The workers' compensation and employer's liability insurance policy must comply with the requirements of the California Labor Code, providing coverage of at least \$1,000,000 or as otherwise required by the statute. If Contractor is self-insured, Contractor must provide its Certificate of Permission to Self-Insure, duly authorized by the DIR.

(4) *Pollution Liability Insurance:* The pollution liability insurance policy must be issued on an occurrence basis, providing coverage of at least \$2,000,000 for all loss arising out of claims for bodily injury, death, property damage, or environmental damage caused by pollution conditions resulting from the Work.

(5) *Builder's Risk Insurance:* The builder's risk insurance policy must be issued on an occurrence basis, for all-risk or "all perils" coverage on a 100% completed value basis on the insurable portion of the Project for the benefit of City.

(B) **Notice.** Each certificate of insurance must state that the coverage afforded by the policy or policies will not be reduced, cancelled or allowed to expire without at least 30 days written notice to City, unless due to non-payment of premiums, in which case ten days written notice must be made to City.

(C) **Waiver of Subrogation.** Each required policy must include an endorsement providing that the carrier will waive any right of subrogation it may have against City.

(D) **Required Endorsements.** The CGL policy, automobile liability policy, pollution liability policy, and builder's risk policy must include the following specific endorsements:

(1) The City, including its Council, officials, officers, employees, agents, volunteers and consultants (collectively, "Additional Insured") must be named as an additional insured for all liability arising out of the operations by or on behalf of the named insured, and the policy must protect the Additional Insured against any and all liability for personal injury, death or property damage or destruction arising directly or indirectly in the performance of the Contract. The additional insured endorsement must be provided using ISO form CG 20 10 11 85 or an equivalent form approved by the City.

(2) The inclusion of more than one insured will not operate to impair the rights of one insured against another, and the coverages afforded will apply as though separate policies have been issued to each insured.

(3) The insurance provided by Contractor is primary and no insurance held or owned by any Additional Insured may be called upon to contribute to a loss.

(4) This policy does not exclude explosion, collapse, underground excavation hazard, or removal of lateral support.

(E) **Contractor's Responsibilities.** This Section 4.3 establishes the minimum requirements for Contractor's insurance coverage in relation to this Project, but is not intended to limit Contractor's ability to procure additional or greater coverage. Contractor is responsible for its own risk assessment and needs and is encouraged to consult its insurance provider to determine what coverage it may wish to carry beyond the minimum requirements of this Section. Contractor is solely responsible for the cost of its insurance coverage, including premium payments, deductibles, or self-insured retentions, and no Additional Insured will be responsible or liable for any of the cost of Contractor's insurance coverage.

(F) **Deductibles and Self-Insured Retentions.** Any deductibles or self-insured retentions that apply to the required insurance (collectively, "deductibles") in excess of \$100,000 are subject to approval by the City's Risk Manager, acting in his or her sole discretion, and must be declared by Contractor when it submits its certificates of insurance and endorsements pursuant to this Section 4.3. If the City's Risk Manager determines that the deductibles are unacceptably high, at City's option, Contractor must either reduce or eliminate the deductibles as they apply to City and all required Additional Insured; or must provide a financial guarantee, to City's satisfaction, guaranteeing payment of losses and related investigation, claim administration, and legal expenses.

(G) **Subcontractors.** Contractor must ensure that each Subcontractor is required to maintain the same insurance coverage required under this Section 4.3, with respect to its performance of Work on the Project, including those requirements related to the Additional Insureds and waiver of subrogation, but excluding pollution liability or builder's risk insurance unless otherwise specified in the Special Conditions. A Subcontractor may be eligible for reduced insurance coverage or limits, but only to the extent approved in writing in advance by the City's Risk Manager. Contractor must confirm that each Subcontractor has complied with these insurance requirements before the Subcontractor is permitted to begin Work on the Project. Upon request by the City, Contractor must provide certificates and endorsements submitted by each Subcontractor to prove compliance with this requirement. The insurance requirements for Subcontractors do not replace or limit the Contractor's insurance obligations.

Article 5 - Contract Time

5.1 Time is of the Essence. Time is of the essence in Contractor's performance and completion of the Work, and Contractor must diligently prosecute the Work and complete it within the Contract Time.

(A) **General.** Contractor must commence the Work on the date indicated in the Notice to Proceed and must fully complete the Work in strict compliance with all requirements of the Contract Documents and within the Contract Time. Contractor may not begin performing the Work before the date specified in the Notice to Proceed.

(B) **Authorization.** Contractor is not entitled to compensation or credit for any Work performed before the date specified in the Notice to Proceed, with the exception of any schedules, submittals, or other requirements, if any, that must be provided or performed before issuance of the Notice to Proceed.

(C) **Rate of Progress.** Contractor and its Subcontractors must, at all times, provide workers, materials, and equipment sufficient to maintain the rate of progress necessary to ensure full completion of the Work within the Contract Time. If City determines that Contractor is failing to prosecute the Work at a sufficient rate of progress, City may, in its sole discretion, direct Contractor to provide additional workers, materials, or equipment, or to work additional hours or days without additional cost to City, in order to achieve a rate of progress satisfactory to City. If Contractor fails to comply with City's directive in this regard, City may, at Contractor's expense, separately contract for additional workers, materials, or equipment or use City's own forces to achieve the necessary rate of progress. Alternatively, City may terminate the Contract based on Contractor's default.

5.2 Schedule Requirements. Contractor must prepare all schedules using standard, commercial scheduling software acceptable to the Engineer, and must provide the schedules in electronic and paper form as requested by the Engineer. In addition to the general scheduling requirements set forth below, Contractor must also comply with any scheduling requirements included in the Special Conditions or in the Technical Specifications.

(A) **Baseline (As-Planned) Schedule.** Within ten calendar days following City's issuance of the Notice to Proceed (or as otherwise specified in the Notice to Proceed), Contractor must submit to City for review and acceptance a baseline (as-planned) schedule using critical path methodology showing in detail how Contractor plans to perform and fully complete the Work within the Contract Time, including labor, equipment, materials and fabricated items. The baseline schedule must show the order of the major items of Work and the dates of start and completion of each item, including when the materials and equipment will be procured. The schedule must also include the work of all trades, reflecting anticipated labor or crew hours and equipment loading for the construction activities, and must be sufficiently comprehensive and detailed to enable progress to be monitored on a day-by-day basis. For each activity, the baseline schedule must be dated, provided in the format specified in the Contract Documents or as required by City, and must include, at a minimum, a description of the activity, the start and completion dates of the activity, and the duration of the activity.

(1) **Specialized Materials Ordering.** Within five calendar days following issuance of the Notice to Proceed, Contractor must order any specialized material or equipment for the Work that is not readily available from material suppliers. Contractor must also retain documentation of the purchase order date(s).

(B) **City's Review of Schedules.** City will review and may note exceptions to the baseline schedule, and to the progress schedules submitted as required below, to assure completion of the Work within the Contract Time. Contractor is solely responsible for resolving any exceptions noted in a schedule and, within seven days, must correct the schedule to address the exceptions. City's review or acceptance of Contractor's schedules will not operate to waive or limit Contractor's duty to complete the Project within the Contract Time, nor to waive or limit City's right to assess liquidated damages for Contractor's unexcused failure to do so.

(C) **Progress Schedules.** After City accepts the final baseline schedule with no exceptions, Contractor must submit an updated progress schedule and three-week look-ahead schedule, in the format specified by City, for review and acceptance with each application for a progress payment, or when otherwise specified by City, until completion of the Work. The updated progress schedule must: show how the actual progress of the Work as constructed to date compares to the baseline schedule; reflect any proposed changes in the construction schedule or method of operations, including to achieve Project milestones within the Contract Time; and identify any actual or potential impacts

to the critical path. Contractor must also submit periodic reports to City of any changes in the projected material or equipment delivery dates for the Project.

(1) *Float*. The progress schedule must show early and late completion dates for each task. The number of days between those dates will be designated as the "float." Any float belongs to the Project and may be allocated by the Engineer to best serve timely completion of the Project.

(2) *Failure to Submit Schedule*. Reliable, up-to-date schedules are essential to efficient and cost-effective administration of the Project and timely completion. If Contractor fails to submit a schedule within the time periods specified in this Section, or submits a schedule to which City has noted exceptions that are not corrected, City may withhold up to ten percent from payment(s) otherwise due to Contractor until the exceptions are resolved, the schedule is corrected and resubmitted, and City has accepted the schedule. In addition, Contractor's failure to comply with the schedule requirements in this Section 5.2 will be deemed a material default and a waiver of any claims for Excusable Delay or loss of productivity arising during any period when Contractor is out of compliance, subject only to the limits of Public Contract Code § 7102.

(D) **Recovery Schedule**. If City determines that the Work is more than one week behind schedule, within seven days following written notice of such determination, Contractor must submit a recovery schedule, showing how Contractor intends to perform and complete the Work within the Contract Time, based on actual progress to date.

(E) **Effect of Acceptance**. Contractor and its Subcontractors must perform the Work in accordance with the most current City-accepted schedule unless otherwise directed by City. City's acceptance of a schedule does not operate to extend the time for completion of the Work or any component of the Work, and will not affect City's right to assess liquidated damages for Contractor's unexcused delay in completing the Work within the Contract Time.

(F) **Posting**. Contractor must at all times prominently post a copy of the most current City-accepted progress or recovery schedule in its on-site office.

(G) **Reservation of Rights**. City reserves the right to direct the sequence in which the Work must be performed or to make changes in the sequence of the Work in order to facilitate the performance of work by City or others, or to facilitate City's use of its property. The Contract Time or Contract Price may be adjusted to the extent such changes in sequence actually increase or decrease Contractor's time or cost to perform the Work.

(H) **Authorized Working Days and Times**. Contractor is limited to working Monday through Friday, excluding holidays, during City's normal business hours, except as provided in the Special Conditions or as authorized in writing by City. City reserves the right to charge Contractor for additional costs incurred by City due to Work performed on days or during hours not expressly authorized in the Contract Documents, including reimbursement of costs incurred for inspection, testing, and construction management services.

5.3 Delay and Extensions of Contract Time.

(A) **Notice of Delay**. If Contractor becomes aware of any actual or potential delay affecting the critical path, Contractor must promptly notify the Engineer in writing, regardless of the nature or cause of the delay, so that City has a reasonable opportunity to mitigate or avoid the delay.

(B) **Excusable Delay.** The Contract Time may be extended if Contractor encounters "Excusable Delay," which is an unavoidable delay in completing the Work within the Contract Time due to causes completely beyond Contractor's control, and which Contractor could not have avoided or mitigated through reasonable care, planning, foresight, and diligence, provided that Contractor is otherwise fully performing its obligations under the Contract Documents. Grounds for Excusable Delay may include fire, natural disasters including earthquake or unusually severe weather, acts of terror or vandalism, epidemic, unforeseeable adverse government actions, unforeseeable actions of third parties, encountering unforeseeable hazardous materials, unforeseeable site conditions, or suspension for convenience under Article 13. The Contract Time will not be extended based on circumstances which will not unavoidably delay completing the Work within the Contract Time based on critical path analysis.

(C) **Weather Delays.** A "Weather Delay Day" is a Working Day during which Contractor and its forces, including Subcontractors, are unable to perform more than 40% of the critical path Work scheduled for that day due to adverse weather conditions which impair the ability to safely or effectively perform the scheduled critical path Work that day. Adverse weather conditions may include rain, saturated soil, and Project site clean-up required due to adverse weather. Determination of what constitutes critical path Work scheduled for that day will be based on the most current, City-approved schedule. Contractor will be entitled to a non-compensable extension of the Contract Time for each Weather Delay Day in excess of the normal Weather Delay Days within a given month as determined by reliable records, including monthly rainfall averages, for the preceding ten years (or as otherwise specified in the Special Conditions or Specifications).

(1) Contractor must fully comply with the applicable procedures in Articles 5 and 6 of the General Conditions regarding requests to modify the Contract Time.

(2) Contractor will not be entitled to an extension of time for a Weather Delay Day to the extent Contractor is responsible for concurrent delay on that day.

(3) Contractor must take reasonable steps to mitigate the consequences of Weather Delay Days, including prudent workforce management and protecting the Work, Project Site, materials, and equipment.

(D) **Non-Excusable Delay.** Delay which Contractor could have avoided or mitigated through reasonable care, planning, foresight and diligence is "Non-Excusable Delay." Contractor is not entitled to an extension of Contract Time or any compensation for Non-Excusable Delay, or for Excusable Delay that is concurrent with Non-Excusable Delay. Non-Excusable Delay includes delay caused by:

(1) weather conditions which are normal for the location of the Project, as determined by reliable records, including monthly rainfall averages, for the preceding ten years;

(2) Contractor's failure to order equipment and materials sufficiently in advance of the time needed for completion of the Work within the Contract Time;

(3) Contractor's failure to provide adequate notification to utility companies or agencies for connections or services necessary for completion of the Work within the Contract Time;

- (4) foreseeable conditions which Contractor could have ascertained from reasonably diligent inspection of the Project site or review of the Contract Documents or other information provided or available to Contractor;
- (5) Contractor's failure, refusal, or financial inability to perform the Work within the Contract Time, including insufficient funds to pay its Subcontractors or suppliers;
- (6) performance or non-performance by Contractor's Subcontractors or suppliers;
- (7) the time required to respond to excessive RFIs (see Section 2.5(G));
- (8) delayed submission of required submittals, or the time required for correction and resubmission of defective submittals;
- (9) time required for repair of, re-testing, or re-inspection of defective Work;
- (10) enforcement of Laws by City, or outside agencies with jurisdiction over the Work; or
- (11) City's exercise or enforcement of any of its rights or Contractor's duties pursuant to the Contract Documents, including correction of defective Work, extra inspections or testing due to non-compliance with Contract requirements, safety compliance, environmental compliance, or rejection and return of defective or deficient submittals.

(E) **Compensable Delay.** Pursuant to Public Contract Code § 7102, in addition to entitlement to an extension of Contract Time, Contractor is entitled to compensation for costs incurred due to delay caused solely by City, when that delay is unreasonable under the circumstances involved and not within the contemplation of the parties ("Compensable Delay"). Contractor is not entitled to an extension of Contract Time or recovery of costs for Compensable Delay that is concurrent with Non-Excusable Delay. Delay due to causes that are beyond the control of either City or Contractor, including Weather Delay Days, discovery of Historic or Archeological Items pursuant to Section 7.18, or the actions or inactions of third parties or other agencies, is not Compensable Delay, and will only entitle Contractor to an extension of time commensurate with the time lost due to such delay.

(F) **Recoverable Costs.** Contractor is not entitled to compensation for Excusable Delay unless it is Compensable Delay, as defined above. Contractor is entitled to recover only the actual, direct, reasonable, and substantiated costs ("Recoverable Costs") for each working day that the Compensable Delay prevents Contractor from proceeding with more than 50% of the critical path Work scheduled for that day, based on the most recent progress schedule accepted by City. Recoverable Costs will not include home office overhead or lost profit.

(G) **Request for Extension of Contract Time or Recoverable Costs.** A request for an extension of Contract Time or any associated Recoverable Costs must be submitted in writing to City within ten calendar days of the date the delay is first encountered, even if the duration of the delay is not yet known at that time, or any entitlement to the Contract Time extension or to the Recoverable Costs will be deemed waived. In addition to complying with the requirements of this Article 5, the request must be submitted in compliance with the Change Order request procedures in Article 6 below. Strict compliance with these requirements is necessary to ensure that any delay or consequences of delay may be mitigated as soon as possible, and to facilitate cost-

efficient administration of the Project and timely performance of the Work. Any request for an extension of Contract Time or Recoverable Costs that does not strictly comply with all of the requirements of Article 5 and Article 6 will be deemed waived.

(1) *Required Contents.* The request must include a detailed description of the cause(s) of the delay and must also describe the measures that Contractor has taken to mitigate the delay and/or its effects, including efforts to mitigate the cost impact of the delay, such as by workforce management or by a change in sequencing. If the delay is still ongoing at the time the request is submitted, the request should also include Contractor's plan for continued mitigation of the delay or its effects.

(2) *Delay Days and Costs.* The request must specify the number of days of Excusable Delay claimed or provide a realistic estimate if the duration of the delay is not yet known. If Contractor believes it is entitled to Recoverable Costs for Compensable Delay, the request must specify the amount and basis for the Recoverable Costs that are claimed or provide a realistic estimate if the amount is not yet known. Any estimate of delay duration or cost must be updated in writing and submitted with all required supporting documentation as soon as the actual time and cost is known. The maximum extension of Contract Time will be the number of days, if any, by which an Excusable Delay or a Compensable Delay exceeds any concurrent Non-Excusable Delay. Contractor is entitled to an extension of Contract Time, or compensation for Recoverable Costs, only if, and only to the extent that, such delay will unavoidably delay Final Completion.

(3) *Supporting Documentation.* The request must also include any and all supporting documentation necessary to evidence the delay and its actual impacts, including scheduling and cost impacts with a time impact analysis using critical path methodology and demonstrating the unavoidable delay to Final Completion. The time impact analysis must be submitted in a form or format acceptable to City.

(4) *Burden of Proof.* Contractor has the burden of proving that: the delay was an Excusable or Compensable Delay, as defined above; Contractor has fully complied with its scheduling obligations in Section 5.2, Schedule Requirements; Contractor has made reasonable efforts to mitigate the delay and its schedule and cost impacts; the delay will unavoidably result in delaying Final Completion; and any Recoverable Costs claimed by Contractor were actually incurred and were reasonable under the circumstances.

(5) *Legal Compliance.* Nothing in this Section 5.3 is intended to require the waiver, alteration, or limitation of the applicability of Public Contract Code § 7102.

(6) *No Waiver.* Any grant of an extension of Contract Time, or compensation for Recoverable Costs due to Compensable Delay, will not operate as a waiver of City's right to assess liquidated damages for Non-Excusable Delay.

(7) *Dispute Resolution.* In the event of a dispute over entitlement to an extension of Contract Time or compensation for Recoverable Costs, Contractor may not stop Work pending resolution of the dispute, but must continue to comply with its duty to diligently prosecute the performance and timely completion of the Work. Contractor's sole recourse for an unresolved dispute based on City's rejection of a Change Order request for an extension of Contract Time or compensation for Recoverable Costs is to comply with the dispute resolution provisions set forth in Article 12 below.

5.4 Liquidated Damages. It is expressly understood that if Final Completion is not achieved within the Contract Time, City will suffer damages from the delay that are difficult to determine and accurately specify. Pursuant to Public Contract Code § 7203, if Contractor fails to achieve Final Completion within the Contract Time due to Contractor's Non-Excusable Delay, City will charge Contractor in the amount specified in the Contract for each calendar day that Final Completion is delayed beyond the Contract Time, as liquidated damages and not as a penalty. Any waiver of accrued liquidated damages, in whole or in part, is subject to approval of the City Council or its authorized delegee.

(A) **Liquidated Damages.** Liquidated damages will not be assessed for any Excusable or Compensable Delay, as set forth above.

(B) **Milestones.** Liquidated damages may also be separately assessed for failure to meet milestones specified elsewhere in the Contract Documents.

(C) **Setoff.** City is entitled to deduct the amount of liquidated damages assessed against any payments otherwise due to Contractor, including progress payments, Final Payment, or unreleased retention. If there are insufficient Contract funds remaining to cover the full amount of liquidated damages assessed, City is entitled to recover the balance from Contractor or its performance bond surety.

(D) **Occupancy or Use.** Occupancy or use of the Project in whole or in part prior to Final Completion does not constitute City's acceptance of the Project and will not operate as a waiver of City's right to assess liquidated damages for Contractor's Non-Excusable Delay in achieving Final Completion.

(E) **Other Remedies.** City's right to liquidated damages under this Section applies only to damages arising from Contractor's Non-Excusable Delay or failure to complete the Work within the Contract Time. City retains its right to pursue all other remedies under the Contract for other types of damage, including damage to property or persons, costs or diminution in value from defective materials or workmanship, costs to repair or complete the Work, or other liability caused by Contractor.

Article 6 - Contract Modification

6.1 Contract Modification. Subject to the limited exception set forth in subsection (D) below, any change in the Work or the Contract Documents, including the Contract Price or Contract Time, will not be a valid and binding change to the Contract unless it is formalized in a Change Order, including a "no-cost" Change Order or a unilateral Change Order. Changes in the Work pursuant to this Article 6 will not operate to release, limit, or abridge Contractor's warranty obligations pursuant to Article 11 or any obligations of Contractor's bond sureties.

(A) **City-Directed Changes.** City may direct changes in the scope or sequence of Work or the requirements of the Contract Documents, without invalidating the Contract. Such changes may include Extra Work as set forth in subsection (C) below, or deletion or modification of portions of the Work. Contractor must promptly comply with City-directed changes in the Work in accordance with the original Contract Documents, even if Contractor and City have not yet reached agreement as to adjustments to the Contract Price or Contract Time for the change in the Work or for the Extra Work. Contractor is not entitled to extra compensation for cost savings resulting from "value engineering" pursuant to Public Contract Code § 7101, except to the extent authorized in advance by City in writing, and subject to any applicable procedural requirements for submitting a proposal for value engineering cost savings.

(B) **Disputes.** In the event of a dispute over entitlement to or the amount of a change in Contract Time or a change in Contract Price related to a City-directed change in the Work, Contractor must perform the Work as directed and may not delay its Work or cease Work pending resolution of the dispute, but must continue to comply with its duty to diligently prosecute the performance and timely completion of the Work, including the Work in dispute. Likewise, in the event that City and Contractor dispute whether a portion or portions of the Work are already required by the Contract Documents or constitute Extra Work, or otherwise dispute the interpretation of any portion(s) of the Contract Documents, Contractor must perform the Work as directed and may not delay its Work or cease Work pending resolution of the dispute, but must continue to comply with its duty to diligently prosecute the performance and timely completion of the Work, including the Work in dispute, as directed by City. If Contractor refuses to perform the Work in dispute, City may, acting in its sole discretion, elect to delete the Work from the Contract and reduce the Contract Price accordingly, and self-perform the Work or direct that the Work be performed by others. Alternatively, City may elect to terminate the Contract for convenience or for cause. Contractor's sole recourse for an unresolved dispute related to changes in the Work or performance of any Extra Work is to comply with the dispute resolution provisions set forth in Article 12, below.

(C) **Extra Work.** City may direct Contractor to perform Extra Work related to the Project. Contractor must promptly perform any Extra Work as directed or authorized by City in accordance with the original Contract Documents, even if Contractor and City have not yet reached agreement on adjustments to the Contract Price or Contract Time for such Extra Work. If Contractor believes it is necessary to perform Extra Work due to changed conditions, Contractor must promptly notify the Engineer in writing, specifically identifying the Extra Work and the reason(s) the Contractor believes it is Extra Work. This notification requirement does not constitute a Change Order request pursuant to Section 6.2, below. Contractor must maintain detailed daily records that itemize the cost of each element of Extra Work, and sufficiently distinguish the direct cost of the Extra Work from the cost of other Work performed. For each day that Contractor performs Extra Work, or Work that Contractor contends is Extra Work, Contractor must submit no later than the following Working Day, a daily report of the Extra Work performed that day and the related costs, together with copies of certified payroll, invoices, and other documentation substantiating the costs ("Extra Work Report"). The Engineer will make any adjustments to Contractor's Extra Work Report(s) based on the Engineer's records of the Work. When an Extra Work Report(s) is agreed on and signed by both City and Contractor, the Extra Work Report(s) will become the basis for payment under a duly authorized and signed Change Order. Failure to submit the required documentation by close of business on the next Working Day is deemed a full and complete waiver for any change in the Contract Price or Contract Time for any Extra Work performed that day.

(D) **Minor Changes and RFIs.** Minor field changes, including RFI replies from City, that do not affect the Contract Price or Contract Time and that are approved by the Engineer acting within his or her scope of authority, do not require a Change Order. By executing an RFI reply from City, Contractor agrees that it will perform the Work as clarified therein, with no change to the Contract Price or Contract Time.

(E) **Remedy for Non-Compliance.** Contractor's failure to promptly comply with a City-directed change is deemed a material breach of the Contract, and in addition to all other remedies available to it, City may, at its sole discretion, hire another contractor or use its own forces to complete the disputed Work at Contractor's sole expense, and may deduct the cost from the Contract Price.

6.2 Contractor Change Order Requests. Contractor must submit a request or proposal for a change in the Work, compensation for Extra Work, or a change in the Contract Price or Contract Time as a written Change Order request or proposal.

(A) **Time for Submission.** Any request for a change in the Contract Price or the Contract Time must be submitted in writing to the Engineer within ten calendar days of the date that Contractor first encounters the circumstances, information or conditions giving rise to the Change Order request, even if the total amount of the requested change in the Contract Price or impact on the Contract Time is not yet known at that time. If City requests that Contractor propose the terms of a Change Order, unless otherwise specified in City's request, Contractor must provide the Engineer with a written proposal for the change in the Contract Price or Contract Time within five working days of receiving City's request, in a form satisfactory to the Engineer.

(B) **Required Contents.** Any Change Order request or proposal submitted by Contractor must include a complete breakdown of actual or estimated costs and credits, and must itemize labor, materials, equipment, taxes, insurance, subcontract amounts, and, if applicable, Extra Work Reports. Any estimated cost must be updated in writing as soon as the actual amount is known.

(C) **Required Documentation.** All claimed costs must be fully documented, and any related request for an extension of time or delay-related costs must be included at that time and in compliance with the requirements of Article 5 of the General Conditions. Upon request, Contractor must permit City to inspect its original and unaltered bidding records, subcontract agreements, subcontract change orders, purchase orders, invoices, or receipts associated with the claimed costs.

(D) **Required Form.** Contractor must use City's form(s) for submitting all Change Order requests or proposals, unless otherwise specified by City.

(E) **Certification.** All Change Order requests must be signed by Contractor and must include the following certification:

"The undersigned Contractor certifies under penalty of perjury that its statements and representations in this Change Order request are true and correct. Contractor warrants that this Change Order request is comprehensive and complete as to the Work or changes referenced herein, and agrees that any known or foreseeable costs, expenses, or time extension requests not included herein, are deemed waived."

6.3 Adjustments to Contract Price. The amount of any increase or decrease in the Contract Price will be determined based on one of the following methods listed below, in the order listed with unit pricing taking precedence over the other methods. Markup applies only to City-authorized time and material Work, and does not apply to any other payments to Contractor. For Work items or components that are deleted in their entirety, Contractor will only be entitled to compensation for those direct, actual, and documented costs (including restocking fees), reasonably incurred before Contractor was notified of the City's intent to delete the Work, with no markup for overhead, profit, or other indirect costs.

(A) **Unit Pricing.** Amounts previously provided by Contractor in the form of unit prices, either in a bid schedule or in a post-award schedule of values pursuant to Section 8.1, Schedule of Values, will apply to determine the price for the affected Work, to the extent applicable unit prices have been provided for that type of Work. No additional markup for overhead, profit, or other indirect costs will be added to the calculation.

(B) **Lump Sum.** A mutually agreed upon, all-inclusive lump sum price for the affected Work with no additional markup for overhead, profit, or other indirect costs.

(C) **Time and Materials.** On a time and materials basis, if and only to the extent compensation on a time and materials basis is expressly authorized by City in advance of Contractor's performance of the Work and subject to any not-to-exceed limit. Time and materials compensation for increased costs or Extra Work (but not decreased costs or deleted Work), will include allowed markup for overhead, profit, and other indirect costs, calculated as the total of the following sums, the cumulative total of which may not exceed the maximum markup rate of 15%:

- (1) All direct labor costs provided by the Contractor, excluding superintendence, project management, or administrative costs, plus 15% markup;
- (2) All direct material costs provided by the Contractor, including sales tax, plus 15% markup;
- (3) All direct plant and equipment rental costs provided by the Contractor, plus 15% markup;
- (4) All direct additional subcontract costs plus 10% markup for Work performed by Subcontractors; and
- (5) Increased bond or insurance premium costs computed at 1.5% of total of the previous four sums.

6.4 Unilateral Change Order. If the parties dispute the terms of a proposed Change Order, including disputes over the amount of compensation or extension of time that Contractor has requested, the value of deleted or changed Work, what constitutes Extra Work, or quantities used, City may elect to issue a unilateral Change Order, directing performance of the Work, and authorizing a change in the Contract Price or Contract Time for the adjustment to compensation or time that the City believes is merited. Contractor's sole recourse to dispute the terms of a unilateral Change Order is to submit a timely Claim pursuant to Article 12, below.

6.5 Non-Compliance Deemed Waiver. Contractor waives its entitlement to any increase in the Contract Price or Contract Time if Contractor fails to fully comply with the provisions of this Article. Contractor will not be paid for unauthorized Extra Work.

Article 7 - General Construction Provisions

7.1 Permits, Fees, Business License, and Taxes.

(A) **Permits, Fees, and City Business License.** Contractor must obtain and pay for all permits, fees, or licenses required to perform the Work, including a City business license. Contractor must cooperate with and provide notifications to all government agencies with jurisdiction over the Project, as may be required. Contractor must provide City with copies of all records of permits and permit applications, payment of required fees, and any licenses required for the Work.

(B) **Taxes.** Contractor must pay for all taxes on labor, material and equipment, except Federal Excise Tax to the extent that City is exempt from Federal Excise Tax.

7.2 Temporary Facilities. Contractor must provide, at Contractor's sole expense, any and all temporary facilities for the Project, including an onsite staging area for materials and equipment, a field office, sanitary facilities, utilities, storage, scaffolds, barricades, walkways, and any other temporary structure required to safely perform the Work along with any incidental utility services. The location of all temporary facilities must be

approved by the City prior to installation. Temporary facilities must be safe and adequate for the intended use and installed and maintained in accordance with Laws and the Contract Documents. Contractor must fence and screen the Project site and, if applicable, any separate Worksites, including the staging area, and its operation must minimize inconvenience to neighboring properties. Additional provisions pertaining to temporary facilities may be included in the Specifications or Special Conditions.

(A) **Utilities.** Contractor must install and maintain the power, water, sewer and all other utilities required for the Project site, including the piping, wiring, internet and wifi connections, and any related equipment necessary to maintain the temporary facilities.

(B) **Removal and Repair.** Contractor must promptly remove all such temporary facilities when they are no longer needed or upon completion of the Work, whichever comes first. Contractor must promptly repair any damage to City's property or to other property caused by the installation, use, or removal of the temporary facilities, and must promptly restore the property to its original or intended condition.

7.3 Noninterference and Site Management. Contractor must avoid interfering with City's use of its property at or adjacent to the Project site, including use of roadways, entrances, parking areas, walkways, and structures. Contractor must also minimize disruption of access to private property in the Project vicinity. Contractor must coordinate with affected property owners, tenants, and businesses, and maintain some vehicle and pedestrian access to their residences or properties at all times. Temporary access ramps, fencing or other measures must be provided as needed. Before blocking access to a private driveway or parking lot, Contractor must provide effective notice to the affected parties at least 48 hours in advance of the pending closure and allow them to remove vehicles. Private driveways, residences and parking lots must have access to a roadway during non-Work hours.

(A) **Offsite Acquisition.** Unless otherwise provided by City, Contractor must acquire, use and dispose of, at its sole expense, any Worksites, licenses, easements, and temporary facilities necessary to access and perform the Work.

(B) **Offsite Staging Area and Field Office.** If additional space beyond the Project site is needed, such as for the staging area or the field office, Contractor may need to make arrangements with the nearby property owner(s) to secure the space. Before using or occupying any property owned by a third party, Contractor must provide City with a copy of the necessary license agreement, easement, or other written authorization from the property owner, together with a written release from the property owner holding City harmless from any related liability, in a form acceptable to the City Attorney.

(C) **Traffic Management.** Contractor must provide traffic management and traffic controls as specified in the Contract Documents, as required by Laws, and as otherwise required to ensure public and worker safety, and to avoid interference with public or private operations or the normal flow of vehicular, bicycle, or pedestrian traffic.

7.4 Signs. No signs may be displayed on or about City's property, except signage which is required by Laws or by the Contract Documents, without City's prior written approval as to size, design, and location.

7.5 Project Site and Nearby Property Protections.

(A) **General.** Contractor is responsible at all times, on a 24-hour basis and at its sole cost, for protecting the Work, the Project site, and the materials and equipment to be incorporated into the Work, until the City has accepted the Project, excluding any exceptions to acceptance, if any. Except as specifically authorized by City, Contractor

must confine its operations to the area of the Project site indicated in the Plans and Specifications. Contractor is liable for any damage caused by Contractor or its Subcontractors to the Work, City's property, the property of adjacent or nearby property owners and the work or personal property of other contractors working for City, including damage related to Contractor's failure to adequately secure the Work or any Worksite.

(1) Subject to City's approval, Contractor will provide and install safeguards to protect the Work; any Worksite, including the Project site; City's real or personal property and the real or personal property of adjacent or nearby property owners, including plant and tree protections.

(2) City wastewater systems may not be interrupted. If the Work disrupts existing sewer facilities, Contractor must immediately notify City and establish a plan, subject to City's approval, to convey the sewage in closed conduits back into the sanitary sewer system. Sewage must not be permitted to flow in trenches or be covered by backfill.

(3) Contractor must remove with due care, and store at City's request, any objects or material from the Project site that City will salvage or reuse at another location.

(4) If directed by Engineer, Contractor must promptly repair or replace any property damage, as specified by the Engineer. However, acting in its sole discretion, City may elect to have the property damage remedied otherwise, and may deduct the cost to repair or replace the damaged property from payment otherwise due to Contractor.

(5) Contractor will not permit any structure or infrastructure to be loaded in a manner that will damage or endanger the integrity of the structure or infrastructure.

(B) **Securing Project Site.** After completion of Work each day, Contractor must secure the Project site and, to the extent feasible, make the area reasonably accessible to the public unless City approves otherwise. All excess materials and equipment not protected by approved traffic control devices must be relocated to the staging area or demobilized. Trench spoils must be hauled off the Project site daily and open excavations must be protected with steel plates. Contractor and Subcontractor personnel may not occupy or use the Project site for any purpose during non-Work hours, except as may be provided in the Contract Documents or pursuant to prior written authorization from City.

(C) **Unforeseen Conditions.** If Contractor encounters facilities, utilities, or other unknown conditions not shown on or reasonably inferable from the Plans or apparent from inspection of the Project site, Contractor must immediately notify the City and promptly submit a Request for Information to obtain further directions from the Engineer. Contractor must avoid taking any action which could cause damage to the facilities or utilities pending further direction from the Engineer. The Engineer's written response will be final and binding on Contractor. If the Engineer's subsequent direction to Contractor affects Contractor's cost or time to perform the Work, Contractor may submit a Change Order request as set forth in Article 6 above.

(D) **Support; Adjacent Properties.** Contractor must provide, install, and maintain all shoring, bracing, and underpinning necessary to provide support to City's property and adjacent properties and improvements thereon. Contractor must provide notifications to adjacent property owners as may be required by Laws. See also, Section 7.15, Trenching of Five Feet or More.

(E) **Notification of Property Damage.** Contractor must immediately notify the City of damage to any real or personal property resulting from Work on the Project. Contractor must immediately provide a written report to City of any such property damage in excess of \$500 (based on estimated cost to repair or replace) within 24 hours of the occurrence. The written report must include: (1) the location and nature of the damage, and the owner of the property, if known; (2) the name and address of each employee of Contractor or any Subcontractor involved in the damage; (3) a detailed description of the incident, including precise location, time, and names and contact information for known witnesses; and (4) a police or first responder report, if applicable. If Contractor is required to file an accident report with another government agency, Contractor will provide a copy of the report to City.

7.6 Materials and Equipment.

(A) **General.** Unless otherwise specified, all materials and equipment required for the Work must be new, free from defects, and of the best grade for the intended purpose, and furnished in sufficient quantities to ensure the proper and expeditious performance of the Work. Contractor must employ measures to preserve the specified quality and fitness of the materials and equipment. Unless otherwise specified, all materials and equipment required for the Work are deemed to include all components required for complete installation and intended operation and must be installed in accordance with the manufacturer's recommendations or instructions. Contractor is responsible for all shipping, handling, and storage costs associated with the materials and equipment required for the Work. Contractor is responsible for providing security and protecting the Work and all of the required materials, supplies, tools and equipment at Contractor's sole cost until City has formally accepted the Project as set forth in Section 11.1, Final Completion. Contractor will not assign, sell, mortgage, or hypothecate any materials or equipment for the Project, or remove any materials or equipment that have been installed or delivered.

(B) **City-Provided.** If the Work includes installation of materials or equipment to be provided by City, Contractor is solely responsible for the proper examination, handling, storage, and installation in accordance with the Contract Documents. Contractor must notify City of any defects discovered in City-provided materials or equipment, sufficiently in advance of scheduled use or installation to afford adequate time to procure replacement materials or equipment as needed. Contractor is solely responsible for any loss of or damage to such items which occurs while the items are in Contractor's custody and control, the cost of which may be offset from the Contract Price and deducted from any payment(s) due to Contractor.

(C) **Intellectual Property Rights.** Contractor must, at its sole expense, obtain any authorization or license required for use of patented or copyright-protected materials, equipment, devices or processes that are incorporated into the Work. Contractor's indemnity obligations in Article 4 apply to any claimed violation of intellectual property rights in violation of this provision.

7.7 Substitutions.

(A) **"Or Equal."** Any Specification designating a material, product, or thing (collectively, "item") or service by specific brand or trade name, followed by the words "or equal," is intended only to indicate the quality and type of item or service desired, and Contractor may request use of any equal item or service. Unless otherwise stated in the Specifications, any reference to a specific brand or trade name for an item or service that is used solely for the purpose of describing the type of item or service desired, will be deemed to be followed by the words "or equal." A substitution will only be approved if it is a true "equal" item or service in every aspect of design, function, and quality, as

determined by City, including dimensions, weight, maintenance requirements, durability, fit with other elements, and schedule impacts.

(B) **Request for Substitution.** A post-award request for substitution of an item or service must be submitted in writing to the Engineer for approval in advance, within the applicable time period provided in the Contract Documents. If no time period is specified, the substitution request may be submitted any time within 35 days after the date of award of the Contract, or sufficiently in advance of the time needed to avoid delay of the Work, whichever is earlier.

(C) **Substantiation.** Any available data substantiating the proposed substitute as an equal item or service must be submitted with the written request for substitution. Contractor's failure to timely provide all necessary substantiation, including any required test results as soon as they are available, is grounds for rejection of the proposed substitution, without further review.

(D) **Burden of Proving Equality.** Contractor has the burden of proving the equality of the proposed substitution at Contractor's sole cost. City has sole discretion to determine whether a proposed substitution is equal, and City's determination is final.

(E) **Approval or Rejection.** If the proposed substitution is approved, Contractor is solely responsible for any additional costs or time associated with the substituted item or service. If the proposed substitution is rejected, Contractor must, without delay, install the item or use the service as specified by City.

(F) **Contractor's Obligations.** City's approval of a proposed substitution will not relieve Contractor from any of its obligations under the Contract Documents. In the event Contractor makes an unauthorized substitution, Contractor will be solely responsible for all resulting cost impacts, including the cost of removal and replacement and the impact to other design elements.

7.8 Testing and Inspection.

(A) **General.** All materials, equipment, and workmanship used in the Work are subject to inspection and testing by City at all times and locations during construction and/or fabrication and at any Worksite, including at shops and yards as well as at the Project site. All manufacturers' application or installation instructions must be provided to the Inspector at least ten days prior to the first such application or installation. Contractor must, at all times, make the Work available for testing or inspection. Neither City's inspection or testing of Work, nor its failure to do so, operate to waive or limit Contractor's duty to complete the Work in accordance with the Contract Documents.

(B) **Scheduling and Notification.** Contractor must cooperate with City in coordinating the inspections and testing. Contractor must submit samples of materials, at Contractor's expense, and schedule all tests required by the Contract Documents in time to avoid any delay to the progress of the Work. Contractor must notify the Engineer no later than noon of the Working Day before any inspection or testing and must provide timely notice to the other necessary parties as specified in the Contract Documents. If Contractor schedules an inspection or test beyond regular Work hours, or on a Saturday, Sunday, or recognized City holiday, Contractor must notify the Engineer at least two Working Days in advance for approval. If approved, Contractor must reimburse City for the cost of the overtime inspection or testing. Such costs, including the City's hourly costs for required personnel, may be deducted from payments otherwise due to Contractor.

(C) **Responsibility for Costs.** City will bear the initial cost of inspection and testing to be performed by independent testing consultants retained by City, subject to the following exceptions:

(1) Contractor will be responsible for the costs of any subsequent tests which are required to substantiate compliance with the Contract Documents, and any associated remediation costs.

(2) Contractor will be responsible for inspection costs, at City's hourly rates, for inspection time lost because the Work is not ready or Contractor fails to appear for a scheduled inspection.

(3) If any portion of the Work that is subject to inspection or testing is covered or concealed by Contractor prior to the inspection or testing, Contractor will bear the cost of making that portion of the Work available for the inspection or testing required by the Contract Documents, and any associated repair or remediation costs.

(4) Contractor is responsible for properly shoring all compaction test sites deeper than five feet below grade, as required under Section 7.15 below.

(5) Any Work or material that is defective or fails to comply with the requirements of the Contract Documents must be promptly repaired, removed, replaced, or corrected by Contractor, at Contractor's sole expense, even if that Work or material was previously inspected or included in a progress payment.

(D) **Contractor's Obligations.** Contractor is solely responsible for any delay occasioned by remediation of defective or noncompliant Work or material. Inspection of the Work does not in any way relieve Contractor of its obligations to perform the Work as specified. Any Work done without the required inspection(s) will also be subject to rejection by City.

(E) **Distant Locations.** If required off-site testing or inspection must be conducted at a location more than 100 miles from the Project site, Contractor is solely responsible for the additional travel costs required for testing and/or inspection at such locations.

(F) **Final Inspection.** The provisions of this Section 7.8 also apply to final inspection under Article 11, Completion and Warranty Provisions.

7.9 Project Site Conditions and Maintenance. Contractor must at all times, on a 24-hour basis and at its sole cost, maintain the Project site and staging and storage areas in clean, neat, and sanitary condition and in compliance with all Laws pertaining to safety, air quality, and dust control. Adequate toilets must be provided, and properly maintained and serviced for all workers on the Project site, located in a suitably secluded area, subject to City's prior approval. Contractor must also, on a daily basis and at its sole cost, remove and properly dispose of the debris and waste materials from the Project site.

(A) **Air Emissions Control.** Contractor must not discharge smoke or other air contaminants into the atmosphere in violation of any Laws.

(B) **Dust and Debris.** Contractor must minimize and confine dust and debris resulting from the Work. Contractor must abate dust nuisance by cleaning, sweeping, and immediately sprinkling with water excavated areas of dirt or other materials prone to cause dust, and within one hour after the Engineer notifies Contractor that an airborne nuisance exists. The Engineer may direct that Contractor provide an approved water-spraying truck for this purpose. If water is used for dust control, Contractor will only use

the minimum necessary. Contractor must take all necessary steps to keep waste water out of streets, gutters, or storm drains. See Section 7.19, Environmental Control. If City determines that the dust control is not adequate, City may have the work done by others and deduct the cost from the Contract Price. Contractor will immediately remove any excess excavated material from the Project site and any dirt deposited on public streets.

(C) **Clean up.** Before discontinuing Work in an area, Contractor must clean the area and remove all debris and waste along with the construction equipment, tools, machinery, and surplus materials.

(1) Except as otherwise specified, all excess Project materials, and the materials removed from existing improvements on the Project site with no salvage value or intended reuse by City, will be Contractor's property.

(2) Hauling trucks and other vehicles leaving the Project site must be cleaned of exterior mud or dirt before traveling on City streets. Materials and loose debris must be delivered and loaded to prevent dropping materials or debris. Contractor must immediately remove spillage from hauling on any publicly traveled way. Streets affected by Work on the Project must be kept clean by street sweeping.

(D) **Disposal.** Contractor must dispose of all Project debris and waste materials in a safe and legal manner. Contractor may not burn or bury waste materials on the Project site. Contractor will not allow any dirt, refuse, excavated material, surplus concrete or mortar, or any associated washings, to be disposed of onto streets, into manholes or into the storm drain system.

(E) **Completion.** At the completion of the Work, Contractor must remove from the Project site all of its equipment, tools, surplus materials, waste materials and debris, presenting a clean and neat appearance. Before demobilizing from the Project site, Contractor must ensure that all surfaces are cleaned, sealed, waxed, or finished as applicable, and that all marks, stains, paint splatters, and the like have been properly removed from the completed Work and the surrounding areas. Contractor must ensure that all parts of the construction are properly joined with the previously existing and adjacent improvements and conditions. Contractor must provide all cutting, fitting and patching needed to accomplish that requirement. Contractor must also repair or replace all existing improvements that are damaged or removed during the Work, both on and off the Project site, including curbs, sidewalks, driveways, fences, signs, utilities, street surfaces and structures. Repairs and replacements must be at least equal to the previously existing improvements, and the condition, finish and dimensions must match the previously existing improvements. Contractor must restore to original condition all property or items that are not designated for alteration under the Contract Documents and leave each Worksite clean and ready for occupancy or use by City.

(F) **Non-Compliance.** If Contractor fails to comply with its maintenance and cleanup obligations or any City clean up order, City may, acting in its sole discretion, elect to suspend the Work until the condition(s) is corrected with no increase in the Contract Time or Contract Price, or undertake appropriate cleanup measures without further notice and deduct the cost from any amounts due or to become due to Contractor.

7.10 Instructions and Manuals. Contractor must provide to City three copies each of all instructions and manuals required by the Contract Documents, unless otherwise specified. These must be complete as to drawings, details, parts lists, performance data, and other information that may be required for City to easily maintain and service the materials and equipment installed for this Project.

(A) **Submittal Requirements.** All manufacturers' application or installation instructions must be provided to City at least ten days prior to the first such application. The instructions and manuals, along with any required guarantees, must be delivered to City for review.

(B) **Training.** Contractor or its Subcontractors must train City's personnel in the operation and maintenance of any complex equipment or systems as a condition precedent to Final Completion, if required in the Contract Documents.

7.11 As-built Drawings. Contractor and its Subcontractors must prepare and maintain at the Project site a detailed, complete and accurate as-built set of the Plans which will be used solely for the purpose of recording changes made in any portion of the original Plans in order to create accurate record drawings at the end of the Project.

(A) **Duty to Update.** The as-built drawings must be updated as changes occur, on a daily basis if necessary. City may withhold the estimated cost for City to have the as-built drawings prepared from payments otherwise due to Contractor, until the as-built drawings are brought up to date to the satisfaction of City. Actual locations to scale must be identified on the as-built drawings for all runs of mechanical and electrical work, including all site utilities installed underground, in walls, floors, or otherwise concealed. Deviations from the original Plans must be shown in detail. The exact location of all main runs, whether piping, conduit, ductwork or drain lines, must be shown by dimension and elevation. The location of all buried pipelines, appurtenances, or other improvements must be represented by coordinates and by the horizontal distance from visible above-ground improvements.

(B) **Final Completion.** Contractor must verify that all changes in the Work are depicted in the as-built drawings and must deliver the complete set of as-built drawings to the Engineer for review and acceptance as a condition precedent to Final Completion and Final Payment.

7.12 Existing Utilities.

(A) **General.** The Work may be performed in developed, urban areas with existing utilities, both above and below ground, including utilities identified in the Contract Documents or in other informational documents or records. Contractor must take due care to locate identified or reasonably identifiable utilities before proceeding with trenching, excavation, or any other activity that could damage or disrupt existing utilities. This may include excavation with small equipment, potholing, or hand excavation, and, if practical, using white paint or other suitable markings to delineate the area to be excavated. Except as otherwise provided herein, Contractor will be responsible for costs resulting from damage to identified or reasonably identifiable utilities due to Contractor's negligence or failure to comply with the Contract Documents, including the requirements in this Article 7.

(B) **Unidentified Utilities.** Pursuant to Government Code § 4215, if, during the performance of the Work, Contractor discovers utility facilities not identified by City in the Contract Documents, Contractor must immediately provide written notice to City and the utility. City assumes responsibility for the timely removal, relocation, or protection of existing main or trunkline utility facilities located on the Project site if those utilities are not identified in the Contract Documents. Contractor will be compensated in accordance with the provisions of the Contract Documents for the costs of locating, repairing damage not due to Contractor's failure to exercise reasonable care, and removing or relocating utility facilities not indicated in the Plans or Specifications with reasonable accuracy, and for equipment on the Project necessarily idled during such work. Contractor will not be

assessed liquidated damages for delay in completion of the Work, to the extent the delay was caused by City's failure to provide for removal or relocation of the utility facilities.

7.13 Notice of Excavation. Contractor must comply with all applicable requirements in Government Code §§ 4216 through 4216.5, which are incorporated by reference herein. Government Code § 4216.2 requires that, except in an emergency, Contractor must contact the appropriate regional notification center, or Underground Services Alert, at least two working days, but not more than 14 calendar days, before starting any excavation if the excavation will be conducted in an area that is known, or reasonably should be known, to contain subsurface installations. Contractor may not begin excavation until it has obtained and submitted to Engineer an inquiry identification number from Underground Services Alert.

7.14 Trenching and Excavations of Four Feet or More. As required by Public Contract Code § 7104, if the Work includes digging trenches or other excavations that extend deeper than four feet below the surface, the provisions in this Section apply to the Work and the Project.

(A) **Duty to Notify.** Contractor must promptly, and before the following conditions are disturbed, provide written notice to City if Contractor finds any of the following conditions:

(1) Material that Contractor believes may be a hazardous waste, as defined in § 25117 of the Health and Safety Code, that is required to be removed to a Class I, Class II, or Class III disposal site in accordance with the provisions of existing Laws;

(2) Subsurface or latent physical conditions at the Project site differing from those indicated by information about the Project site made available to bidders prior to the deadline for submitting bids; or

(3) Unknown physical conditions at the Project site of any unusual nature, materially different from those ordinarily encountered and generally recognized as inherent in work of the character required by the Contract Documents.

(B) **City Investigation.** City will promptly investigate the conditions and if City finds that the conditions materially differ from those indicated, apparent, or reasonably inferred from information about the Project site made available to bidders, or involve hazardous waste, and cause a decrease or increase in Contractor's cost of, or the time required for, performance of any part of the Work, City will issue a Change Order.

(C) **Disputes.** In the event that a dispute arises between City and Contractor regarding any of the conditions specified in subsection (B) above, or the terms of a Change Order issued by City, Contractor will not be excused from completing the Work within the Contract Time, but must proceed with all Work to be performed under the Contract. Contractor will retain any and all rights provided either by the Contract or by Laws which pertain to the resolution of disputes between Contractor and City.

7.15 Trenching of Five Feet or More. As required by Labor Code § 6705, if the Contract Price exceeds \$25,000 and the Work includes the excavation of any trench or trenches of five feet or more in depth, a detailed plan must be submitted to City for acceptance in advance of the excavation. The detailed plan must show the design of shoring, bracing, sloping, or other provisions to be made for worker protection from the hazard of caving ground during the excavation. If the plan varies from the shoring system standards, it must be prepared by a California registered civil or structural engineer. Use of a shoring,

sloping, or protective system less effective than that required by the Construction Safety Orders is prohibited.

7.16 New Utility Connections. Except as otherwise specified, City will pay connection charges and meter costs for new permanent utilities required by the Contract Documents, if any. Contractor must notify City sufficiently in advance of the time needed to request service from each utility provider so that connections and services are initiated in accordance with the Project schedule.

7.17 Lines and Grades. Contractor is required to use any benchmark provided by the Engineer. Unless otherwise specified in the Contract Documents, Contractor must provide all lines and grades required to execute the Work. Contractor must also provide, preserve, and replace if necessary, all construction stakes required for the Project. All stakes or marks must be set by a California licensed surveyor or a California registered civil engineer. Contractor must notify the Engineer of any discrepancies found between Contractor's staking and grading and information provided by the Contract Documents. Upon completion, all Work must conform to the lines, elevations, and grades shown in the Plans, including any changes directed by a Change Order.

7.18 Historic or Archeological Items.

(A) **Contractor's Obligations.** Contractor must ensure that all persons performing Work at the Project site are required to immediately notify the Project Manager, upon discovery of any potential historic or archeological items, including historic or prehistoric ruins, a burial ground, archaeological or vertebrate paleontological site, including fossilized footprints or other archeological, paleontological or historical feature on the Project site (collectively, "Historic or Archeological Items").

(B) **Discovery; Cessation of Work.** Upon discovery of any potential Historic or Archeological Items, Work must be stopped within an 85-foot radius of the find and may not resume until authorized in writing by City. If required by City, Contractor must assist in protecting or recovering the Historic or Archeological Items, with any such assistance to be compensated as Extra Work on a time and materials basis under Article 6, Contract Modification. At City's discretion, a suspension of Work required due to discovery of Historic or Archeological Items may be treated as Excusable Delay pursuant to Article 5, or as a suspension for convenience under Article 13.

7.19 Environmental Control. Contractor must not pollute any drainage course or its tributary inlets with fuels, oils, bitumens, acids, insecticides, herbicides or other harmful materials. Contractor must prevent the release of any hazardous material or hazardous waste into the soil or groundwater, and prevent the unlawful discharge of pollutants into City's storm drain system and watercourses as required below. Contractor and its Subcontractors must at all times in the performance of the Work comply with all Laws concerning pollution of waterways.

(A) **Stormwater Permit.** Contractor must comply with all applicable conditions of the State Water Resources Control Board National Pollutant Discharge Elimination System General Permit for Waste Discharge Requirements for Discharges of Stormwater Runoff Associated with Construction Activity ("Stormwater Permit").

(B) **Contractor's Obligations.** If required for the Work, a copy of the Stormwater Permit is on file in City's principal administrative offices, and Contractor must comply with it without adjustment of the Contract Price or the Contract Time. Contractor must timely and completely submit required reports and monitoring information required by the conditions of the Stormwater Permit. Contractor also must comply with all other Laws

governing discharge of stormwater, including applicable municipal stormwater management programs.

- 7.20 Noise Control.** Contractor must comply with all applicable noise control Laws. Noise control requirements apply to all equipment used for the Work or related to the Work, including trucks, transit mixers or transient equipment that may or may not be owned by Contractor.
- 7.21 Mined Materials.** Pursuant to the Surface Mining and Reclamation Act of 1975, Public Resources Code § 2710 et seq., any purchase of mined materials, such as construction aggregate, sand, gravel, crushed stone, road base, fill materials, and any other mineral materials must originate from a surface mining operation included on the AB 3098 List, which is available online at:
<ftp://ftp.consrv.ca.gov/pub/omr/AB3098%20List/AB3908List.pdf>.

Article 8 - Payment

- 8.1 Schedule of Values.** Prior to submitting its first application for payment, Contractor must prepare and submit to the Project Manager a schedule of values apportioned to the various divisions and phases of the Work, including mobilization and demobilization. If a Bid Schedule was submitted with Contractor's bid, the amounts in the schedule of values must be consistent with the Bid Schedule. Each line item contained in the schedule of values must be assigned a value such that the total of all items equals the Contract Price. The items must be sufficiently detailed to enable accurate evaluation of the percentage of completion claimed in each application for payment, and the assigned value consistent with any itemized or unit pricing submitted with Contractor's bid.
- (A) **Measurements for Unit Price Work.** Materials and items of Work to be paid for on the basis of unit pricing will be measured according to the methods specified in the Contract Documents.
- (B) **Deleted or Reduced Work.** Contractor will not be compensated for Work that City has deleted or reduced in scope, except for any labor, material or equipment costs for such Work that Contractor reasonably incurred before Contractor learned that the Work could be deleted or reduced. Contractor will only be compensated for those actual, direct and documented costs incurred, and will not be entitled to any mark up for overhead or lost profits.
- 8.2 Progress Payments.** Following the last day of each month, or as otherwise required by the Special Conditions or Specifications, Contractor will submit to the Project Manager a monthly application for payment for Work performed during the preceding month based on the estimated value of the Work performed during that preceding month.
- (A) **Application for Payment.** Each application for payment must be itemized to include labor, materials, and equipment incorporated into the Work, and materials and equipment delivered to the Project site, as well as authorized and approved Change Orders. Each payment application must be supported by the unit prices submitted with Contractor's Bid Schedule and/or schedule of values and any other substantiating data required by the Contract Documents.
- (B) **Payment of Undisputed Amounts.** City will pay the undisputed amount due within 30 days after Contractor has submitted a complete and accurate payment application, subject to Public Contract Code § 20104.50. City will deduct a percentage from each progress payment as retention, as set forth in Section 8.5, below, and may withhold additional amounts as set forth in Section 8.3, below.

8.3 Adjustment of Payment Application. City may adjust or reject the amount requested in a payment application, including application for Final Payment, in whole or in part, if the amount requested is disputed or unsubstantiated. Contractor will be notified in writing of the basis for the modification to the amount requested. City may also deduct or withhold from payment otherwise due based upon any of the circumstances and amounts listed below. Sums withheld from payment otherwise due will be released when the basis for that withholding has been remedied and no longer exists.

(A) For Contractor's unexcused failure to perform the Work as required by the Contract Documents, including correction or completion of punch list items, City may withhold or deduct an amount based on the City's estimated cost to correct or complete the Work.

(B) For loss or damage caused by Contractor or its Subcontractors arising out of or relating to performance of the Work or any failure to protect the Project site, City may deduct an amount based on the estimated cost to repair or replace.

(C) For Contractor's failure to pay its Subcontractors and suppliers when payment is due, City may withhold an amount equal to the total of past due payments and may opt to pay that amount separately via joint check pursuant to Section 8.6(B), Joint Checks.

(D) For Contractor's failure to timely correct rejected, nonconforming, or defective Work, City may withhold or deduct an amount based on the City's estimated cost to correct or complete the Work.

(E) For any unreleased stop notice, City may withhold 125% of the amount claimed.

(F) For Contractor's failure to submit any required schedule or schedule update in the manner and within the time specified in the Contract Documents, City may withhold an amount equal to five percent of the total amount requested until Contractor complies with its schedule submittal obligations.

(G) For Contractor's failure to maintain or submit as-built documents in the manner and within the time specified in the Contract Documents, City may withhold or deduct an amount based on the City's cost to prepare the as-builts.

(H) For Work performed without Shop Drawings that have been accepted by City, when accepted Shop Drawings are required before proceeding with the Work, City may deduct an amount based on the estimated cost to correct unsatisfactory Work or diminution in value.

(I) For fines, payments, or penalties assessed under the Labor Code, City may deduct from payments due to Contractor as required by Laws and as directed by the Division of Labor Standards Enforcement.

(J) For any other costs or charges that may be withheld or deducted from payments to Contractor, as provided in the Contract Documents, including liquidated damages, City may withhold or deduct such amounts from payment otherwise due to Contractor.

8.4 Early Occupancy. Neither City's payment of progress payments nor its partial or full use or occupancy of the Project constitutes acceptance of any part of the Work.

8.5 Retention. City will retain five percent of the full amount due on each progress payment (i.e., the amount due before any withholding or deductions pursuant to Section 8.3, Adjustment of Payment Application), or the percentage stated in the Notice Inviting Bids, whichever is greater, as retention to ensure full and satisfactory performance of the Work.

Contractor is not entitled to any reduction in the rate of withholding at any time, nor to release of any retention before 35 days following City's acceptance of the Project.

(A) **Substitution of Securities.** As provided by Public Contract Code § 22300, Contractor may request in writing that it be allowed, at its sole expense, to substitute securities for the retention withheld by City. Any escrow agreement entered into pursuant to this provision must fully comply with Public Contract Code § 22300 and will be subject to approval as to form by City's legal counsel. If City exercises its right to draw upon such securities in the event of default pursuant to section (7) of the statutory Escrow Agreement for Security Deposits in Lieu of Retention, pursuant to subdivision (f) of Public Contract Code § 22300 ("Escrow Agreement"), and if Contractor disputes that it is in default, its sole remedy is to comply with the dispute resolution procedures in Article 12 and the provisions therein. It is agreed that for purposes of this paragraph, an event of default includes City's rights pursuant to these Contract Documents to withhold or deduct sums from retention, including withholding or deduction for liquidated damages, incomplete or defective Work, stop payment notices, or backcharges. It is further agreed that if any individual authorized to give or receive written notice on behalf of a party pursuant to section (10) of the Escrow Agreement are unavailable to give or receive notice on behalf of that party due to separation from employment, retirement, death, or other circumstances, the successor or delegee of the named individual is deemed to be the individual authorized to give or receive notice pursuant to section (10) of the Escrow Agreement.

(B) **Release of Undisputed Retention.** All undisputed retention, less any amounts that may be assessed as liquidated damages, retained for stop notices, or otherwise withheld pursuant to Section 8.3, Adjustment of Payment Application, will be released as Final Payment to Contractor no sooner than 35 days following recordation of the notice of completion, and no later than 60 days following acceptance of the Project by City's governing body or authorized designee pursuant to Section 11.1(C), Acceptance, or, if the Project has not been accepted, no later than 60 days after the Project is otherwise considered complete pursuant to Public Contract Code § 7107(c).

8.6 Payment to Subcontractors and Suppliers. Each month, Contractor must promptly pay each Subcontractor and supplier the value of the portion of labor, materials, and equipment incorporated into the Work or delivered to the Project site by the Subcontractor or supplier during the preceding month. Such payments must be made in accordance with the requirements of Laws pertaining to such payments, and those of the Contract Documents and applicable subcontract or supplier contract.

(A) **Withholding for Stop Notice.** Pursuant to Civil Code § 9358, City will withhold 125% of the amount claimed by an unreleased stop notice, a portion of which may be retained by City for the costs incurred in handling the stop notice claim, including attorneys' fees and costs, as authorized by law.

(B) **Joint Checks.** City reserves the right, acting in its sole discretion, to issue joint checks made payable to Contractor and a Subcontractor or supplier, if City determines this is necessary to ensure fair and timely payment for a Subcontractor or supplier who has provided services or goods for the Project. As a condition to release of payment by a joint check, the joint check payees may be required to execute a joint check agreement in a form provided or approved by the City Attorney's Office. The joint check payees will be jointly and severally responsible for the allocation and disbursement of funds paid by joint check. Payment by joint check will not be construed to create a contractual relationship between City and a Subcontractor or supplier of any tier beyond the scope of the joint check agreement.

- 8.7 Final Payment.** Contractor's application for Final Payment must comply with the requirements for submitting an application for a progress payment as stated in Section 8.2, above. Corrections to previous progress payments, including adjustments to estimated quantities for unit priced items, may be included in the Final Payment. If Contractor fails to submit a timely application for Final Payment, City reserves the right to unilaterally process and issue Final Payment without an application from Contractor in order to close out the Project. For the purposes of determining the deadline for Claim submission pursuant to Article 12, the date of Final Payment is deemed to be the date that City acts to release undisputed retention as final payment to Contractor, or otherwise provides written notice to Contractor of Final Payment or that no undisputed funds remain available for Final Payment due to offsetting withholdings or deductions pursuant to Section 8.3, Adjustment of Payment Application. If the amount due from Contractor to City exceeds the amount of Final Payment, City retains the right to recover the balance from Contractor or its sureties.
- 8.8 Release of Claims.** City may, at any time, require that payment of the undisputed portion of any progress payment or Final Payment be contingent upon Contractor furnishing City with a written waiver and release of all claims against City arising from or related to the portion of Work covered by those undisputed amounts subject to the limitations of Public Contract Code § 7100. Any disputed amounts may be specifically excluded from the release.
- 8.9 Warranty of Title.** Contractor warrants that title to all work, materials, or equipment incorporated into the Work and included in a request for payment will pass over to City free of any claims, liens, or encumbrances upon payment to Contractor.

Article 9 - Labor Provisions

- 9.1 Discrimination Prohibited.** Discrimination against any prospective or present employee engaged in the Work on grounds of race, color, ancestry, national origin, ethnicity, religion, sex, sexual orientation, age, disability, or marital status is strictly prohibited. Contractor and its Subcontractors are required to comply with all applicable Laws prohibiting discrimination, including the California Fair Employment and Housing Act (Govt. Code § 12900 et seq.), Government Code § 11135, and Labor Code §§ 1735, 1777.5, 1777.6, and 3077.5.
- 9.2 Labor Code Requirements.**
- (A) **Eight Hour Day.** Pursuant to Labor Code § 1810, eight hours of labor constitute a legal day's work under this Contract.
- (B) **Penalty.** Pursuant to Labor Code § 1813, Contractor will forfeit to City as a penalty, the sum of \$25.00 for each day during which a worker employed by Contractor or any Subcontractor is required or permitted to work more than eight hours in any one calendar day or more than 40 hours per calendar week, except if such workers are paid overtime under Labor Code § 1815.
- (C) **Apprentices.** Contractor is responsible for compliance with the requirements governing employment and payment of apprentices, as set forth in Labor Code § 1777.5, which is fully incorporated by reference.
- (D) **Notices.** Pursuant to Labor Code § 1771.4, Contractor is required to post all job site notices prescribed by Laws.

9.3 Prevailing Wages. Each worker performing Work under this Contract that is covered under Labor Code §§ 1720 or 1720.9, including cleanup at the Project site, must be paid at a rate not less than the prevailing wage as defined in §§ 1771 and 1774 of the Labor Code. The prevailing wage rates are on file with the City and available online at <http://www.dir.ca.gov/dlsr>. Contractor must post a copy of the applicable prevailing rates at the Project site.

(A) **Penalties.** Pursuant to Labor Code § 1775, Contractor and any Subcontractor will forfeit to City as a penalty up to \$200.00 for each calendar day, or portion thereof, for each worker paid less than the applicable prevailing wage rate. Contractor must also pay each worker the difference between the applicable prevailing wage rate and the amount actually paid to that worker.

(B) **Federal Requirements.** If this Project is subject to federal prevailing wage requirements in addition to California prevailing wage requirements, Contractor and its Subcontractors are required to pay the higher of the currently applicable state or federal prevailing wage rates.

9.4 Payroll Records. Contractor must comply with the provisions of Labor Code §§ 1771.4, 1776, and 1812 and all implementing regulations, which are fully incorporated by this reference, including requirements for monthly electronic submission of payroll records to the DIR.

(A) **Contractor and Subcontractor Obligations.** Contractor and each Subcontractor must keep accurate payroll records, showing the name, address, social security number, work classification, straight time and overtime hours worked each day and week, and the actual per diem wages paid to each journeyman, apprentice, worker, or other employee employed in connection with the Work. Each payroll record must contain or be verified by a written declaration that it is made under penalty of perjury, stating both of the following:

(1) The information contained in the payroll record is true and correct; and

(2) Contractor or the Subcontractor has complied with the requirements of Labor Code §§ 1771, 1811, and 1815 for any Work performed by its employees on the Project.

(B) **Certified Record.** A certified copy of an employee's payroll record must be made available for inspection or furnished to the employee or his or her authorized representative on request, to City, to the Division of Labor Standards Enforcement, to the Division of Apprenticeship Standards of the DIR, and as further required by the Labor Code.

(C) **Enforcement.** Upon notice of noncompliance with Labor Code § 1776, Contractor or Subcontractor has ten days in which to comply with the requirements of this section. If Contractor or Subcontractor fails to do so within the ten-day period, Contractor or Subcontractor will forfeit a penalty of \$100.00 per day, or portion thereof, for each worker for whom compliance is required, until strict compliance is achieved. Upon request by the Division of Apprenticeship Standards, or the Division of Labor Standards Enforcement, these penalties will be withheld from payments then due to Contractor.

9.5 Labor Compliance. Pursuant to Labor Code § 1771.4, the Contract for this Project is subject to compliance monitoring and enforcement by the DIR.

Article 10 - Safety Provisions

10.1 Safety Precautions and Programs. Contractor and its Subcontractors are fully responsible for safety precautions and programs, and for the safety of persons and property in the performance of the Work. Contractor and its Subcontractors must at all times comply with all applicable health and safety Laws and seek to avoid injury, loss, or damage to persons or property by taking reasonable steps to protect its employees and other persons at any Worksite, materials and equipment stored on or off site, and property at or adjacent to any Worksite.

(A) **Reporting Requirements.** Contractor must immediately notify the City of any death, serious injury or illness resulting from Work on the Project. Contractor must immediately provide a written report to City of each recordable accident or injury occurring at any Worksite within 24 hours of the occurrence. The written report must include: (1) the name and address of the injured or deceased person; (2) the name and address of each employee of Contractor or of any Subcontractor involved in the incident; (3) a detailed description of the incident, including precise location, time, and names and contact information for known witnesses; and (4) a police or first responder report, if applicable. If Contractor is required to file an accident report with a government agency, Contractor will provide a copy of the report to City.

(B) **Legal Compliance.** Contractor's safety program must comply with the applicable legal and regulatory requirements. Contractor must provide City with copies of all notices required by Laws.

(C) **Contractor's Obligations.** Any damage or loss caused by Contractor arising from the Work which is not insured under property insurance must be promptly remedied by Contractor.

(D) **Remedies.** If City determines, in its sole discretion, that any part of the Work or Project site is unsafe, City may, without assuming responsibility for Contractor's safety program, require Contractor or its Subcontractor to cease performance of the Work or to take corrective measures to City's satisfaction. If Contractor fails to promptly take the required corrective measures, City may perform them and deduct the cost from the Contract Price. Contractor agrees it is not entitled to submit a Claim for damages, for an increase in Contract Price, or for a change in Contract Time based on Contractor's compliance with City's request for corrective measures pursuant to this provision.

10.2 Hazardous Materials. Unless otherwise specified in the Contract Documents, this Contract does not include the removal, handling, or disturbance of any asbestos or other Hazardous Materials. If Contractor encounters materials on the Project site that Contractor reasonably believes to be asbestos or other Hazardous Materials, and the asbestos or other Hazardous Materials have not been rendered harmless, Contractor may continue Work in unaffected areas reasonably believed to be safe, but must immediately cease work on the area affected and report the condition to City. No asbestos, asbestos-containing products or other Hazardous Materials may be used in performance of the Work.

10.3 Material Safety. Contractor is solely responsible for complying with § 5194 of Title 8 of the California Code of Regulations, including by providing information to Contractor's employees about any hazardous chemicals to which they may be exposed in the course of the Work. A hazard communication program and other forms of warning and training about such exposure must be used. Contractor must also maintain Safety Data Sheets ("SDS") at the Project site, as required by Laws, for materials or substances used or consumed in the performance of the Work. The SDS will be accessible and available to Contractor's employees, Subcontractors, and City.

(A) **Contractor Obligations.** Contractor is solely responsible for the proper delivery, handling, use, storage, removal, and disposal of all materials brought to the Project site and/or used in the performance of the Work. Contractor must notify the Engineer if a specified product or material cannot be used safely.

(B) **Labeling.** Contractor must ensure proper labeling on any material brought onto the Project site so that any persons working with or in the vicinity of the material may be informed as to the identity of the material, any potential hazards, and requirements for proper handling, protections, and disposal.

10.4 Hazardous Condition. Contractor is solely responsible for determining whether a hazardous condition exists or is created during the course of the Work, involving a risk of bodily harm to any person or risk of damage to any property. If a hazardous condition exists or is created, Contractor must take all precautions necessary to address the condition and ensure that the Work progresses safely under the circumstances. Hazardous conditions may result from, but are not limited to, use of specified materials or equipment, the Work location, the Project site condition, the method of construction, or the way any Work must be performed.

10.5 Emergencies. In an emergency affecting the safety or protection of persons, Work, or property at or adjacent to any Worksite, Contractor must take reasonable and prompt actions to prevent damage, injury, or loss, without prior authorization from the City if, under the circumstances, there is inadequate time to seek prior authorization from the City.

Article 11 - Completion and Warranty Provisions

11.1 Final Completion.

(A) **Final Inspection and Punch List.** When the Work required by this Contract is fully performed, Contractor must provide written notification to City requesting final inspection. The Engineer will schedule the date and time for final inspection, which must include Contractor's primary representative for this Project and its superintendent. Based on that inspection, City will prepare a punch list of any items that are incomplete, missing, defective, incorrectly installed, or otherwise not compliant with the Contract Documents. The punch list to Contractor will specify the time by which all of the punch list items must be completed or corrected. The punch list may include City's estimated cost to complete each punch list item if Contractor fails to do so within the specified time. The omission of any non-compliant item from a punch list will not relieve Contractor from fulfilling all requirements of the Contract Documents. Contractor's failure to complete any punch list item within the time specified in the punch list will not waive or abridge its warranty obligations for any such items that must be completed by the City or by a third party retained by the City due to Contractor's failure to timely complete any such outstanding item.

(B) **Requirements for Final Completion.** Final Completion will be achieved upon completion or correction of all punch list items, as verified by City's further inspection, and upon satisfaction of all other Contract requirements, including any commissioning required under the Contract Documents and submission of all final submittals, including instructions and manuals as required under Section 7.10, and complete, final as-built drawings as required under Section 7.11, all to City's satisfaction.

(C) **Acceptance.** The Project will be considered accepted upon City Council action during a public meeting to accept the Project, unless the Engineer is authorized to accept

the Project, in which case the Project will be considered accepted upon the date of the Engineer's issuance of a written notice of acceptance. In order to avoid delay of Project close out, the City may elect, acting in its sole discretion, to accept the Project as complete subject to exceptions for punch list items that are not completed within the time specified in the punch list.

(D) **Final Payment and Release of Retention.** Final Payment and release of retention, less any sums withheld pursuant to the provisions of the Contract Documents, will not be made sooner than 35 days after recordation of the notice of completion. If Contractor fails to complete all of the punch list items within the specified time, City may withhold up to 150% of City's estimated cost to complete each of the remaining items from Final Payment and may use the withheld retention to pay for the costs to self-perform the outstanding items or to retain a third party to complete any such outstanding punch list item.

11.2 Warranty.

(A) **General.** Contractor warrants that all materials and equipment will be new unless otherwise specified, of good quality, in conformance with the Contract Documents, and free from defective workmanship and materials. Contractor further warrants that the Work will be free from material defects not intrinsic in the design or materials required in the Contract Documents. Contractor warrants that materials or items incorporated into the Work comply with the requirements and standards in the Contract Documents, including compliance with Laws, and that any Hazardous Materials encountered or used were handled as required by Laws. At City's request, Contractor must furnish satisfactory evidence of the quality and type of materials and equipment furnished. Contractor's warranty does not extend to damage caused by normal wear and tear, or improper use or maintenance.

(B) **Warranty Period.** Contractor's warranty must guarantee its Work for a period of one year from the date of Project acceptance (the "Warranty Period"), except when a longer guarantee is provided by a supplier or manufacturer or is required by the Specifications or Special Conditions. Contractor must obtain from its Subcontractors, suppliers and manufacturers any special or extended warranties required by the Contract Documents.

(C) **Warranty Documents.** As a condition precedent to Final Completion, Contractor must supply City with all warranty and guarantee documents relevant to equipment and materials incorporated into the Work and guaranteed by their suppliers or manufacturers.

(D) **Subcontractors.** The warranty obligations in the Contract Documents apply to Work performed by Contractor and its Subcontractors, and Contractor agrees to be co-guarantor of such Work.

(E) **Contractor's Obligations.** Upon written notice from City to Contractor of any defect in the Work discovered during the Warranty Period, Contractor or its responsible Subcontractor must promptly correct the defective Work at its own cost. Contractor's obligation to correct defects discovered during the Warranty Period will continue past the expiration of the Warranty Period as to any defects in Work for which Contractor was notified prior to expiration of the Warranty Period. Work performed during the Warranty Period ("Warranty Work") will be subject to the warranty provisions in this Section 11.2 for a one-year period that begins upon completion of such Warranty Work to City's satisfaction.

(F) **City's Remedies.** If Contractor or its responsible Subcontractor fails to correct defective Work within ten days following notice by City, or sooner if required by the circumstances, City may correct the defects to conform with the Contract Documents at Contractor's sole expense. Contractor must reimburse City for its costs in accordance with subsection (H), below.

(G) **Emergency Repairs.** In cases of emergency where any delay in correcting defective Work could cause harm, loss or damage, City may immediately correct the defects to conform with the Contract Documents at Contractor's sole expense. Contractor or its surety must reimburse City for its costs in accordance with subsection (H), below.

(H) **Reimbursement.** Contractor must reimburse City for its costs to repair under subsections (F) or (G), above, within 30 days following City's submission of a demand for payment pursuant to this provision. If City is required to initiate legal action to compel Contractor's compliance with this provision, and City is the prevailing party in such action, Contractor and its surety are solely responsible for all of City's attorney's fees and legal costs expended to enforce Contractor's warranty obligations herein, in addition to any and all costs City incurs to correct the defective Work.

11.3 Use Prior to Final Completion. City reserves the right to occupy or make use of the Project, or any portions of the Project, prior to Final Completion if City has determined that the Project or portion of it is in a condition suitable for the proposed occupation or use, and that it is in its best interest to occupy or make use of the Project, or any portions of it, prior to Final Completion.

(A) **Non-Waiver.** Occupation or use of the Project, in whole or in part, prior to Final Completion will not operate as acceptance of the Work or any portion of it, nor will it operate as a waiver of any of City's rights or Contractor's duties pursuant to these Contract Documents, and will not affect nor bear on the determination of the time of substantial completion with respect to any statute of repose pertaining to the time for filing an action for construction defect.

(B) **City's Responsibility.** City will be responsible for the cost of maintenance and repairs due to normal wear and tear with respect to those portions of the Project that are being occupied or used before Final Completion. The Contract Price or the Contract Time may be adjusted pursuant to the applicable provisions of these Contract Documents if, and only to the extent that, any occupation or use under this Section actually adds to Contractor's cost or time to complete the Work within the Contract Time.

11.4 Substantial Completion. For purposes of determining "substantial completion" with respect to any statute of repose pertaining to the time for filing an action for construction defect, "substantial completion" is deemed to mean the last date that Contractor or any Subcontractor performs Work on the Project prior to City acceptance of the Project, except for warranty work performed under this Article.

Article 12 - Dispute Resolution

12.1 Claims. This Article applies to and provides the exclusive procedures for any Claim arising from or related to the Contract or performance of the Work.

(A) **Definition.** "Claim" means a separate demand by Contractor, submitted in writing by registered or certified mail with return receipt requested, for a change in the Contract Time, including a time extension or relief from liquidated damages, or a change in the Contract Price, when the demand has previously been submitted to City in accordance with the requirements of the Contract Documents, and which has been

rejected or disputed by City, in whole or in part. A Claim may also include that portion of a unilateral Change Order that is disputed by the Contractor.

(B) **Limitations.** A Claim may only include the portion of a previously rejected demand that remains in dispute between Contractor and City. With the exception of any dispute regarding the amount of money actually paid to Contractor as Final Payment, Contractor is not entitled to submit a Claim demanding a change in the Contract Time or the Contract Price, which has not previously been submitted to City in full compliance with Article 5 and Article 6, and subsequently rejected in whole or in part by City.

(C) **Scope of Article.** This Article is intended to provide the exclusive procedures for submission and resolution of Claims of any amount and applies in addition to the provisions of Public Contract Code § 9204 and § 20104 et seq., which are incorporated by reference herein.

(D) **No Work Delay.** Notwithstanding the submission of a Claim or any other dispute between the parties related to the Project or the Contract Documents, Contractor must perform the Work and may not delay or cease Work pending resolution of a Claim or other dispute, but must continue to diligently prosecute the performance and timely completion of the Work, including the Work pertaining to the Claim or other dispute.

(E) **Informal Resolution.** Contractor will make a good faith effort to informally resolve a dispute before initiating a Claim, preferably by face-to-face meeting between authorized representatives of Contractor and City.

12.2 Claims Submission. The following requirements apply to any Claim subject to this Article:

(A) **Substantiation.** The Claim must be submitted to City in writing, clearly identified as a "Claim" submitted pursuant to this Article 12 and must include all of the documents necessary to substantiate the Claim including the Change Order request that was rejected in whole or in part, and a copy of City's written rejection that is in dispute. The Claim must clearly identify and describe the dispute, including relevant references to applicable portions of the Contract Documents, and a chronology of relevant events. Any Claim for additional payment must include a complete, itemized breakdown of all known or estimated labor, materials, taxes, insurance, and subcontract, or other costs. Substantiating documentation such as payroll records, receipts, invoices, or the like, must be submitted in support of each component of claimed cost. Any Claim for an extension of time or delay costs must be substantiated with a schedule analysis and narrative depicting and explaining claimed time impacts.

(B) **Claim Format and Content.** A Claim must be submitted in the following format:

(1) Provide a cover letter, specifically identifying the submission as a "Claim" submitted under this Article 12 and specifying the requested remedy (e.g., amount of proposed change to Contract Price and/or change to Contract Time).

(2) Provide a summary of each Claim, including underlying facts and the basis for entitlement, and identify each specific demand at issue, including the specific Change Order request (by number and submittal date), and the date of City's rejection of that demand, in whole or in part.

(3) Provide a detailed explanation of each issue in dispute. For multiple issues included within a single Claim or for multiple Claims submitted concurrently, separately number and identify each individual issue or Claim, and include the following for each separate issue or Claim:

- a. A succinct statement of the matter in dispute, including Contractor's position and the basis for that position;
- b. Identify and attach all documents that substantiate the Claim, including relevant provisions of the Contract Documents, RFIs, calculations, and schedule analysis (see subsection (A), Substantiation, above);
- c. A chronology of relevant events; and
- d. Analysis and basis for claimed changes to Contract Price, Contract Time, or any other remedy requested.

(4) Provide a summary of issues and corresponding claimed damages. If, by the time of the Claim submission deadline (below), the precise amount of the requested change in the Contract Price or Contract Time is not yet known, Contractor must provide a good faith estimate, including the basis for that estimate, and must identify the date by which it is anticipated that the Claim will be updated to provide final amounts.

(5) Include the following certification, executed by Contractor's authorized representative:

"The undersigned Contractor certifies under penalty of perjury that its statements and representations in this Claim submittal are true and correct. Contractor warrants that this Claim submittal is comprehensive and complete as to the matters in dispute, and agrees that any costs, expenses, or delay not included herein are deemed waived."

(C) ***Submission Deadlines.***

(1) A Claim disputing rejection of a request for a change in the Contract Time or Contract Price must be submitted within 15 days following the date that City notified Contractor in writing that a request for a change in the Contract Time or Contract Price, duly submitted in compliance with Article 5 and Article 6, has been rejected in whole or in part. A Claim disputing the terms of a unilateral Change Order must be submitted within 15 days following the date of issuance of the unilateral Change Order. These Claim deadlines apply even if Contractor cannot yet quantify the total amount of any requested change in the Contract Time or Contract Price. If the Contractor cannot quantify those amounts, it must submit an estimate of the amounts claimed pending final determination of the requested remedy by Contractor.

(2) With the exception of any dispute regarding the amount of Final Payment, any Claim must be filed on or before the date of Final Payment or will be deemed waived.

(3) A Claim disputing the amount of Final Payment must be submitted within 15 days of the effective date of Final Payment, under Section 8.7, Final Payment.

(4) Strict compliance with these Claim submission deadlines is necessary to ensure that any dispute may be mitigated as soon as possible, and to facilitate cost-efficient administration of the Project. ***Any Claim that is not submitted within the specified deadlines will be deemed waived by Contractor.***

12.3 City's Response. City will respond within 45 days of receipt of the Claim with a written statement identifying which portion(s) of the Claim are disputed, unless the 45-day period is extended by mutual agreement of City and Contractor or as otherwise allowed under Public Contract Code § 9204. However, if City determines that the Claim is not adequately substantiated pursuant to Section 12.2(A), Substantiation, City may first request in writing, within 30 days of receipt of the Claim, any additional documentation supporting the Claim or relating to defenses to the Claim that City may have against the Claim.

(A) **Additional Information.** If additional information is thereafter required, it may be requested and provided upon mutual agreement of City and Contractor. If Contractor's Claim is based on estimated amounts, Contractor has a continuing duty to update its Claim as soon as possible with information on actual amounts in order to facilitate prompt and fair resolution of the Claim.

(B) **Non-Waiver.** Any failure by City to respond within the times specified above will not be construed as acceptance of the Claim, in whole or in part, or as a waiver of any provision of these Contract Documents.

12.4 Meet and Confer. If Contractor disputes City's written response, or City fails to respond within the specified time, within 15 days of receipt of City's response or within 15 days of City's failure to respond within the applicable 45-day time period under Section 12.3, respectively, Contractor may notify City of the dispute in writing sent by registered or certified mail, return receipt requested, and demand an informal conference to meet and confer for settlement of the issues in dispute. If Contractor fails to notify City of the dispute and demand an informal conference to meet and confer in writing within the specified time, Contractor's Claim will be deemed waived.

(A) **Schedule Meet and Confer.** Upon receipt of the demand to meet and confer, City will schedule the meet and confer conference to be held within 30 days, or later if needed to ensure the mutual availability of each of the individuals that each party requires to represent its interests at the meet and confer conference.

(B) **Location for Meet and Confer.** The meet and confer conference will be scheduled at a location at or near City's principal office.

(C) **Written Statement After Meet and Confer.** Within ten working days after the meet and confer has concluded, City will issue a written statement identifying which portion(s) of the Claim remain in dispute, if any.

(D) **Submission to Mediation.** If the Claim or any portion remains in dispute following the meet and confer conference, within ten working days after the City issues the written statement identifying any portion(s) of the Claim remaining in dispute, the Contractor may identify in writing disputed portion(s) of the Claim, which will be submitted for mediation, as set forth below.

12.5 Mediation and Government Code Claims.

(A) **Mediation.** Within ten working days after the City issues the written statement identifying any portion(s) of the Claim remaining in dispute following the meet and confer, City and Contractor will mutually agree to a mediator, as provided under Public Contract Code § 9204. Mediation will be scheduled to ensure the mutual availability of the selected mediator and all of the individuals that each party requires to represent its interests. If there are multiple Claims in dispute, the parties may agree to schedule the mediation to address all outstanding Claims at the same time. The parties will share the costs of the mediator and mediation fees equally, but each party is otherwise solely and separately

responsible for its own costs to prepare for and participate in the mediation, including costs for its legal counsel or any other consultants.

(B) **Government Code Claims.**

(1) Timely presentation of a Government Code Claim is a condition precedent to filing any legal action based on or arising from the Contract. Compliance with the Claim submission requirements in this Article 12 is a condition precedent to filing a Government Code Claim.

(2) The time for filing a Government Code Claim will be tolled from the time Contractor submits its written Claim pursuant to Section 12.2, above, until the time that Claim is denied in whole or in part at the conclusion of the meet and confer process, including any period of time used by the meet and confer process. However, if the Claim is submitted to mediation, the time for filing a Government Code Claim will be tolled until conclusion of the mediation, including any continuations, if the Claim is not fully resolved by mutual agreement of the parties during the mediation or any continuation of the mediation.

- 12.6 Tort Claims.** This Article does not apply to tort claims and nothing in this Article is intended nor will be construed to change the time periods for filing tort-based Government Code Claims.
- 12.7 Arbitration.** It is expressly agreed, under Code of Civil Procedure § 1296, that in any arbitration to resolve a dispute relating to this Contract, the arbitrator's award must be supported by law and substantial evidence.
- 12.8 Burden of Proof and Limitations.** Contractor bears the burden of proving entitlement to and the amount of any claimed damages. Contractor is not entitled to damages calculated on a total cost basis, but must prove actual damages. Contractor is not entitled to speculative, special, or consequential damages, including home office overhead or any form of overhead not directly incurred at the Project site or any other Worksite; lost profits; loss of productivity; lost opportunity to work on other projects; diminished bonding capacity; increased cost of financing for the Project; extended capital costs; non-availability of labor, material or equipment due to delays; or any other indirect loss arising from the Contract. The Eichleay Formula or similar formula will not be used for any recovery under the Contract. The City will not be directly liable to any Subcontractor or supplier.
- 12.9 Legal Proceedings.** In any legal proceeding that involves enforcement of any requirements of the Contract Documents, the finder of fact will receive detailed instructions on the meaning and operation of the Contract Documents, including conditions, limitations of liability, remedies, claim procedures, and other provisions bearing on the defenses and theories of liability. Detailed findings of fact will be requested to verify enforcement of the Contract Documents. All of the City's remedies under the Contract Documents will be construed as cumulative, and not exclusive, and the City reserves all rights to all remedies available under law or equity as to any dispute arising from or relating to the Contract Documents or performance of the Work.
- 12.10 Other Disputes.** The procedures in this Article 12 will apply to any and all disputes or legal actions, in addition to Claims, arising from or related to this Contract, including disputes regarding suspension or early termination of the Contract, unless and only to the extent that compliance with a procedural requirement is expressly and specifically waived by City. Nothing in this Article is intended to delay suspension or termination under Article 13.

Article 13 - Suspension and Termination

13.1 Suspension for Cause. In addition to all other remedies available to City, if Contractor fails to perform or correct Work in accordance with the Contract Documents, including non-compliance with applicable environmental or health and safety Laws, City may immediately order the Work, or any portion of it, suspended until the circumstances giving rise to the suspension have been eliminated to City's satisfaction.

(A) **Notice of Suspension.** Upon receipt of City's written notice to suspend the Work, in whole or in part, except as otherwise specified in the notice of suspension, Contractor and its Subcontractors must promptly stop Work as specified in the notice of suspension; comply with directions for cleaning and securing the Worksite; and protect the completed and in-progress Work and materials. Contractor is solely responsible for any damages or loss resulting from its failure to adequately secure and protect the Project.

(B) **Resumption of Work.** Upon receipt of the City's written notice to resume the suspended Work, in whole or in part, except as otherwise specified in the notice to resume, Contractor and its Subcontractors must promptly re-mobilize and resume the Work as specified; and within ten days from the date of the notice to resume, Contractor must submit a recovery schedule, prepared in accordance with the Contract Documents, showing how Contractor will complete the Work within the Contract Time.

(C) **Failure to Comply.** Contractor will not be entitled to an increase in the Contract Time or Contract Price for a suspension occasioned by Contractor's failure to comply with the Contract Documents.

(D) **No Duty to Suspend.** City's right to suspend the Work will not give rise to a duty to suspend the Work, and City's failure to suspend the Work will not constitute a defense to Contractor's failure to comply with the requirements of the Contract Documents.

13.2 Suspension for Convenience. City reserves the right to suspend, delay, or interrupt the performance of the Work in whole or in part, for a period of time determined to be appropriate for City's convenience. Upon notice by City pursuant to this provision, Contractor must immediately suspend, delay, or interrupt the Work and secure the Project site as directed by City except for taking measures to protect completed or in-progress Work as directed in the suspension notice, and subject to the provisions of Section 13.1(A) and (B), above. If Contractor submits a timely request for a Change Order in compliance with Articles 5 and 6, the Contract Price and the Contract Time will be equitably adjusted by Change Order pursuant to the terms of Articles 5 and 6 to reflect the cost and delay impact occasioned by such suspension for convenience, except to the extent that any such impacts were caused by Contractor's failure to comply with the Contract Documents or the terms of the suspension notice or notice to resume. However, the Contract Time will only be extended if the suspension causes or will cause unavoidable delay in Final Completion. If Contractor disputes the terms of a Change Order issued for such equitable adjustment due to suspension for convenience, its sole recourse is to comply with the Claim procedures in Article 12.

13.3 Termination for Default. City may declare that Contractor is in default of the Contract for a material breach of or inability to fully, promptly, or satisfactorily perform its obligations under the Contract.

(A) **Default.** Events giving rise to a declaration of default include Contractor's refusal or failure to supply sufficient skilled workers, proper materials, or equipment to perform the Work within the Contract Time; Contractor's refusal or failure to make prompt

payment to its employees, Subcontractors, or suppliers or to correct defective Work or damage; Contractor's failure to comply with Laws, or orders of any public agency with jurisdiction over the Project; evidence of Contractor's bankruptcy, insolvency, or lack of financial capacity to complete the Work as required within the Contract Time; suspension, revocation, or expiration and nonrenewal of Contractor's license or DIR registration; dissolution, liquidation, reorganization, or other major change in Contractor's organization, ownership, structure, or existence as a business entity; unauthorized assignment of Contractor's rights or duties under the Contract; or any material breach of the Contract requirements.

(B) **Notice of Default and Opportunity to Cure.** Upon City's declaration that Contractor is in default due to a material breach of the Contract Documents, if City determines that the default is curable, City will afford Contractor the opportunity to cure the default within ten days of City's notice of default, or within a period of time reasonably necessary for such cure, including a shorter period of time if applicable.

(C) **Termination.** If Contractor fails to cure the default or fails to expediently take steps reasonably calculated to cure the default within the time period specified in the notice of default, City may issue written notice to Contractor and its performance bond surety of City's termination of the Contract for default.

(D) **Waiver.** Time being of the essence in the performance of the Work, if Contractor's surety fails to arrange for completion of the Work in accordance with the Performance Bond within seven calendar days from the date of the notice of termination pursuant to paragraph (C), City may immediately make arrangements for the completion of the Work through use of its own forces, by hiring a replacement contractor, or by any other means that City determines advisable under the circumstances. Contractor and its surety will be jointly and severally liable for any additional cost incurred by City to complete the Work following termination, where "additional cost" means all cost in excess of the cost City would have incurred if Contractor had timely completed Work without the default and termination. In addition, City will have the right to immediate possession and use of any materials, supplies, and equipment procured for the Project and located at the Project site or any Worksite on City property for the purposes of completing the remaining Work.

(E) **Compensation.** Within 30 days of receipt of updated as-builts, all warranties, manuals, instructions, or other required documents for Work installed to date, and delivery to City of all equipment and materials for the Project for which Contractor has already been compensated, Contractor will be compensated for the Work satisfactorily performed in compliance with the Contract Documents up to the effective date of the termination pursuant to the terms of Article 8, Payment, subject to City's rights to withhold or deduct sums from payment otherwise due pursuant to Section 8.3, and excluding any costs Contractor incurs as a result of the termination, including any cancellation or restocking charges or fees due to third parties. If Contractor disputes the amount of compensation determined by City, its sole recourse is to comply with the Claim Procedures in Article 12, by submitting a Claim no later than 30 days following notice from City of the total compensation to be paid by City.

(F) **Wrongful Termination.** If Contractor disputes the termination, its sole recourse is to comply with the Claim procedures in Article 12. If a court of competent jurisdiction or an arbitrator later determines that the termination for default was wrongful, the termination will be deemed to be a termination for convenience, and Contractor's damages will be strictly limited to the compensation provided for termination for convenience under Section 13.4, below. Contractor waives any claim for any other damages for wrongful termination including special or consequential damages, lost

opportunity costs, or lost profits, and any award of damages is subject to Section 12.8, Burden of Proof and Limitations.

13.4 Termination for Convenience. City reserves the right, acting in its sole discretion, to terminate all or part of the Contract for convenience upon written notice to Contractor.

(A) **Compensation to Contractor.** In the event of City's termination for convenience, Contractor waives any claim for damages, including for loss of anticipated profits from the Project. The following will constitute full and fair compensation to Contractor, and Contractor will not be entitled to any additional claim or compensation:

(1) *Completed Work.* The value of its Work satisfactorily performed as of the date notice of termination is received, based on Contractor's schedule of values and unpaid costs for items delivered to the Project site that were fabricated for incorporation in the Work;

(2) *Demobilization.* Demobilization costs specified in the schedule of values, or if demobilization costs were not provided in a schedule of values pursuant to Section 8.1, then based on actual, reasonable, and fully documented demobilization costs; and

(3) *Termination Markup.* Five percent of the total value of the Work performed as of the date of notice of termination, including reasonable, actual, and documented costs to comply with the direction in the notice of termination for convenience, and demobilization costs, which is deemed to cover all overhead and profit to date.

(B) **Disputes.** If Contractor disputes the amount of compensation determined by City pursuant to paragraph (A), above, its sole recourse is to comply with the Claim procedures in Article 12, by submitting a Claim no later than 30 days following notice from City of total compensation to be paid by City.

13.5 Actions Upon Termination for Default or Convenience. The following provisions apply to any termination under this Article, whether for default or convenience, and whether in whole or in part.

(A) **General.** Upon termination, City may immediately enter upon and take possession of the Project and the Work and all tools, equipment, appliances, materials, and supplies procured or fabricated for the Project. Contractor will transfer title to and deliver all completed Work and all Work in progress to City.

(B) **Submittals.** Unless otherwise specified in the notice of termination, Contractor must immediately submit to City all designs, drawings, as-built drawings, Project records, contracts with vendors and Subcontractors, manufacturer warranties, manuals, and other such submittals or Work-related documents required under the terms of the Contract Documents, including incomplete documents or drafts.

(C) **Close Out Requirements.** Except as otherwise specified in the notice of termination, Contractor must comply with all of the following:

(1) Immediately stop the Work, except for any Work that must be completed pursuant to the notice of termination and comply with City's instructions for cessation of labor and securing the Project and any other Worksite(s).

(2) Comply with City's instructions to protect the completed Work and materials, using best efforts to minimize further costs.

(3) Contractor must not place further orders or enter into new subcontracts for materials, equipment, services or facilities, except as may be necessary to complete any portion of the Work that is not terminated.

(4) As directed in the notice, Contractor must assign to City or cancel existing subcontracts that relate to performance of the terminated Work, subject to any prior rights, if any, of the surety for Contractor's performance bond, and settle all outstanding liabilities and claims, subject to City's approval.

(5) As directed in the notice, Contractor must use its best efforts to sell any materials, supplies, or equipment intended solely for the terminated Work in a manner and at market rate prices acceptable to City.

(D) **Payment Upon Termination.** Upon completion of all termination obligations, as specified herein and in the notice of termination, Contractor will submit its request for Final Payment, including any amounts due following termination pursuant to this Article 13. Payment will be made in accordance with the provisions of Article 8, based on the portion of the Work satisfactorily completed, including the close out requirements, and consistent with the previously submitted schedule of values and unit pricing, including demobilization costs. Adjustments to Final Payment may include deductions for the cost of materials, supplies, or equipment retained by Contractor; payments received for sale of any such materials, supplies, or equipment, less re-stocking fees charged; and as otherwise specified in Section 8.3, Adjustment of Payment Application.

(E) **Continuing Obligations.** Regardless of any Contract termination, Contractor's obligations for portions of the Work already performed will continue and the provisions of the Contract Documents will remain in effect as to any claim, indemnity obligation, warranties, guarantees, submittals of as-built drawings, instructions, or manuals, record maintenance, or other such rights and obligations arising prior to the termination date.

Article 14 - Miscellaneous Provisions

- 14.1 Assignment of Unfair Business Practice Claims.** Under Public Contract Code § 7103.5, Contractor and its Subcontractors agree to assign to City all rights, title, and interest in and to all causes of action it may have under section 4 of the Clayton Act (15 U.S.C. § 15) or under the Cartwright Act (Chapter 2 (commencing with § 16700) of Part 2 of Division 7 of the Business and Professions Code), arising from purchases of goods, services, or materials pursuant to the Contract or any subcontract. This assignment will be effective at the time City tenders Final Payment to Contractor, without further acknowledgement by the parties.
- 14.2 Provisions Deemed Inserted.** Every provision of law required to be inserted in the Contract Documents is deemed to be inserted, and the Contract Documents will be construed and enforced as though such provision has been included. If it is discovered that through mistake or otherwise that any required provision was not inserted, or not correctly inserted, the Contract Documents will be deemed amended accordingly.
- 14.3 Waiver.** City's waiver of a breach, failure of any condition, or any right or remedy contained in or granted by the provisions of the Contract Documents will not be effective unless it is in writing and signed by City. City's waiver of any breach, failure, right, or remedy will not be deemed a waiver of any other breach, failure, right, or remedy, whether or not similar, nor will any waiver constitute a continuing waiver unless specified in writing by City.

- 14.4 Titles, Headings, and Groupings.** The titles and headings used and the groupings of provisions in the Contract Documents are for convenience only and may not be used in the construction or interpretation of the Contract Documents or relied upon for any other purpose.
- 14.5 Statutory and Regulatory References.** With respect to any amendments to any statutes or regulations referenced in these Contract Documents, the reference is deemed to be the version in effect on the date that bids were due.
- 14.6 Survival.** The provisions that survive termination or expiration of this Contract include Contract Section 11, Notice, and subsections 12.1, 12.2, 12.3, 12.4, 12.5, and 12.6, of Section 12, General Provisions; and the following provisions in these General Conditions: Section 2.2(J), Contractor's Records, Section 2.3(C), Termination, Section 3.7, Ownership, Section 4.2, Indemnity, Article 12, Dispute Resolution, and Section 11.2, Warranty.

END OF GENERAL CONDITIONS

Special Conditions

1. Authorized Work Days and Hours.
 - 1.1 **Authorized Work Days.** Except as expressly authorized in writing by City, Contractor is limited to performing Work on the Project on the following days of the week, excluding holidays observed by City:
Monday through Friday
 - 1.2 **Authorized Work Hours.** Except as expressly authorized in writing by City, Contractor is limited to performing Work on the Project during the following hours: Monday through Friday 8:00 a.m. to 6:00 p.m. A schedule of work shall be submitted to the City for review and approval prior to mobilization to the site work.

- 2 Pre-Construction Conference. City will designate a date and time for a pre-construction conference with Contractor following Contract execution. Project administration procedures and coordination between City and Contractor will be discussed, and Contractor must present City with the following information or documents at the meeting for City's review and acceptance before the Work commences:
 - 2.1 Name, 24-hour contact information, and qualifications of the proposed on-site superintendent;
 - 2.2 List of all key Project personnel and their complete contact information, including email addresses and telephone numbers during regular hours and after hours;
 - 2.3 Staging plans that identify the sequence of the Work, including any phases and alternative sequences or phases, with the goal of minimizing the impacts on residents, businesses and other operations in the Project vicinity;
 - 2.4 If required, traffic control plans associated with the staging plans that are signed and stamped by a licensed traffic engineer;
 - 2.5 Draft baseline schedule for the Work as required under Section 5.2, to be finalized within ten days after City issues the Notice to Proceed;
 - 2.6 Breakdown of lump sum bid items, to be used for determining the value of Work completed for future progress payments to Contractor;
 - 2.7 Schedule with list of Project submittals that require City review, and list of the proposed material suppliers;
 - 2.8 Plan for coordination with affected utility owner(s) and compliance with any related permit requirements;
 - 2.9 Videotape and photographs recording the conditions throughout the pre-construction Project site, showing the existing improvements and current condition of the curbs, gutters, sidewalks, signs, landscaping, streetlights, structures near the Project such as building faces, canopies, shades and fences, and any other features within the Project area limits;
 - 2.10 If requested by City, Contractor's cash flow projections; and

2.11 Any other documents specified in the Special Conditions or Notice of Potential Award.

3. Insurance Requirements. The insurance requirements under Section 4.3 of the General Conditions are modified for this Contract, as set forth below. Except as expressly stated below, all other provisions in Section 4.3 are unchanged and remain in full force and effect.

3.1 **Builders Risk Insurance Waived.** The builder's risk insurance policy requirement set forth in subsection 4.3(A)(5) of the General Conditions is hereby waived and does not apply to this Contract.

4. Normal Weather Delay Days. This provision is intended to supplement the requirements of General Conditions Section 5.2 on Schedule Requirements and Section 5.3 on Delays and Extensions of Contract Time. Based on historic records for the Project location, Contractor's schedule should assume the following number of normal Weather Delay Days for each month:

Month	# Normal Weather Delay Days
January	6
February	5
March	2
April	2
May	0
June	0
July	0
August	0
September	0
October	1
November	1
December	5

Weather Delay Days which do not occur during a given month based on the number of days allocated for that month (above) do not carry over to another month.

5. Public Notification.

5.1 At least seventy-two (72) hours prior to the start of work that will affect property access, wastewater flow, parking, or traffic circulation, the Contractor shall provide notice to affected homeowners of the impending construction activity.

5.2 The contractor shall designate a representative to address questions and comments from the general public in the area and make an effort to reach out to the adjacent residents before and during the construction. The cost of this outreach shall be included in various items necessary to complete the work as stated in the contract and no additional compensation will be made for this coordination effort.

6. Alterations

The City reserves the right to increase or decrease the quantity of any item or portion of the Work or omit portions of the Work as may be deemed necessary or advisable by the City Engineer; also, to make such alterations or deviations, additions to, or omissions from the Plans and

Special Provisions, as may be determined during the progress of the Work to be necessary and advisable for the proper completion thereof. Upon written order of the Engineer, the Contractor shall proceed with the Work as increased, decreased or altered.

Increases or Decreases in the Quantity of Work: The contractor is not entitled to adjustments of the unit price if the total bid item quantity exceeds 125 percent shown on the bid item list. The contractor is not entitled to adjustments of the unit price if the total bid item quantity is less than 75 percent shown on the bid item list.

7. Close Out Requirements. Contractor's close out requirements include the following, if applicable:

- 7.1** Contractor must replace, with thermoplastic, any existing striping adjacent to the Project site that is damaged during the Work. Partially damaged striping must be replaced in its entirety.
- 7.2** Contractor must replace any survey monuments that are damaged or removed during the Work, with a Record of Survey filed by a licensed land surveyor as required by California law.

8. Value Engineering. The Contractor may be entitled to additional compensation for cost reduction changes made pursuant to a value engineering proposal submitted by the Contractor, subject to the limitations of Public Contract Code § 7107, and in strict compliance with this Section 8. Contractor will not be entitled to any such additional compensation unless all of the following requirements have been met:

- 8.1** The Contractor must submit a written proposal for changes to the Plans or Specifications for the Project, in which it:
 - (A) Identifies the written proposal as a proposal for cost reduction changes with reference to this section;
 - (B) Clearly and specifically identifies the proposed cost reduction changes by describing in detail each of the changes proposed with specific references to each of the Specifications and Plans involved in the proposed changes, and providing proposed revised Specifications and Plans as applicable; and
 - (C) Estimates the net amount of the cost reduction and provides the basis for that estimate.
- 8.2** The proposed changes have been identified and developed solely by the Contractor, and not, in whole or in part, by the City.
- 8.3** The City accepts the proposed changes in whole or in part in a writing signed by the Engineer. The Contractor will only be entitled to additional compensation for those changes specifically accepted by the City. The Engineer will determine the net savings in construction costs from any such changes that are both accepted and implemented by the City. Contractor will not be entitled to more than 50% of the net savings as determined by the Engineer, acting in his or her sole discretion.

END OF SPECIAL CONDITIONS

TECHNICAL SPECIFICATIONS

These Specifications were prepared under the direction of:

Richard Souza, PE
Project Engineer
CSW | ST2
415.533.1864
richs@cswst2.com

DESCRIPTION OF BID ITEMS

SECTION 10-1 – MOBILIZATION / DEMOBILIZATION

10-1.01 GENERAL

Mobilization shall conform to the provisions in Section 9-1.16(D), "Mobilization," of the State Standard Specifications, and shall consist of preparatory work and operations including, but not limited to, those necessary for the movement of personnel, equipment, supplies incidental to the project site, for the establishment of all staging areas and other facilities necessary for work on the project and for all other work and operations which must be performed or for project costs incurred prior to beginning work on the various Contract items. Mobilization shall include obtaining insurance and bonds, obtaining and paying for all permits by other agencies if applicable, furnishing temporary construction utilities, installing construction and other construction facilities all as required for the proper performance and completion of the work.

The work of this bid item also includes demobilization. Demobilization shall include final cleaning and restoration of the job site, removal of all temporary facilities and equipment from the work area, disconnection of the temporary construction utilities and turnover of project to the City.

10-1.02 MEASUREMENT AND PAYMENT

Full compensation for completing the requirements of this section shall be considered as included in the lump sum price paid for "Mobilization / Demobilization" (Bid Item 1).

Partial payments for Mobilization / Demobilization shall not exceed the following:

- (1) When 5 percent of the original contract amount is earned, 50 percent of the amount bid for Mobilization, or 5 percent of the original contract amount, whichever is lesser, may be paid.
- (2) When 10 percent of the original contract amount is earned, 75 percent of the amount bid for Mobilization or 7.5 percent of the original contract amount, whichever is lesser, may be paid.
- (3) When 20 percent of the original contract amount is earned, 95 percent of the amount bid for Mobilization, or 9.5 percent of the original contract amount, whichever is lesser, may be paid.
- (4) When 50 percent of the original contract amount is earned, 100 percent of the amount bid for mobilization, or 10 percent of the original contract amount, whichever is lesser, may be paid.
- (5) Upon completion of all work on the project, (including: punch list items, cleaning up and removal of all temporary facilities and equipment from the project site) payment of any amount bid for Mobilization in excess of 10 percent of the original contract amount will be paid.

SECTION 10-2 – CONSTRUCTION PHASING AND TRAFFIC CONTROL

10-2.01 GENERAL

The Contractor shall implement and maintain a temporary traffic control system in accordance with Section 12 "Temporary Traffic Control" of the Standard Specifications to provide safe access for motorists, pedestrians, bicyclists, and transit through the work zone. The traffic control system shall be implemented in phases in accordance with the Contractor's proposed construction sequencing plan as defined in the Special Conditions. This traffic control system shall include, but is not limited to, the following:

- Development of traffic control plans consistent with the contractor's intended phasing of construction.
- Implementation of a traffic control system for various traffic situations and street configurations in full conformance with the "California Manual on Uniform Traffic Control Devices 2014 ((Federal Highway Administration (FHWA) Manual of Uniform Traffic Control Devices (MUTCD) 2009, as amended for use in California)" herein after referred to as Traffic Control Manual.
- Provision of temporary facilities to accommodate accessible pedestrian pathways through the project area and to access all properties within the work zone.

10-2.02 SUBMITTALS

The Contractor shall provide submittals for the following:

- Construction Phasing - The Contractor shall prepare a sequence of work to complete the project as described in the Special Conditions section of these Special Provisions.
- Traffic Control Plans - The Contractor shall submit traffic handling plans for each phase of the project. The plans shall be at a scale no less than 1 inch = 40 feet and shall clearly illustrate traffic control devices consistent with the Traffic Control Manual for vehicles, pedestrians, bicyclist, and transit. These plans shall clearly illustrate how pedestrians are routed through the work zone through an ADA compliant path of travel. In addition, the plans shall illustrate no parking zones. The Contractor shall revise the plans as required by the Engineer.
- Project Information Signs - Contractor shall submit Construction Information Sign format and content to the Engineer that includes the following:
 1. Name of project
 2. Name of 24/7 contact name and number for contractor
 3. City contact name and number
 4. Funding Sources
 5. Starting and completion dates of the contract.

10-2.03 EXECUTION

CHANGEABLE MESSAGE SIGNS

At least four (4) changeable message signs shall be made available during the project, as requested by the Engineer and shall remain in service for as long as construction is in effect. The changeable message sign shall be a pull-type, solar-powered LED sign. The Engineer may request that the Contractor install the signs outside of the City's limits.

CONSTRUCTION AREA SIGNS

Once construction starts, the Contractor shall furnish and install construction area signs to inform motorists, pedestrians, and bicyclists of work in the streets and sidewalks. These signs may include, but are not limited to, "Road Construction Ahead", "Detour Ahead", "Road Closed". Construction area signs shall be furnished, installed, maintained, and removed when no longer required in accordance with the provisions in Section 12, "Temporary Traffic Control Devices" of the Standard Specifications and these Technical Specifications.

Construction area signs shall be metal, with reflective coating, black on orange, and securely mounted. Signs shall be kept clean and in good repair. The Contractor's traffic control plan shall show the location of the signs.

The Contractor shall be responsible for providing, placing, and installing all construction area signs. The signs shall not be installed on trees, utility poles, private property, or any other appurtenance, unless approved by the Engineer.

10-2.04 MEASUREMENT AND PAYMENT

The contract lump sum price paid for "Construction Phasing and Traffic Management" (**Bid Item 2**) includes full compensation for furnishing all labor, materials, tools, equipment, and incidentals, and for doing all the work involved in providing a traffic control system, complete in place, as shown on the Plans, as specified in the Standard Specifications, these Specifications, and as directed by the Engineer.

The Contractor shall be paid on pro rata basis for the work done per month, and said payment shall be for providing all labor, material, equipment, devices, supervision, and all incidentals as are needed to provide traffic control as specified herein, and as may be required to complete the work.

SECTION 10-3 – WATER POLLUTION CONTROL

10-3.01 GENERAL

The Contractor shall be responsible for implementing and managing these systems during the life of the project. The SPCP shall conform to all applicable requirements in Section 13-2, "Water Pollution Control," of the State Standard Specifications these Special Provisions, Section 30, Stormwater Pollution Control.

10-3.02 SUBMITTAL

The Contractor shall submit a **Water Pollution Control Program (WPCP)** to address the storm drain and various improvements to the Engineer for approval. The WPCP shall conform to the Section 13 Water Pollution Control of the Standard Specifications and these Specifications.

10-3.03 EXECUTION

The WPCP shall be prepared using the latest template posted on the State's Construction stormwater website.

Dewatering work shall comply with Section 13-4 Job Site Management of the Standard Specifications and shall include the following:

1. Keep all excavations reasonably free from water during construction.
2. Disposal of water shall not damage property or create a public nuisance.
3. Have on hand pump equipment and machinery in good working condition for emergencies and workmen available for its operation.
4. Dewatering systems shall operate continuously until foundations are poured or trenches are backfilled.
5. Groundwater shall be controlled to prevent softening of the bottom of excavations, or formation of "quick" conditions.
6. Dewatering systems shall not remove natural soils.
7. Control surface runoff to prevent entry or collection of water excavations.
8. Release of groundwater shall be controlled to prevent disturbance of the natural foundation soils or compact fill.
9. There shall be no discharge of turbid water on site.
10. Discharge or disposal of water shall be controlled to prevent erosion

The Contractor shall not perform work that may cause water pollution until the WPCP has been approved by the Engineer. The Engineer's review and approval shall not waive any contract requirements and shall not relieve the Contractor from complying with Federal, State and local laws, regulations, and requirements.

10-3.04 MEASUREMENT AND PAYMENT

The contract lump sum price paid for "Water Pollution Control" (**Bid Item 3**) includes full compensation for furnishing all labor, materials, tools, equipment, and incidentals, and for doing all the work involved in implementation and maintenance of the water pollution prevention system, complete in place, as shown on the Plans, as specified in the Standard Specifications, these Specifications, and as directed by the Engineer.

SECTION 10-4 – CONSTRUCTION LAYOUT

10-4.01 GENERAL

This section specifies the work for construction staking which consists of providing all labor, tools, equipment, materials and incidentals necessary to locate by staking all improvements, to the line and grade shown on the Plans.

10-4.02 EXECUTION

Contractor shall furnish all land surveys, establish all base lines and bench marks and make sufficient detailed surveys needed for working points, lines and elevations. The Contractor shall develop all batter boards. Contractor shall also develop all additional working points, lines and elevations as they may desire to facilitate his or her methods and sequence of construction.

All work shall be staked in order to meet the lines and grades shown on the Plans. Copies of all survey cut sheets shall be provided to the City Engineer two (2) working days before the planned work begins.

Prior to concrete pouring, formwork and survey staking shall be reviewed and approved by the City Engineer.

10-4.03 MEASUREMENT AND PAYMENT

The contract lump sum price paid for “Construction Layout” (**Bid Item 4**) includes full compensation for furnishing all labor, materials, tools, equipment, and incidentals, and for doing all the work involved in providing staking and layout, complete in place, as shown on the Plans, as specified in the Standard Specifications, these Specifications, and as directed by the Engineer.

SECTION 10-5 – UTILITY POTHOLING

10-5.01 GENERAL

The Contractor shall make their own investigations, including exploratory excavations, referenced herein as potholing, to determine the locations and type of existing utilities, including service connections, prior to commencing work which may result in damage to existing utilities or other underground facilities. .

It is not the intent of the Plans to show the exact location of all existing or relocated utilities and the Engineer assumes no responsibility therefor. The position of the utilities shown on the Plans is derived from records of utility owners and limited utility locating services. The service connections to these utilities may be, but are not necessarily, shown on the drawings. Overhead utilities including wires, poles and guys are not necessarily shown on the Plans and shall be determined from the Contractor's visit to the site. It shall be the responsibility of the Contractor to determine the exact location of all utilities and service connections thereto ahead of any excavations through "potholing." The Contractor shall immediately notify the Engineer as to any utility discovered by him/her in a different position than shown on the drawings or which is not shown on the drawings.

10-5.02 EXECUTION

Prior to setting grades or commencing any excavation work, the Contractor shall contact all affected utility owners and request them to locate and mark the location of their respective utilities on the ground. The Contractor shall then undertake "potholing" procedures as described herein below.

Methodology for potholing shall be determined by location and shall be approved by the Engineer prior to starting work. Potholing methodology shall not disturb surrounding facilities, pavements, structures, vegetation, or other existing elements beyond what is necessary for the potholing location.

If a utility owner is not equipped to provide the locating service, the Contractor shall provide for it. The location of said underground pipes and conduits shall be clearly marked on the pavement or with suitable markers if not on pavement. In addition to the location of metallic pipes and conduits, non-metallic pipe, ducts and conduits shall also be similarly located using surface indicators and shall then be similarly marked.

As soon as the utility survey is completed, and prior to setting grades or commencing fabrication of engineered pipe, the Contractor shall commence "potholing" to determine the actual location of the pipe, duct or conduit. The Contractor shall uncover all underground utilities, including sewers and storm drains, exercising extreme care so as to avoid drainage. It will be the Contractor's responsibility to have repairs made to existing facilities at their expense in the event of damage. Underground utilities shall be uncovered to a point one (1) foot below the pipe or as directed by the Engineer, where crossing, interferences or connections are shown on the drawings, prior to the preparation of shop drawings, trenching or excavating for any pipe or structure, in order to determine actual elevations. Once uncovered, the Contractor shall record the depth of the utility at the pothole and clearly mark the depth on the pavement. Any variation in the actual elevations and the indicated elevations shall be brought to the Engineer's attention.

Excavations around underground electrical ducts and conduits shall be performed using extreme caution to prevent injury or damage to workers and the electrical ducts or conduits. Similar precautions shall be exercised around gas line, telephone, and television cables.

Where an underground utility is at variance with the Plans the contractor shall proceed as follows:

- A. Marked utility not shown on the Plans: If a utility is not shown on the Plans but marked in the field by the utility owner, the Contractor shall pothole the utility and proceed with the work providing the utility is not in conflict with the line or grade of the pipeline to be laid and report the discrepancy to the Engineer.
- B. Utility shown on the Plans but not marked: If a utility is shown on the Plans, but not marked by the utility company or marked in a different location, then the Contractor shall consult with the utility company, pothole the utility, and then proceed with the work providing the utility is not in conflict with the foundation or grade of the pipeline to be laid.
- C. Unmarked utility: If a utility is not marked by the utility company and the contractor encounters it, then the contractor shall immediately notify the Engineer and the utility company. The Contractor shall proceed with the work if the utility is not in conflict with the line or grade of the pipeline to be installed.

After the need for potholing is complete, the Contractor shall backfill the potholing location.

10-5.03 MEASUREMENT AND PAYMENT

Full compensation for providing "Utility Potholing" shall include furnishing all labor, materials, tools, equipment, and incidentals, and for doing all the work as shown on the Plans, as specified in the Standard Specifications and these Specifications, and as directed by the Engineer and shall be considered as included in the contract prices for the various items of work and no additional compensation will be made therefor.

SECTION 10-6 – MONUMENT PRESERVATION

10-6.01 GENERAL

The Contractor shall preserve monuments, benchmarks, survey control points, reference points, and other permanent points (hereinafter referred to as monuments) in accordance with the Business & Professions Code §8771; Streets & Highways §732 & §732.5, §1492.5, §1810.5; and Penal Code §605. The Plans indicate the locations of all known monuments located within the project area. All work locating and setting monuments shall be completed by a Land Surveyor licensed by the State of California.

The Engineer has filed corner records for all survey monuments within the project area. Prior to commencement of construction, the Engineer will provide this map to the Contractor. The Contractor shall preserve these features to the extent that is practical. Prior to disturbing a monument, the Contractor shall notify the Engineer.

The Contractor shall assume at least ten (10) monuments will need to be relocated and reset.

10-6.02 EXECUTION

The Contractor shall locate all monuments within the project area that could potentially be disturbed by his or her work. For each of these monuments, the Contractor shall file a pre-construction corner record with Marin County showing three reference control points that are tied to the monument. **NO WORK CAN COMMENCE UNTIL THIS IS COMPLETE.**

If a monument is disturbed, the Contractor shall re-set the monument in accordance with Uniform Construction Standard Drawing #300 and file a corner record with Marin County. The Contractor shall be responsible for paying the cost for all filing fees.

In the event that any non-referenced monuments or monument reference points become in danger of being disturbed due to construction, the Contractor shall cease the threatening activity and notify the Engineer immediately. In no case may an unreferenced monument or monument reference point be damaged during construction.

Any monuments that are disturbed or sustain damage during construction, the Contractor shall bear the expense for rebuilding it. In any instance where the City deems a damaged monument to be irreplaceable, the Contractor shall be fined \$20,000 per monument.

10-6.03 MEASUREMENT AND PAYMENT

Full compensation for providing “Monument Preservation” includes furnishing all labor, materials, tools, equipment, and incidentals, and for doing all the work involved in preserving monuments, including filing records and resetting points, complete in place, as shown on the Plans, as specified in the Standard Specifications, these Specifications, and as directed by the Engineer and shall be considered as included in the contract prices for the various items of work and no additional compensation will be made therefor.

SECTION 10-7 – CLEARING AND GRUBBING AND REMOVALS

10-7.01 GENERAL

All clearing and grubbing work shall be done in accordance with Section 10-2, "Clearing and Grubbing", of the State Standard Specifications, these Specifications, and as directed by the Engineer.

10-7.02 EXECUTION

Clearing and grubbing shall consist of, but not limited to, removing and disposing of vegetation, debris, soil, trees less than 6-inches in diameter, roots, pavement, and all other objectionable material as required to construct the improvements, as shown on the Plans and as specified in these Specifications.

Plant removal, as indicated in the plans shall include removal of any roots or trunks to a depth of fifteen (15) inches below existing grade or as directed by the Engineer.

The Contractor shall dispose all excess materials consistent with Section 11 "Disposal" of the Special Conditions.

Prior to starting clearing and grubbing operations, the Contractor shall inform the Engineer of the intended limits of their clearing and grubbing operations and shall obtain the Engineer's approval on such proposed limits. The Contractor shall not clear and grub any area not essential to their construction obligations and protect from injury or damage resulting from their operations all vegetation, facilities, or improvements, which are to remain. All edges of existing paving to remain shall be sawcut in a neat, clean manner.

10-7.03 MEASUREMENT AND PAYMENT

The unit paid for "Clearing and Grubbing and Removals" (**Bid Item 5**) includes full compensation for furnishing all labor, materials, tools, equipment, and incidentals, and for doing all the work involved in site clearing, complete in place, including disposal, as shown on the plans, as specified in the Standard Specifications and these Specifications, and as directed by the Engineer.

SECTION 10-8 – DEMOLITION

10-8.01 GENERAL

Demolition work shall consist of and include all demolition, sawcutting, removals, salvaging, and stockpiling, including concrete pavement, asphalt pavement, signs, and other miscellaneous demolition as shown on the Plans or specified herein. The Contractor shall provide tree protection as indicated in the Specifications and Plans. The Contractor shall obtain all special permits and licenses and give all notices required for performance and completion of the demolition and removal work, hauling, and disposal of debris.

Contractor shall review with City's Representative the exact limits of work and extent of materials to be removed.

- A. Examine site and structures and determine exact nature and status of structural elements and above ground and below ground utilities prior to commencing demolition.
- B. City assumes no responsibility for actual condition of items or structures to be demolished.
- C. Prior to commencing the work, perform a site survey to identify existing areas of damage to adjacent building areas and other buildings.

10-8.02 SUBMITTALS

Contractor shall submit a schedule indicating proposed methods and sequence of operations for selective demolition work for review prior to commencement of work. Include coordination for shut-off, capping, and continuation of utility services as required.

- A. Provide detailed sequence of demolition and removal work to ensure uninterrupted progress of adjacent building uses.
- B. Coordinate continued occupancy with adjacent building tenants.

10-8.03 EXECUTION

Standards

All work shall conform to ANSI A10.6, Safety Requirements for Demolition Operations and to the codes and regulations of the City.

Attention is also directed to Section 15, "Existing Facilities," of the State Standard Specifications.

Concrete removal work shall be done in accordance with Section 15-1.03B, "Removing Concrete", of the Standard Specifications, these Specifications, the Contract Plans and as directed by the Engineer.

Residue from cutting operations shall not be permitted to flow into storm drains or across lanes occupied by traffic and shall be removed from the pavement surface, concurrent with the cutting operation. All excavated material shall be removed and disposed of outside the street right of way in accordance with relevant sections of the State Standard Specifications.

Dust Control shall conform to the provisions of Section 10-5, "Dust Control" of the State Standard Specifications.

The Contractor shall receive no additional compensation for delays or inconvenience caused by utility relocations and/or adjustments. The delay caused by these relocations and/or adjustments shall not count towards the Contractors' "working days."

The Contractor shall dispose all excess materials consistent with Section 11 "Disposal" of the Special Conditions.

Provide a minimum of 72 hours advance notice of demolition activities to the Engineer.

Protection: Provide temporary barricades and other forms of protection as required to protect the general public from injury due to selective demolition work. Provide protective measures as required to provide free and safe passage of general public to and from occupied portions of building. Erect temporary covered passageways as required by authorities having jurisdiction.

Environmental Controls: Use water sprinkling, temporary enclosures, and other suitable methods to limit dust and dirt rising and scattering in air to lowest practical level. Comply with governing regulations pertaining to environmental protection.

Utilities: The Contractor shall call USA at (800) 642-2444 to mark the locations of all underground utilities at least 48 hours before the intended start of excavation. Any damage to any utility due to the Contractor's operations shall be repaired or replaced by the Contractor to the satisfaction of the Engineer.

Affected utility companies include but may not be limited to:

- A. Pacific Gas & Electric Company
- B. AT&T
- C. Comcast
- D. Marin Municipal Utility District
- E. City of Sausalito storm drain, electrical, traffic signal, and sanitary sewer

The Contractor is responsible for coordinating with the various utility agencies for lateral adjustment and/or relocation.

Contractor shall protect active sewer, water, gas, electric, and other utilities; and drainage and irrigation lines indicated or, when not indicated, found or otherwise made known to the Contractor before or during demolition work.

Selective Demolition: Perform selective demolition work in a systematic manner. Use methods required to complete work indicated on the Plans in accordance with demolition schedule and governing regulations. Conduct selective demolition operations and debris removal in a manner to ensure minimum interference with roads, streets, walks, and other adjacent occupied or used facilities.

Traffic: Do not close, block or otherwise obstruct streets, walks, or other occupied or used facilities without written permission from the Engineer. Provide alternate routes around closed or obstructed traffic ways if required by governing regulations.

Clean up: The Contractor shall perform daily cleanup operations to keep the job site and adjacent properties free from accumulation of waste materials and debris resulting from the Contractor's operations. The Contractor shall deposit waste material in on-site containers or at a legal disposal area away from the site at the end of each working day.

Nothing herein shall be construed as relieving the Contractor of their responsibility for final cleanup of the site as provided in Section 4-1.13, "Cleanup", of the Standard Specifications.

Damages: Promptly repair damages caused to adjacent facilities by demolition work at no cost to the City.

Contractor Salvage: Items indicated on the Plans as to be removed but of salvageable value to the Contractor may be removed from site as work progresses. Contractor shall transport such items from site as they are removed. Storage or sale of removed items on site will not be permitted.

Demolition: Contractor shall strip the site of all remaining materials not to remain as part of the finished work. All such materials shall be legally disposed of off-site at Contractor's expense except as otherwise noted on Plans. Items to be disposed of off-site include but are not limited to the following:

- A. Demolition and removal of concrete sidewalk, curb, gutter, apron, catch basin, metal grate, asphalt concrete and base rock;
- B. Removal of pavement markings;
- C. Salvaging and reinstallation of street signs and other items.

Where applicable, the pavement markings include lane lines, arrows, symbols, and numerals shall be removed by grinding or as approved by the Engineer. The Contractor shall use a grinder that minimizes damage to the existing asphalt but obliterates the marking. This work shall minimize the generation of dust. Should the Contractor damage the asphalt, they shall restore the surface to the satisfaction of the Engineer at no additional cost.

When the presence of asbestos, lead paint or hazardous substances are not shown on the plans or indicated in the specifications and the Contractor encounters materials which the Contractor reasonably believes to be asbestos or a hazardous substance as defined in Section 25914.1 of the Health and Safety Code, all such removal of asbestos or hazardous substances including any exploratory work to identify and determine the extent of such substances will be included in the lump sum price for this contract.

If the Contractor damages an existing improvement, which is to remain, he/she shall restore such improvement to as good a condition as existed before the damage or shall replace the improvement, when restoration is not acceptable, with an improvement of at least equal quality. Cost of such restorations or replacements shall be the Contractor's expense.

Where a portion of the existing surfacing is to be removed, the outline of the area to be removed shall be cut on a straight neat line with a power-driven saw to a minimum depth of 0.10 foot before removing the surfacing.

The Contractor shall remove, haul, and dispose all excess materials consistent with Section 11 "Disposal" of the Special Conditions.

The Contractor is responsible for having all underground utilities and covers identified by calling Underground Service Alert (USA) at 1-800-227-2600 prior to commencement of excavation. Where cold planing is performed, no additional compensation will be considered for cutter head teeth that may be damaged by any obstructions exposed or unexposed. It shall be the Contractor's responsibility to ascertain the location of all utilities, including maintenance holes and monuments.

Abandoned lines, meters and boxes, obstructions or piping shall be removed, plugged or capped in accordance with the requirements and approval of the agencies affected. It shall be the responsibility of the Contractor to ascertain whether any public facilities exist along the line of work, whether or not shown on the Plans; and Contractor shall, at the Contractor's expense, do any necessary work to save from damage all such property in or adjacent to the work, and shall repair all damage thereto caused by the Contractor's operations.

Prior to commencement of site grading work the Contractor shall notify the Engineer that the site has been cleared. Site grading shall not commence until the Engineer has completed review of the site and has given approval to proceed.

Remove Asphalt: Roadway base and surfacing shall be removed as required for the roadway in accordance with Section 19, "Earthwork," of the Standard Specifications and these Specifications, as shown on the Plans, and as directed by the Engineer. This bid item also includes removal of base rock as required for the improvements.

Where no joints exists between roadway surfacing to be removed and roadway surfacing to remain in place, the roadway surfacing shall be cut in a neat line to the full depth of the existing pavement with a power driven saw before the roadway surfacing is removed.

The Contractor, at his expense, shall repair materials to be salvaged that are damaged as a result of the Contractor's operations to the satisfaction of the Engineer.

Nothing in these Specifications shall relieve the Contractor from his responsibilities as provided in Section 7-1.09, "Public Safety," of the Standard Specifications.

Existing concrete sidewalk, roadways, curb and gutter to be removed shall be completely removed and disposed of in conformance with the provisions in Section 15-3, "Concrete Removal" and Section 14-10, "Solid Waste Disposal and Recycling", of the Standard Specifications and these Specifications, as shown on the Plans, and as directed by the Engineer. This bid item also includes removal of base rock as required for the improvements.

10-8.04 MEASUREMENT AND PAYMENT

The contract price paid per square foot for "Concrete and Asphalt Removal" (**Bid Item 7**) of the various types shall include full compensation for furnishing all labor, materials, tools, equipment, and incidentals and for doing all the work complete in place, including sawcutting, demolition and removal of asphalt and aggregate base, hauling, recycling, disposal, cleanup and other incidental work, as shown on the Plans, as specified in the Standard Specifications and these Specifications, and as directed by the Engineer.

SECTION 10-10 – EARTHWORK

10-10.01 GENERAL

Specifications for the excavation, filling, recompacting, grading and disposal of excess material. Earthwork shall conform to the applicable provisions of Section 19, "Earthwork", of the Standard Specifications and these Special Provisions and conform to the geotechnical report. Trenching and backfill shall conform to the Uniform Construction Standard drawings 330, 340, and 350.

Contractor shall refer to "Geotechnical Investigation, Second & Third Street Rehabilitation Project" prepare by Miller Pacific Engineering Group dated March 3, 2001 for soils conditions.

References:

- ASTM D1557 - Moisture-Density Relations of Soils and Soil-Aggregate Mixtures Using 10 lb rammer and 18 inch drop.
- ASTM D2216 - Laboratory Determination of Water (Moisture) Content of Soil, Rock, and Soil-Aggregate Mixtures
- ASTM D2419 – Sand Equivalent Value of Soils and Fine Aggregates
- ASTM D2487 - Classification of Soils for Engineering Purposes
- ASTM D2844 - Resistance R Value and Expansion Pressure of Compacted Soils
- ASTM D2922 - Density of Soil and Soil-Aggregate in place by Nuclear Methods (Shallow Depth)
- ASTM D3010 - Moisture Content of Soil and Soil-Aggregate in Place by Nuclear Methods (Shallow Depth)

10-10.02 SUBMITTALS

Contractor shall submit Sheeting and Shoring Plan for review and approval by the Engineer.

The Contractor shall furnish, without additional cost, such quantities of import materials as may be required for favorable review by the Engineer for test purposes. The Contractor shall cooperate with the Engineer and furnish necessary facilities for sampling and testing of all materials and workmanship. Submit test results for import materials. All material furnished and all work performed shall be subject to rigid inspection, and no material shall be delivered to the site until it has been favorably reviewed by the Engineer, or used in the construction work until it has been inspected in the field by the Engineer.

10-10.03 MATERIALS

1. Fill Materials
 - a. Aggregate Base – Class II aggregate base shall conform to the grading specified in Section 39-2.02B "Aggregate Gradations" of the Standard Specifications.
 - b. On-site soils may be suitable for use as compacted fill. Fill materials must meet the gradation requirements provided in the geotechnical report or as indicated in the plans.

Fill materials used to support the expanded intersection pavement area or other structural elements of the project should consist of non-expansive materials spread uniformly and continuously over the entire area. Structural fill shall be free of organic matter, have a Liquid Limit of less than 40, a Plasticity Index of less than 15, have a minimum R-value of 10, maximum particle size of 4-inches and have less than 50% silt and clay. New fills, if used under structures, should ideally be of uniform thickness to reduce potential differential settlements.

- c. Drain rock or Gravel - River run or crushed rock with a maximum dimension of $\frac{3}{4}$ inch, with no more than 10 percent passing the No. 200 sieve, and with a durability index of 40 or higher shall be used.
- d. Select Sand - This material shall be a clean material free of organic or other deleterious substances and of such gradation that a minimum of 90% will pass a No. 4 sieve and not more than 5% will pass a No. 200 sieve. If low chloride sand is required, the chloride content shall not exceed 30 parts per million by weight.
- e. Pea Gravel - This material shall be a clean material free of organic or other deleterious substances and shall consist of smooth rock with no facets or sharp edges. Stones shall have a maximum size of $\frac{3}{8}$ inch, and not more than 5% will pass a No. 16 sieve.
- f. Native Backfill - Where use of native soil is directed, prepare native soil as necessary to be free from clods or rocks larger than 3 inches in greatest dimension, and free from organic material and as approved by the Engineer.

10-10.04 EXECUTION

1. Construction

- a. Surplus Material - Unless otherwise specified, surplus excavated material shall be disposed in accordance with Section 11 "Disposal" of the Special Conditions.
- b. Hauling - When hauling is down over highways or city streets, loads shall be trimmed and the vehicle shelf areas shall be cleaned after each loading. Loads shall be watered after trimming to eliminate dust.
- c. Subgrade - Unless directed otherwise or indicated in the drawings, all on-site and imported fill and backfill should be uniformly conditioned to near the optimum moisture content. Properly moisture conditioned and cured materials should subsequently be placed in loose horizontal lifts of 8 inches thick or less, and uniformly compacted to a minimum of 90 percent relative compaction for general fill and 95 percent relative compaction to produce a firm, non-yielding surface when proof rolled with heavy construction equipment.

Subgrade shall be inspected for compliance to the soils report by the Owner/Geotechnical engineer prior to filling or on achieving final cut depth

- d. Finish Grading -
 - i. Finish surfaces shall be smooth, compacted and free from irregularities. The degree of finish shall be that normally obtainable with a blade-grader.
 - ii. Finish grades shall be as specified on the plans, except where a local change in elevation is required to match existing conditions, or to ensure proper drainage.
 - iii. When the work is at an intermediate stage of completion, lines and grades shall be as specified within 0.5 foot or as necessary to provide adequate drainage.

2. Field Quality Control

- a. Fill material shall be placed in horizontal layers and compacted with power operated tampers, rollers, idlers, or vibratory equipment.

3. Hard Rock Excavation - Where hard rock is encountered during excavation activities, the Contractor shall bring this condition to the attention of the Engineer at the time it is encountered and prior to proceeding with hard rock excavation. Contractor shall expect shallow, hard bedrock as indicated in the geotechnical report and visible in the field. No payment for extra effort for hard rock excavation, hauling, and disposal will be made.
4. Tests
 - a. Inspection Trenches – Engineer shall direct Contractor to construct inspection trenches in compacted or consolidated backfill to determine that Contractor has complied with these Specifications.
 - b. Hazardous substances are not shown on the plans or indicated in the specifications. If the Contractor encounters materials which the Contractor reasonably believes to be a hazardous substance, then he/she shall notify the Engineer as soon as possible and prior to further excavation. No payment for testing and hazardous material disposal will be made without first negotiating the terms for such payment and timely notification to the Engineer.

10-10.05 MEASUREMENT AND PAYMENT

Full compensation for all labor, materials, importing, exporting, testing, and equipment necessary to complete the work including hard rock excavation, hauling, and disposal as shown on the plans and specified herein shall be included in the contract prices for the various items of work and no additional compensation will be made therefor.

SECTION 10-11 – CONCRETE DRIVEWAY, GUTTER, AND RAMP

10-11.01 GENERAL

Concrete driveway approach shall conform to the Uniform Construction Standard, as modified in the Plans, these Specifications and as directed by the Engineer. Concrete curb ramps shall conform to the State Standard Curb Ramp Details Plan A88A and as modified in plan sheets C2.03 and C2.04 and as directed by the Engineer. All Work shall be done to the satisfaction of the Engineer.

Damage to the street, sidewalk, curbs and gutters from construction activities shall be repaired to the satisfaction of the City Engineer.

10-11.02 SUBMITTALS

The Contractor shall submit the concrete mix design and strength data to the Engineer for favorable review the following.

Supplier's certificates showing conformance with this specification shall be delivered to the Engineer with each shipment of materials delivered to the job site.

10-11.03 MATERIALS

- Portland Cement Concrete for fixed form concrete surface improvements shall be minor concrete conforming to the requirements of Section 90-2 "Minor Concrete" of the Standard Specifications with at least 505 pounds of cementitious material per cubic yard and 1-inch maximum graded coarse aggregate. No bagged mix is permitted. Hand mixing of Portland Cement Concrete for use in concrete surface improvements shall not be permitted. For concrete paving subjected to vehicular traffic, strength of concrete in place shall be 4,000 psi at 28 days. No admixtures shall be used without approval of the Engineer.

Maximum slump of fresh concrete permitted in these items shall be 4 inches. Slump shall be determined by either ASTM C-143 or California Test Method No. 520 at the Engineer's discretion.

- Aggregate base shall be Class 2, 3/4" maximum. When the aggregate base is constructed in more than one layer, the previously constructed layer shall be cleaned of loose and foreign matter by sweeping with power sweepers or power brooms, except that hand brooms may be used in areas where power cleaning is not practicable. Adequate drainage shall be provided during the entire period of construction to prevent water from collecting or standing on the area to be covered with aggregate base.
- Dowels, where noted or called for on the Plans or detail drawings, shall be smooth billet-steel bars conforming to the requirements of ASTM Designation A615 for Grade 40 bars.
- Polyvinyl Chloride Pipe (PVC): Pipe and Fittings: Polyvinyl chloride sewer/storm pipe: Less than 12 inches nominal size: ASTM D3034, SDR 14
- Truncated Domes shall be approved by the Engineer and meet requirements listed in the Part 2 of Title 24 of the California Code of Regulations Chapter 11B-705

10-11.04 EXECUTION

Formwork

- a. Forms for concrete surface improvements shall be subject to the approval of the Engineer. No concrete shall be placed prior to Contractor obtaining such approval.
- b. Forms for concrete surface improvements shall have a smooth and true upper edge and the side of the form to be placed next to concrete shall have a smooth finish. Forms shall be constructed rigid enough to withstand the pressure of the fresh concrete to be placed without any distortion.
- c. All forms shall have been thoroughly cleaned prior to placement and shall be coated with an approved form oil sufficient to prevent adherence of concrete prior to filling.
- d. Forms shall be carefully set to the alignment and grade required by the Plans. Forms shall be rigidly held in place by stakes set at intervals satisfactory to the Engineer. Sufficient clamps, spreaders and braces shall be installed to ensure the rigidity of the forms.
- e. Forms for driveways or gutter shall be equal to the full depth of the concrete as shown, noted or called for on the Plans or detail drawings. Composite forms made up from benders or thin planks of sufficient ply to ensure rigidity of the form in the shape required may be used on curves and curb returns.
- f. Gutter, driveways, and ramps shall have forms removed and be backfilled within 3 days after pouring.

Concrete Placement

- a. Where a portion of existing concrete surface improvements is to be reconstructed, the section to be removed shall first be separated from that to remain by means of a cut with an approved concrete saw to a minimum depth of one and one-half (1-1/2) inches at the first score line beyond the area to be replaced.
- b. All repairs to concrete surface improvements shall be made by completely removing and replacing the entire portion between the score lines or joints.
- c. Prior to subgrade work and concrete placement, all debris and trash will be removed from all areas related to this work. Existing subgrade surface shall be re-graded (if necessary) and re-compacted to conform to the grades shown on the Plans.
- d. Any concrete discolored, defaced, or otherwise damaged before official acceptance shall be cleaned, repaired or replaced at the Contractor's expense.
- e. If existing utilities are found to interfere with the permanent facilities being constructed under this Contract, immediately notify the Engineer and secure instructions. Do not proceed with permanent relocation of utilities until written instructions are received from the Civil Engineer.
- f. Contractor shall accurately grade and prepare the site to the lines and grades called for on the Plans and detail drawings with due provision for future surface improvements.
- g. Surface tolerance: Finished paving surfaces shall not vary more than 1/4 inch measured with a 10-foot metal straight edge, except at grade changes. No birdbaths or other surface irregularities will be permitted. Correct irregularities to the satisfaction of the Engineer without additional cost to the project.

- h. Concrete shall be transported in truck mixers or agitators and discharged with 70 minutes of leaving the plant.
- i. Gutters and driveways shall be given a median broom finish. The surface shall first be given a floated finish and final troweling shall be done with a steel trowel. The finished surface shall be free of all trowel marks and shall be uniform in texture and appearance. Broom texture shall be in the longitudinal direction.
- j. New concrete work shall match existing in finish, score pattern, and color, or as shown on the Plans, or as directed by the Engineer.
- k. Uniform Construction Standard (UCS) Dwg#100, 2 lbs. Davis Black #8084 (or equivalent) per Cu. Yd. of concrete shall be added to mix

Joints

- a. Expansion joints incorporating premolded joint fillers for fixed form concrete surface improvements shall be constructed at sixteen (16) foot intervals or as appropriate to match existing pattern and at the ends of curb returns. Expansion joint filler strip shall be an approved one piece premolded ½" thick strip conforming to the requirements of ASTM Designation D1051 or ASTM D 994. Place top of joint filler flush with finished concrete surface if joint sealant is not indicated. Expansion joint material shall be shaped to fit the cross section of the concrete prior to being placed.
- b. Single-Component, Self-Leveling, Silicone Joint Sealant for Concrete: Joint sealant shall conform to ASTM D 5893, Type SL. Install per manufacturer's guidelines.
- c. Scoring pattern and weakened plane joints (deep joints) shall be as indicated in the Plans and approved by the Engineer.
- d. Existing asphalt concrete shall be sawcut, removed and reconstructed for a minimum of 2-feet within edges of concrete work.
- e. Where new curb ramps elevations do not match the existing pavement surface, the Contractor shall provide temporary asphalt paving transition with a maximum 5% slope or as approved by the Engineer. The Contractor shall remove and dispose of the temporary asphalt transition for future pavement adjustments and/or overlays as indicated in the plans.
- f. Truncated dome panels shall be installed per manufacturer specifications in new curb ramps. Truncated dome panels shall be of vitrified polymer composite construction and embedded type. Color of truncated dome panel is yellow and shall be approved by the Engineer.

Testing

Slump tests shall be performed by the General Contractor in the presence of the Engineer at the beginning of each day's pour and at such additional times as required by the Engineer. Slump tests shall be made in accordance with current ASTM Designation C-143 or California Test Method No. 520 at the Engineer's discretion.

The Contractor shall hire an accredited materials testing laboratory to perform Quality Control tasks, including slump tests and compressive strength (per ASTM C39/C39M) tests. The Contractor shall sample and test one (1) cylinders at each curb ramp, or as directed by the Engineer.

Inspection

- a. The Engineer shall inspect and approve formwork and reinforcing steel placement prior to concrete pours. The General Contractor shall provide at least 24 hours' notice that inspections are required.

10-11.05 MEASUREMENT AND PAYMENT

The contract price paid per square foot for "Concrete Gutter" (**Bid Item 8**) shall include full compensation for furnishing all labor, materials, tools, equipment and incidentals and for doing all the work involved in placing concrete, complete in place, including, excavation, subgrade preparation, placement of Class II aggregate base, forming work, and finishing, as shown on the Plans, and specified herein, and as directed by the Engineer.

The contract price paid per square foot for "Concrete Curb & Gutter (UCS #105)" (**Bid Item 9 & Bid Item 9a**) shall include full compensation for furnishing all labor, materials, tools, equipment and incidentals and for doing all the work involved in placing concrete, complete in place, including, excavation, subgrade preparation, placement of Class II aggregate base, forming work, and finishing, as shown on the Plans, and specified herein, and as directed by the Engineer.

The contract price paid per each "Concrete Curb Ramp" (**Bid Item 10**) shall include full compensation for furnishing all labor, materials, tools, equipment and incidentals and for doing all the work involved in excavation, subgrade preparation, placement of Class II aggregate base, detectable warning surface, layout of curb ramp, forming work, placing concrete for curb, gutter, sidewalk/flatwork, finishing, replacing storm drain pipe, complete in place as shown in the Plans, and specified herein, and as approved by the Engineer.

SECTION 10-11 – ASPHALTIC CONCRETE GRINDING/MILLING

10-14.01 GENERAL

Specifications for providing asphaltic concrete grinding/milling as indicated in the plans. Related section includes Section 10-15 - Hot Mix Asphalt (Type A).

Protect concrete pavements and walks, curbs and bases, and other improvements adjacent to the operations with suitable materials. The Contractor shall be responsible for any damage caused by the Contractor's employees or equipment and shall make necessary repairs. Building and other surfaces shall be covered with paper or other protection, where required. All damage caused by the Contractor's operations shall be prepared or replaced as required. Damage to the existing curb and gutter resulting from operating the grinding machine or the "hand" clearing operations shall be corrected, to the satisfaction of the Engineer, by the Contractor at the Contractor's expense. The required grinding is to be performed without disturbing the existing curb and gutter which may be cracked and fragile. Any concrete gutters chipped by the pavement grinding operations shall be epoxy patched and "Mason's mix" shall not be permitted.

10-11.02 EXECUTION

Preparation

- a. Sawcutting shall be performed prior to the pavement grinding operations at intersections and conforms. The requirement to sawcut may be waived where a minimum one inch vertical face transverse to the conform point can be provided.
- b. The Contractor shall notify business owners forty-eight (48) hours in advance of grinding operations to cover parked vehicles or other personal items located in exposed areas.

Limits

- a. Limits of grinding are indicated in the Plans and shall be marked by the Engineer prior to grinding operations. The contractor shall be responsible to notify the Engineer for marking of limits a minimum of 48 hours prior to startup time.
- b. No additional compensation shall be made for Pavement Grinding in excess of the limits marked or as shown on the Plans unless so directed by the Engineer.

Operation: Pavement Grinding shall be in accordance with the applicable provisions of Section 42-3 of the Standard Specifications and shall involve:

- a. Full Width Grinding (to eliminate asphalt hump): Full Width Grinding shall provide a minimum grind depth as indicated in the Plans across the roadway between the gutter pans on each side of the asphalt hump.

In those areas where the existing asphalt pavement extends to the curb face over the P.C. gutter pan and is left after the grinding operation, the Contractor shall clear this residue asphalt pavement to the curb face. The area requiring "hand" clearing shall be that area between the edge of the grinding wedge left by operating the grinding machine to the curb face. The Contractor shall then use suitable methods to clear residue asphalt concrete from the gutter pan (grinding lip to curb face).

Pavement Grinding shall be accomplished by a grinding machine having a cutter head at least six feet wide and shall be operated so as not to produce excessive fumes or smoke.

At pavement grinding pavement conforms, immediately after performing the pavement grinding, the Contractor shall place temporary cutback asphalt to provide a smooth ramp for vehicular traffic. The cutback asphalt shall be maintained by the Contractor until overlay work has begun at which time all cutback asphalt shall be removed and disposed of.

Residue from grinding shall be removed from the roadbed by sweeping immediately after grinding.

The residue material ground from the roadway surface shall become the property of the Contractor who shall make arrangements for disposal outside the right-of-way.

10-11.03 MEASUREMENT AND PAYMENT

The contract price paid per square foot for "Asphaltic Concrete Grinding/Milling" (**Bid Item 6**) shall include full compensation for furnishing all labor, materials, tools, equipment and incidentals and for doing all the work involved in milling, including disposal, complete in place, as shown on the Plans, and specified herein, and as directed by the Engineer.

The quantities to be paid for shall be to the specified dimensions of grinding regardless of the number of passes required to conform to the depth requirement shown on the Plans.

SECTION 10-12 - HOT MIX ASPHALT (TYPE A)

10-12.01 GENERAL

Specifications are for providing asphaltic concrete paving as indicated on drawings. Contractor shall protect concrete pavements and walks, curbs and bases, and other improvements adjacent to the operations with suitable materials. The Contractor shall be responsible for any damage caused by the Contractor's employees or equipment and shall make necessary repairs. All damage caused by the Contractor's operations shall be prepared or replaced as required.

10-12.02 SUBMITTALS

Contractor shall submit Certificate of Compliance from manufacturer for approval prior to installation.

Contractor shall provide submittal for each Respective manufacturer's product data for manufactured products.

10-12.03 MATERIALS

- Hot Mix Asphalt shall be Type A using the Method process and shall conform to the provision in Section 39 "Hot Mix Asphalt" of the Standard Specifications and these Specifications. Hot Mix Asphalt shall be compacted to a relative compaction of not less than 95 percent.

Aggregate grading for the hot mix asphalt shall conform to the grading specified in Section 39-2.02B "Aggregate Gradations" of the Standard Specifications. The base and leveling courses shall be dense graded, 3/4-inch maximum aggregate size and the surface course shall be medium graded 1/2-inch maximum aggregate size. When material used in the surface course is to be hand raked, 3/8-inch maximum size shall be used.

The amount of asphalt binder to be mixed with the aggregate shall be between 4 percent and 6 percent by weight of the dry aggregate. The exact amount of asphalt binder to be mixed with the aggregate will be approved by the Engineer. The Contractor must submit mix design for approval to the Engineer.

Asphalt binder to be mixed with aggregate shall be a steam-refined asphalt conforming to the provisions in Section 92, "Asphalt Binders" and have a viscosity grade of PG 64-10. The pavement surface upon which hot mix asphalt is to be placed and all adjacent vertical surfaces of existing pavement, curbs, gutters, etc. shall be thoroughly cleaned prior to paving. The Contractor shall furnish and operate a self-loading motor sweeper with spray nozzles before and after paving operations where feasible. All other areas will require hand sweeping. The pavement shall be free of dust, dirt, water, and vegetation prior to paving.

- Asphaltic emulsion shall be applied to the surface of existing pavements preparatory to resurfacing with hot mix asphalt, and to all concrete surfaces which will be in contact with hot mix asphalt surfacing. Asphalt emulsion shall be SS-1H conforming to Section 37 of the Standard Specifications. The Contractor shall submit a copy of Certificate of Compliance for asphaltic emulsion
- GlasPave50 Paving Mat by Tensar or Engineer approved equivalent

10-12.04 EXECUTION

The surfaces upon which HMA is to be placed shall be thoroughly cleaned of all dirt, vegetation, and debris. Prior to application of tack coat, the parking lot shall be cleaned with a vacuum street sweeper and be clean of all dust

1. Placing Asphalt Concrete

- a. The asphalt paving machine shall be equipped with an electronic “sonic ski” system with a minimum of three (3) sensors to be positioned a minimum of 10-foot in front, 10-foot behind and adjacent to the drum of the paving machine. The system shall be designed to optimize a smooth and consistent road profile. All settings and inputs shall be programmed and adjusted to yield an average thickness equivalent to the paving thickness shown on the Plans. The engineer can cancel the use of the “sonic ski” system at any point without incurring any penalties by the contractor.
- b. Areas to be paved shall be covered with a layer of hot asphalt concrete surfacing not less than the thickness indicated after compaction. Where not indicated, compacted thickness shall three inches for roads, driveways, and aisles of parking areas.
- c. Paving asphaltic concrete shall be delivered, laid, rolled, and finished in accordance with Section 39 of the Caltrans Standard Specifications.
- d. Before placing asphalt concrete, a tack coat (paint binder) shall be applied to all vertical surfaces against which asphalt concrete surfacing will be placed. Asphaltic emulsion shall be applied to the surface of existing pavements at the approximate rate of one-sixteenth (1/16) gallon per square yard. Pools or unevenly distributed areas shall be redistributed by means of hand brooms. The emulsion shall be applied only so far in advance of the surfacing work that it has sufficient time to set, as required by the Engineer.
- e. After a tack coat of asphalt emulsion has been applied, hot mix asphalt shall be spread and compacted. It is contemplated that hot mix asphalt will be laid to a compacted thickness as specified. All loose material tracked out onto the new compacted surface shall be removed before an adjacent pass is made by the asphalt paver. All layers of hot mix asphalt shall be laid using an asphalt paving machine as specified in Section 39, Hot Mix Asphalt, of the Standard Specifications.
- f. The Contractor shall taper the new pavement thickness adjacent to the gutters in the streets designated by the Engineer. Tapering to the edge of the gutters shall be performed in such manner that adequate binding of the very fine asphalt material to the existing surface is obtained. Contractor shall, at the direction of the Engineer and pursuant to field conditions, apply additional binding material in these areas prior to the placement of the new hot mix asphalt, and shall adequately rake the coarse material so as to obtain the desired result. Crown heights may be adjusted at the direction of the Engineer. Aggregate segregation will be grounds for rejection.
- g. The location of all utility and City-owned structures that are covered over by the new pavement shall be legibly marked with paint on the new pavement and on the adjacent curb and/or sidewalk. In addition, the Contractor must make a list of each utility cover that is paved over and not raised to grade during the paving job (e.g. PG&E utility covers) and must notify the utility in writing of the location of said utility cover and the date that it was paved over. A copy of this

written notification must be sent to the City. If utility cover is paved over and not raised to grade during the paving job, the pavement must be at least 1-1/2 inches thick over the utility cover and no depression in the roadway surface can be left over the utility cover. If 1-1/2 inches of pavement cannot be laid over a recessed utility cover, then the hot mix asphalt shall be feathered to the grade of the utility cover and arrangements with the utility must be made to raise it to grade. Hot mix asphalt rolled gutters shall be resurfaced as directed by the Engineer as part of the overlay resurfacing work and no additional payment will be made therefor.

- h. Hot mix asphalt shall not be placed when the atmospheric temperature is below 50 degrees F (10 degrees C) or during unsuitable weather.
- i. Compaction of the asphalt shall be achieved using mechanical rollers. Rolling shall be performed in such a manner that cracking, shoving, or displacement will be avoided. Any displacement occurring as a result of reversing the direction of the roller or from any cause shall at once be corrected by the use of rakes and fresh asphalt mixture where required.
- j. Areas inaccessible to the rollers shall be compacted by use of a power compactor of the high impact vibration plate type capable of attaining the same compaction as the rolled areas. An adequate number of rollers shall be used with each paving operation.
- k. The completed surface shall be thoroughly compacted, smooth, and true to grade and cross section, free from ruts, humps, depression, irregularities, or segregated material.
- l. Finish paving shall conform to finish elevations within plus or minus 0.01 of a foot and shall be level to within plus or minus 1/4 inch in 10 feet when measured with a 10 foot straightedge in any direction. Finish surface of the wearing course shall be thoroughly compacted, smooth, and free from ruts, humps, depressions, cold joints, or other irregularities.
- m. Public traffic shall be permitted the use of the street area providing that such traffic does not interfere with the continuity of the paving operations. When street operations are suspended, all equipment shall be removed from portions of the streets that are to be used by the public traffic. Where work is unfinished at a pedestrian crosswalk at the end of a working day, the edge of the paved surface to said crosswalk shall be feathered to provide a smooth pathway for foot traffic. The pavement shall be protected from traffic until thoroughly cooled and set. Hot mix asphalt rolled gutters shall be compacted as directed by the Engineer as part of the overlay resurfacing work and no additional payment will be made therefor.
- n. Any rollers shall be equipped with pads and water systems that prevent sticking of asphalt mixtures to the steel-tired wheels. A parting agent, which will not damage the asphalt mixture, as determined by the Engineer, may be used to aid in preventing the sticking of the mixture to the wheels.
- o. The finished surface shall be cat-tracked within 24 hours of completion of paving work. Final striping shall be applied within one week of completion of paving work.
- p. Pavement fabric shall be installed per Manufacturer's recommendation.

2. Field Quality Control

- a. The Contractor shall control the quality of the work and shall provide adequate testing to assure compliance with these Specifications.
- b. After completion of paving work, all paving shall be inspected. Any resulting "ponds" shall be ringed with chalk. Such hollows shall be corrected with addition of asphalt paving materials and rerolling until all paving is completely level and free from hollows and high spots.
- c. As part of its quality control program, Contractor shall employ a competent qualified testing subcontractor to perform in-place density and compaction tests of the completed pavement in accordance with California Test 375 to determine compliance with specified requirements. A minimum of: three (3) tests shall be performed at each roadway location and/or as directed by the Engineer to verify compliance. Contractor shall provide all test results to the Engineer by the end of the next business day.

The HMA shall be placed in 3-inch maximum lifts. Conform sections shall be squared off and hand raked to a neat straight line. Edges at curb shall be hand raked and rolled with a small roller or tamper when larger roller cannot be used.

Finished pavement shall be free from ripping, ruts, humps, depressions, improper conforms, and other irregularities per the State Standard Specifications. Unacceptable paving shall be removed by cold planing and repaved 1-inch deep.

10-12.05 MEASUREMENT AND PAYMENT

The work of "Hot Mix Asphalt (Type A)" (**Bid Item 11**) will be measured by the tons of asphalt installed. The Contractor will not be paid for asphalt thickness above that which is specified. Contractor shall submit asphalt tags upon arrival of the delivery truck, or as directed by the Engineer.

The contract price paid per square yard for "Pavement Fabric", (**Bid Item 12**) shall include full compensation for furnishing all labor, materials, tools, equipment, and incidentals, and for doing all the work involved in furnishing and placing pavement fabric complete in place as shown on the Plans, as specified in the Standard Specifications and these Specifications, and as directed by the Engineer.

SECTION 10-13 – AGGREGATE BASE

10-13.01 GENERAL

Specifications for furnishing, spreading, and compacting aggregate base course for pavements as indicated.

Damage to the street, sidewalk, curbs and gutters from construction activities shall be repaired to the satisfaction of the City Engineer.

10-13.02 SUBMITTALS

Contractor shall provide submittal for the Respective manufacturer's product data for manufactured products.

10-13.03 MATERIALS

Aggregate base shall be Class 2, 3/4" maximum. When the aggregate base is constructed in more than one layer, the previously constructed layer shall be cleaned of loose and foreign matter by sweeping with power sweepers or power brooms, except that hand brooms may be used in areas where power cleaning is not practicable. Adequate drainage shall be provided during the entire period of construction to prevent water from collecting or standing on the area to be covered with aggregate base.

10-13.04 EXECUTION

1. Examination
 - a. Call for an inspection by the Engineer and obtain written acceptance of the prepared subgrade or subbase before proceeding with the placement of aggregate base course.
 - b. The subgrade or subbase to receive aggregate base course, immediately prior to spreading, shall conform to the compaction and elevation tolerances indicated for the material involved and shall be free of standing water and loose or extraneous material.
2. Installation Standards
 - a. Aggregate base course shall be applied over the prepared subgrade or subbase and compacted in accordance with Section 26 of the Caltrans Standard Specifications or as approved by the Geotechnical Engineer.
 - b. Aggregate base course shall be minimum uniform thickness after compaction of dimensions indicated. Where not indicated, compacted thickness shall be six inches for driveways/sidewalks and eight inches for roadways.
 - c. All compaction expressed in percentages in this section refers to the maximum dry density as determined by California Test Method No. 216.
3. Spreading of Material
 - a. Aggregate for base course shall be delivered as uniform mixture of fine and coarse aggregate and shall be spread in layers without segregation.
 - b. Aggregate base course material shall be free from pockets of large and fine material. Segregated materials shall be remixed until uniform.

- c. Aggregate base material shall be moisture-conditioned to near optimum moisture content in accordance with the applicable requirements of Section 10 of the Caltrans Standard Specifications.
 - d. Aggregate base course six inches and less in thickness may be spread and compacted in one layer. For thicknesses greater than six inches, the base course aggregate shall be spread and compacted in two or more layers of uniform thickness not greater than six inches each.
4. Compacting
- a. Relative compaction of each layer of compacted aggregate base material shall be not less than 95 percent based on maximum dry density as determined by California Test Method No. 216 or as noted in the design plan.
 - b. Thickness of finished base course shall not vary more than 3/4 inch from the indicated thickness at any point. Base which does not conform to this requirement shall be reshaped or reworked, watered, and recompact to achieve compliance with specified requirements.
 - c. The surface of the finished aggregate base course at any point shall not vary more than 3/4 inch above or below the indicated grade.
5. Field Quality Control
- a. Perform field tests in accordance with ASTM D2922 or ASTM D1557 as directed by the Geotechnical Engineer to determine compliance with specified requirements for density and compaction of aggregate base material, and with ASTM D3010 to determine moisture-content compliance of the installed base course.

10-13.05 MEASUREMENT AND PAYMENT

Full compensation for providing "Aggregate Base" shall include furnishing all labor, materials, tools, equipment, and incidentals, and for doing all the work involved in furnishing and placing aggregate base and compaction tests complete in place as shown on the Plans, as specified in the Standard Specifications and these Specifications, and as directed by the Engineer shall be considered as included in the contract prices for the various items of work and no additional compensation will be made therefor.

SECTION 10-14– PAVEMENT REPAIR

10-14.01 GENERAL

Specifications are for providing asphaltic concrete paving dig-outs as directed by the Engineer. Contractor shall protect asphalt and/or concrete pavements and walks, curbs and bases, and other improvements adjacent to the operations with suitable materials. The Contractor shall be responsible for any damage caused by the Contractor's employees or equipment and shall make necessary repairs. All damage caused by the Contractor's operations shall be prepared or replaced as required.

10-14.02 SUBMITTALS

Contractor shall provide submittal for each Respective manufacturer's product data for manufactured products.

10-14.03 MATERIALS

- See Section 10-12 Hot Mix Asphalt (Type A)

10-14.04 EXECUTION

As indicated in the field by the Engineer in white paint, the Contractor shall coordinate quantities for standard and deep dig-out repairs. Contractor shall grind all limits of dig-outs and field determine with the Engineer the appropriate depth of dig-out. Contractor shall assume 4" minimum to 10" maximum grind depths for deep dig-outs. Contractor shall be responsible for removal, hauling, and disposal of excess materials.

- See Section 10-12 Hot Mix Asphalt (Type A)

10-14.05 MEASUREMENT AND PAYMENT

The contract price paid per square foot for "HMA Shallow Digout" (**Bid Item 13**) shall include full compensation for furnishing all labor, materials, tools, equipment and incidentals and for doing all the work involved in repairing damage asphalt, complete in place, including, grinding, asphalt removal and disposal, and asphalt placement, as shown on the Plans, and specified herein, and as directed by the Engineer.

The contract price paid per square foot for "HMA Deep Digout" (**Bid Item 14**) shall include full compensation for furnishing all labor, materials, tools, equipment and incidentals and for doing all the work involved in repairing damage asphalt, complete in place, including, grinding, asphalt removal and disposal, subgrade preparation, and asphalt placement, as shown on the Plans, and specified herein, and as directed by the Engineer.

SECTION 10-15 – PAVEMENT STRIPING AND MARKINGS

10-15.01 GENERAL

Specifications for providing traffic striping and control markings on pavement as indicated.

10-15.02 SUBMITTALS

Contractor shall submit shop drawings and diagrams, indicating stripe width of roadway divider stripes, style and size of letters for pavement marking designation, configuration and dimensions of arrows and any other traffic control markings on pavement.

Contractor shall submit evidence or affidavit which certifies that paint to be used complies with latest CARB/VOC regulations.

A certificate of compliance shall be provided by the Contractor to the City that all materials used for pavement marking and legends conform to the Specifications.

10-15.03 MATERIALS

- Traffic stripes and pavement markings shall be installed per Section 84 of the Standard Specifications and these Specifications.
- All striping and pavement markings shall be Thermoplastic and conform to either State Specifications 8020-41G-19 or 8010-41G-21. State Specifications for thermoplastic material and glass beads may be obtained from the Transportation Laboratory, P.O. Box 19128, Sacramento, California, 95819- (916) 739-2400. Thermoplastic material for all pavement markings shall be applied at a minimum thickness of 0.070-inch.

10-15.04 EXECUTION

1. All existing pavement markers and thermoplastic stripes and legends within the roadway reconstruction shall be completely removed immediately prior to hot mix asphalt paving. Markers, stripes, or legends which are removed shall be replaced with temporary markers, stripes and legends prior to opening the roadway to vehicular or pedestrian traffic.
2. All traffic striping, pavement markings (legend), and pavement markers removed prior to excavation or grinding shall be replaced except as modified in the Plans or as directed by the Engineer. Prior to replacement, the Contractor shall layout all striping patterns and marking locations by cat tracking or other suitable means for review and approval by the Engineer. Any striping and/or markings installed by the Contractor that the Engineer has not pre-approved, and that the Engineer determines are installed improperly or in the wrong location, shall be removed and replaced to the satisfaction of the Engineer at the Contractor's sole expense.
3. Surfaces which are to receive markings shall be thoroughly cleaned, free from loose materials and dry. Such areas shall be prepared by the Contractor to the satisfaction of the Engineer.
4. Any damage to existing or newly placed traffic striping due to the failure of the Contractor to protect the work, and correction of errors, shall be repaired by the Contractor at no additional cost.
5. All new traffic stripes and pavement markings shall meet the following requirements for applications with enhanced wet night visibility:

Quality Control and Assurance

1. Within 14 days of applying a thermoplastic traffic stripe or pavement marking with enhanced wet night visibility, the retroreflectivity must be a minimum of 700 millicandelas per square meter per lux for white stripes and markings and 500 millicandelas per square meter per lux for yellow stripes and markings. Test the retroreflectivity under ASTM E 1010. Have a reflectometer as described in ASTM E 1010 at the job site for making these measurements.
2. Thermoplastic traffic stripes and pavement markings with enhanced wet night visibility must consist of a single uniform layer of thermoplastic and 2 layers of glass beads as follows:
 - a. The first layer of glass beads must be on the Authorized Material List under high-performance retroreflective glass beads for use in thermoplastic traffic stripes and pavement markings. The color of the glass beads must match the color of the stripe or marking to which they are being applied.
 - b. The 2nd layer of glass beads must comply with AASHTO M 247, Type 2.
3. Both types of glass beads must be surface treated for use with thermoplastic under the bead manufacturer's instructions.

Construction

1. Use a ribbon extrusion or screed type applicator to apply a thermoplastic traffic stripe.
2. Operate the striping machine at a speed of 8 mph or slower during the application of thermoplastic traffic stripe and glass beads.
3. Apply a thermoplastic traffic stripe at a rate of at least 0.38 pounds per foot of 4-inch wide solid stripe. The applied thermoplastic traffic stripe must be at least 0.090 inch thick.
4. Apply a thermoplastic pavement marking at a rate of at least 1.06 pounds per square foot. The applied thermoplastic pavement marking must be at least 0.100 inch thick.
5. Apply a thermoplastic traffic stripe and both types of glass beads in a single pass. Apply the thermoplastic 1st, followed immediately by consecutive applications of high-performance glass beads and then AASHTO M 247, Type 2 glass beads. Use 2 separate applicator guns for the glass beads, 1 applicator gun for each type of glass bead.
6. Contractor may apply glass beads by hand methods on pavement markings.
7. Distribute all glass beads uniformly on traffic stripes and pavement markings. Apply high-performance glass beads at a rate of at least 6 pounds per 100 square feet of stripe or marking. Apply AASHTO M 247, Type 2 glass beads at a rate of at least 8 pounds per 100 square feet of stripe or marking. The combined weight of the 2 types of glass beads must be greater than 14 pounds per 100 square feet of stripe or marking.

10-15.05 MEASUREMENT AND PAYMENT

The contract lump sum price for "Pavement Markings" (**Bid Item 21**) shall include full compensation for furnishing all labor, materials, tools, equipment, and incidentals, and for doing

all the work involved in preparing the surface (including striping and marker removal) and installation of pavement striping as shown in the Plans, as specified in the Standard Specifications and these Specifications, and as directed by the Engineer.

SECTION 10-16 – CURB PAINT

10-17.01 GENERAL

Specifications for providing curb paint as indicated.

10-17.02 SUBMITTALS

Contractor shall submit shop drawings and diagrams, indicating location, color, and dimensions of curb paint.

10-17.03 MATERIALS

- Curb paint shall conform to the requirements in ASTM Designation: D 6628-01.
- Retroreflectivity of the paint traffic stripes and pavement markings shall conform to the requirements in ASTM Designation: E 1010.
- Paint type shall be Waterborne Traffic Line conforming to the requirements of Federal Specification TT-P-1952E.

Painted curb markings work consists of painting curbs with (red, white, or blue) paints as shown in the Plans. All work shall be performed in conformance with the provisions in Section 84, "Traffic Stripes and Pavement Markings," of the Standard Specifications and these Specifications at the locations shown on the Plans and as directed by the Engineer.

10-17.04 EXECUTION

1. Application shall consist of two separate coats of traffic paint of the appropriate color to the face and top of the curb.
2. Nothing in these Specifications shall relieve the Contractor from their responsibilities as provided in Section 7-1.09, "Public Safety," of the Standard Specifications.

10-17.05 MEASUREMENT AND PAYMENT

The contract lump sum price paid for "Curb Paint" (**Bid Item 22**) shall include full compensation for furnishing all labor, materials, tools, equipment, and incidentals, and for doing all the work involved in painting red curbs as shown in the Plans, as specified in the Standard Specifications and these Specifications, and as directed by the Engineer.

SECTION 17-17 – UTILITY ADJUSTMENT TO GRADE (REVOCABLE ITEM)

17-17.01 GENERAL

Valve boxes, manholes, and other similar facilities shall be adjusted to grade after curb ramp, driveway, and/or pavement improvements, where applicable, in accordance with the applicable provisions of Section 15-1.03 of the Standard Specifications. Contractor shall adhere to applicable utility agency requirements for raising utility. Adjustment of PG&E facilities shall be per Greenbook requirements.

17-17.02 SUBMITTALS & MATERIALS

The Contractor shall submit material cut sheets and suppliers' certificates for the following materials, including but not necessarily limited to: grade rings, Portland Cement concrete, and mortar.

17-17.03 EXECUTION

Use of metal riser rings for storm drain maintenance holes is not acceptable. Grade rings, if used, shall be placed before resurfacing. The height of the grade ring shall be equal to the thickness of the overlay pavement to be placed, or shall be of such height so as to adjust the maintenance hole to grade.

Where frames and covers cannot be lowered flush after cold planing or before replacing asphalt surfacing, frames and covers shall be protected utilizing the following alternatives:

- Ramp section (cut-back) around "iron" and paint white
- Place lighted Portable Barricade over iron

Existing water valve access covers and fire hydrants shall be adjusted to grade in accordance with the Marin Municipal Water District (MMWD) Standards and these Specifications.

Where frames and covers cannot be lowered flush after cold planing or before replacing asphalt surfacing, frames and covers shall be protected utilizing the following alternatives:

- Ramp section (cut-back) around "iron" and paint white
- Place lighted Portable Barricade over iron

All utility covers encountered in the area to be overlaid with Hot Mix Asphalt shall be carefully referenced out using spray chalk or similar non-permanent marking media prior to the overlay by the Contractor. Using the reference markings, the locations of the covers shall be painted on the pavement surface immediately after paving to assure they can be found in an emergency.

Covers shall be adjusted so that there will not be any perceptible difference in elevation between the finished pavement surface and the cover. The Engineer shall be the sole judge of the acceptable degree of smoothness of passage of a motor vehicle over the adjusted covers.

Portland cement concrete used for adjusting covers shall be minor concrete conforming to the requirements of Section 90-2 "Minor Concrete" of the Standard Specifications with at least 505 pounds of cementations material per cubic yard and 1-inch maximum graded coarse aggregate. No bagged mix is permitted.

Mortar used in resetting maintenance hole covers shall conform to the provisions in Section 51-1.02F, "Mortar" of the Standard Specifications.

Salvaged materials which are undamaged may be reinstalled as directed by the Engineer.

Structures built of cast-in-place or precast concrete and brick or vitrified clay pipe parts shall be replaced in kind, unless otherwise permitted by the owners of the facilities.

Each of the respective utility company shall retain the ability to decrease the amount of a contract item of work or eliminate in its entirety. No adjustment to the number of working days will be made.

Contractor shall provide at least 48 hours advance notice to each respective utility agency of iron castings to be adjusted to grade.

17-17.04 MEASUREMENT AND PAYMENT

Water (MMWD), gas (PG&E), electrical (PG&E), and telecommunication (ATT&T and Comcast) measurement and payment items are revocable items. Bid items noted as "revocable items" may be deleted entirely or in part from the Work at the option of the City. The provisions of Section 9-1.06B, "Increases of More Than 25 Percent", and Section 9-1.06C, "Decreases of More Than 25 Percent", of the Standard Specifications shall not apply to such omission, and no compensation will be allowed the Contractor by reason of such omission.

The unit price paid for each "Utility Adjustment - Water Valve (Revocable Item)" (**Bid Item 15**) shall include full compensation for furnishing all labor, materials, coordination with utility agency, and equipment necessary to complete the work as shown on the Plans and specified herein and as directed by the Engineer and no additional payment will be allowed therefor.

The unit price paid for each "Utility Adjustment - Sewer Rodding Inlet" (**Bid Item 16**) shall include full compensation for furnishing all labor, materials, coordination with the utility agency, and equipment necessary to complete the work as shown on the Plans and specified herein and as directed by the Engineer and no additional payment will be allowed therefor.

The unit price paid for each "Adjust Sanitary Sewer Manhole to Grade" (**Bid Item 17**) shall include full compensation for furnishing all labor, materials, coordination with the utility agency, and equipment necessary to complete the work as shown on the Plans and specified herein and as directed by the Engineer and no additional payment will be allowed therefor.

The unit price paid for each "Adjust Electrical Box to Grade (Revocable)" (**Bid Item 18**) shall include full compensation for furnishing all labor, materials, coordination with the utility agency, and equipment necessary to complete the work as shown on the Plans and specified herein and as directed by the Engineer and no additional payment will be allowed therefor.

The unit price paid for each "Adjust Telecom Manhole Cover to Grade (Revocable)" (**Bid Item 19**) shall include full compensation for furnishing all labor, materials, coordination with the City, and equipment necessary to complete the work as shown on the Plans and specified herein and as directed by the Engineer and no additional payment will be allowed therefor.

The unit price paid for each "Adjust Traffic Box to Grade" (**Bid Item 20**) shall include full compensation for furnishing all labor, materials, coordination with the City, and equipment necessary to complete the work as shown on the Plans and specified herein and as directed by the Engineer and no additional payment will be allowed therefor.

SECTION 10-18 – ROADSIDE SIGNS

10-18.01 GENERAL

Reset roadside signs shall be salvaged and installed on new foundations at the locations shown on the Plans or where designated by the Engineer and in conformance with the provisions in the Standard Plans and Specifications and these special provisions.

10-18.02 SUBMITTAL

Contractor shall provide submittal for each Respective manufacturer's product data for manufactured products.

10-18.03 MATERIALS

- Salvaged Sign(s) shall be installed per Section 56 of the Standard Specifications and these Specifications.
- Roadside sign posts shall be one of the following or approved equal:

1. Western Highway Products

10680 Fern Ave.
Stanton, CA 90680
(800)479-3793
Model: Ulti-Mate Sign Support System

2. Zumar Industries, Inc.

9719 Santa Fe Springs Road
Santa Fe Springs, CA 90670
(800)654-7446 www.zumar.com
Model: Perforated Square Steel Sign Posts

3. Tapco

5100 W. Brown Deer Road
Brown Deer, WI 53223
(800)236-0112 www.tapco.com
Model: Galvanized Square Post

- Posts for roadside signs shall conform to State Standard Plan RS1. Posts shall have a bolt installed at the base of the post, as recommended by the manufacturer, and as directed by the Engineer. Posts shall be 12-gage galvanized steel 1.75-inch square tube with perforations, weighing 2.09 pounds per linear foot.

10-18.04 EXECUTION

1. Existing roadside signs shall be removed and salvaged as shown on the Plans. Foundations and posts shall be removed and legally disposed of outside of the Right-of-Way. Metal sign posts to be removed in sidewalk areas shall be removed by cutting and grinding the posts flush with the grade of the sidewalk. Any holes or depressions shall be leveled with grout; vertical ledges or protrusions greater than 1/4" shall not be allowed.
2. Existing roadside signs shall not be removed until replacement signs have been installed

or until the existing signs are no longer required for the direction of public traffic, unless otherwise directed by the Engineer.

3. Roadside signs and mounting shall be installed at the locations shown on the Plans, or where directed by the Engineer and shall conform to the provisions in Section 56-4, "Roadside Signs," of the State Standard Specifications and these Special Provisions. Existing and new signs to be mounted to existing or new posts shall be done in accordance with applicable Caltrans standards.

10-18.05 MEASUREMENT AND PAYMENT

The contract unit price paid to "Reset Roadside Sign" (**Bid Item 23**) shall be paid per each and shall include full compensation for furnishing the sign and sign post, all labor, materials, tools, equipment, incidentals, installation of posts and foundations, and for doing all the work involved in installing roadway signs as shown in the Plans.

SECTION 10-19 – CRACK SEAL

10-19.01 GENERAL

Cracks in existing asphalt concrete surfacing of traffic lanes and shoulders shall be prepared and filled with crack sealant and covered with sand as shown on the plans and in conformance with these special provisions.

10-19.02 SUBMITTAL

The Contractor shall provide the Engineer with a Certificate of Compliance conforming to the provisions in Section 6-2.03C, "Certificate of Compliance," of the Standard Specifications for each shipment of crack sealant. The certificate shall certify that the sealant conforms to the specifications, and shall be accompanied with storage and heating instructions and cautions for the material.

10-19.03 MATERIALS

- Rubberized Asphalt Crack Seal per Section 37-6. This work shall consist of cleaning all cracks wider than 1/4 inch in the asphalt concrete pavement, and filling cracks less than 1/2 inch wide with rubber asphalt joint seal as specified in these special provisions, and as directed by the Engineer.

Test	ASTM Designation	Requirements
Softening Point	D 36	180° F. min.
Cone Penetration @ 77°F.	D 3407	30 dmm min.
Resilience @ 77°F.	D 3407	40% min.
Flow	D 3407	3 mm max.

10-19.04 EXECUTION

Cracks seal shall be performed on cracks of a width between approximately ¼ inch to ½ inch wide. Wider cracks shall be filled with a suitable filling material as approved by the Engineer. Limits of lanes and shoulders to be prepared and sealed shall be as directed by the Engineer.

Immediately prior to applying the sealant, the joints shall be cleaned by blast cleaning or hand methods and then cleaning with high pressure air jets to remove all residue and foreign material. Water jets will not be allowed. Crack surfaces shall be surface dry at the time the sealant is applied.

Crack seal materials shall be used in conformance with the manufacturer's recommendations. Joint seal materials shall not be placed when the surface temperature is below 50 degrees F.

The finished crack seal shall be bonded to the faces of the joint groove such that there is no separation or opening between the sealant and the faces of the crack groove, and there shall be no cracks, separation or other opening in the sealant.

When cured, crack sealant shall be at least flush with the pavement surface or extend no more than one quarter (1/4) inch above the pavement surface.

All properly sealed cracks shall be covered with clean sand to prevent tracking of crack sealant by vehicles or pedestrians.

The Contractor shall remove crack seal material improperly placed, clean cracks as specified herein and then reseal the cracks at his expense.

The asphalt crack sealant shall be a mixture of paving asphalt and ground rubber or ground rubber and polymer.

The graduation of the ground rubber shall be such that 100 percent will pass a No. 8 sieve.

The asphalt crack sealant shall conform to the following requirements:

The asphalt crack sealant material shall be furnished premixed in containers with an inside liner of polyethylene. Package material shall not exceed 60 pounds in weight.

The asphalt crack sealant material shall be capable of being melted and applied to cracks and joints at temperatures below 400°F. When heated, it shall readily penetrate cracks 0.25-inch wide or wider.

B. Asphalt Concrete Potholing. Asphalt concrete shall be Type "A" and shall conform to the provisions in Section 39 of the State Standard Specifications and these special provisions.

Asphalt Concrete Potholing shall be constructed using Type "A", 3/8 inch maximum (medium) graded aggregate when the thickness is 0.05' or less. Asphalt Concrete Potholing shall be constructed using Type "A", 1/2 inch maximum (medium) graded aggregate when the thickness is greater than 0.05'. AR-4000 grade asphalt shall be used.

Asphalt Concrete Potholing shall consist of placing asphalt concrete by hand and compacting by suitable means.

Asphalt Concrete Potholing shall be placed in all cracks wider than 1 inch after cleaning, course surfaces, pavement separations and irregular depressions. Large areas shall be marked by the engineer following the placement of rubberized asphalt crack sealant. Asphalt concrete potholing shall be constructed after keycutting and before placing the pavement reinforcing fabric.

Asphalt concrete potholing shall be placed between the score line and the lip of new curb and gutter to the depth of the new gutter on existing streets to be resurfaced and at other locations as indicated on the project plans.

A tack coat of RS-1 or SS-1 shall be applied to the existing pavement surface and edges before placing asphalt concrete potholing.

Cracks shall be squeegeed as necessary after application of the crack sealant material.

Within 2 days after application of sealant, sealed cracks that reopen or in which the sealant material sags below the surrounding asphalt concrete surfacing and shoulders shall be resealed.

Light brooming shall be performed to remove loose excessive sand prior to opening a lane to public traffic that is not controlled by a pilot car.

10-13.05 MEASUREMENT AND PAYMENT

Full compensation for providing "Crack Sealing" shall include furnishing all labor, materials, tools, equipment, and incidentals, and for doing all the work involved in furnishing and placing aggregate base and compaction tests complete in place as shown on the Plans, as specified in the Standard Specifications and these Specifications, and as directed by the Engineer shall be considered as included in the contract prices for the various items of work and no additional compensation will be made therefor.

Appendices

Appendix A – Uniform Construction Standard (UCS) Details, May 2018
Caltrans Standard Plans (2018)

Appendix B – Draft Encroachment Permit

1. EXISTING CONCRETE SHALL BE REMOVED AT EXPANSION OR WEAKENED PLANE JOINTS OR AT SAWCUTS AS FIELD MARKED BY AGENCY ENGINEER. SAWCUTS MUST GO ENTIRELY THROUGH CONCRETE.
2. FOR NEW DEVELOPMENT, NO UTILITY BOXES OR POLES WILL BE PERMITTED IN THE SIDEWALK AREA WITHOUT THE PRIOR WRITTEN APPROVAL OF THE AGENCY ENGINEER.
3. WHERE UNDERCUT SUBGRADE OR UNSUITABLE SUBGRADE MATERIAL IS ENCOUNTERED, THE AGENCY ENGINEER MAY REQUIRE REMEDIAL WORK TO BE DONE, INCLUDING OVER EXCAVATION AND BACKFILLING WITH CRUSHED ROCK AND, WHEN DIRECTED BY THE ENGINEER, PLACING GEOTEXTILE FABRIC BENEATH THE NEW CONCRETE SECTION.
4. SUBGRADE SHALL BE COMPACTED TO AT LEAST 95% RELATIVE COMPACTION IN THE TOP SIX INCHES.
5. NEW WORK SHALL MATCH EXISTING AS CLOSELY AS POSSIBLE IN FINISH, SCORING AND COLOR. FOR NEW INSTALLATIONS PLACED ADJACENT TO EXISTING, 2LB. DAVIS BLACK #8084 (OR EQUIVALENT) PER CU. YD. CONCRETE SHALL BE ADDED TO MIX.
6. EXCEPT WHERE SPECIFIED OTHERWISE HEREIN, NO ADMIXTURES SHALL BE USED WITHOUT THE PERMISSION OF THE AGENCY ENGINEER.
7. FORMS SHALL MEET GRADE AND FORM FACES SHALL NOT VARY FROM THE DIMENSIONS SHOWN BY MORE THAN 1/2 INCH.
8. NO CONCRETE SHALL BE PLACED UNTIL THE AGENCY ENGINEER HAS INSPECTED AND APPROVED FORMS AND SUBGRADE/BASE.
9. SUBGRADE/BASE SHALL BE THOROUGHLY WETTED IMMEDIATELY PRIOR TO PLACING CONCRETE.
10. CONCRETE SHALL BE A MINIMUM CLASS B (5 SACK MIX) WITH 1 INCH MAXIMUM AGGREGATE FROM AN APPROVED MIXING PLANT. NO BAGGED MIX IS PERMITTED.
11. CONCRETE SHALL HAVE A SLUMP OF NOT MORE THAN FOUR INCHES.
12. FOR SIDEWALKS AND DRIVEWAY APPROACHES, 1/4 INCH DEEP SCORE LINES SHALL BE PLACED AT FOUR FEET ON CENTER OR AS DIRECTED BY THE AGENCY ENGINEER.
13. WEAKENED PLANE JOINTS AT LEAST 3/4" DEEP SHALL BE PLACED AT A MINIMUM 16 FEET ON CENTER EXCEPT FOR SIDEWALKS AND DRIVEWAY APPROACHES WHICH SHALL BE A MINIMUM 5 FEET ON CENTER.
14. 3/8 INCH THICK EXPANSION JOINTS SHALL BE PLACED ON BOTH SIDES OF DRIVEWAY APPROACHES, AT CURB AND SIDEWALK RETURN POINTS, DRAINAGE STRUCTURES AND OTHER LOCATIONS AS SHOWN ON THE PLANS.
15. ALL EXPOSED EDGES SHALL BE ROUNDED WITH 1/2 INCH RADIUS TOOL.
16. ALL FLAT SURFACES SHALL BE LIGHT BROOM FINISHED UNLESS OTHERWISE SPECIFIED BY AGENCY ENGINEER.
17. CURBS, SIDEWALKS AND DRIVEWAY APPROACHES SHALL HAVE FORMS REMOVED AND BE BACKFILLED WITHIN SEVEN DAYS AFTER POURING.
18. THE DESIGNATED DIMENSIONS AND SLOPES MAYBE MODIFIED TO ACCOMMODATE EXISTING ADJACENT FACILITIES SUBJECT TO THE APPROVAL OF THE AGENCY ENGINEER.

UNIFORM STANDARDS ALL CITIES AND COUNTY OF MARIN	REQUIREMENTS FOR CONCRETE CURB, GUTTER, SIDEWALK, DRIVEWAY AND OTHER "FLATWORK"						MAY 2008
							DWG. NO.
							100
	REV.	DATE	BY				

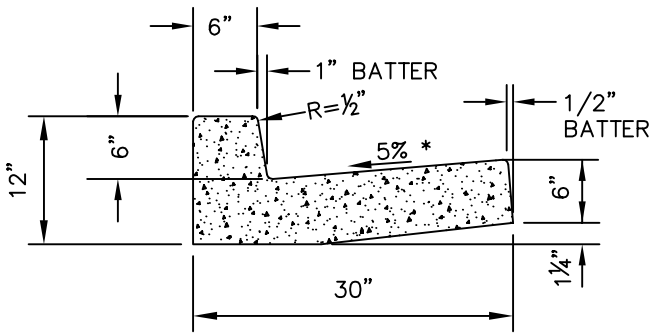

TYPE "A" CURB

* 3% MAX. AT CURB RAMPS

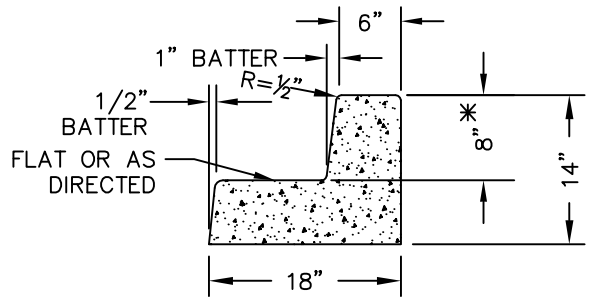

TYPE "B" CURB

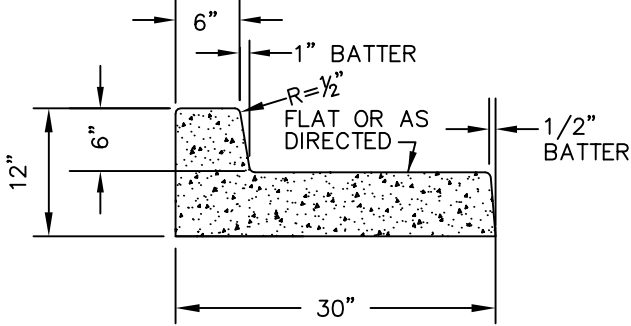

TYPE "C" CURB

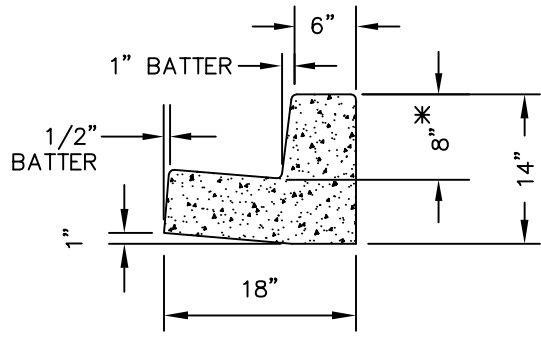

TYPE "D" CURB

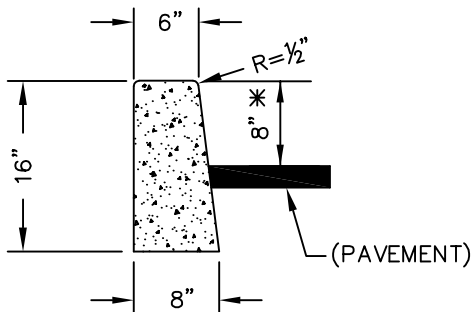

TYPE "E" CURB

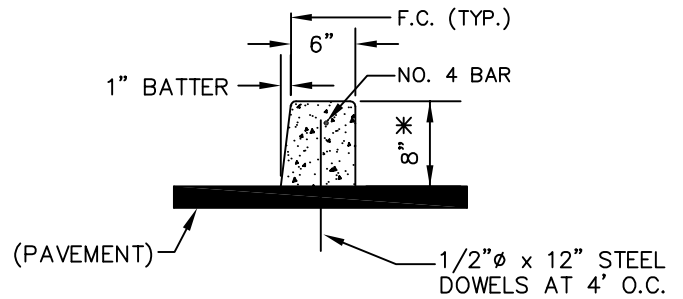

TYPE "F" CURB

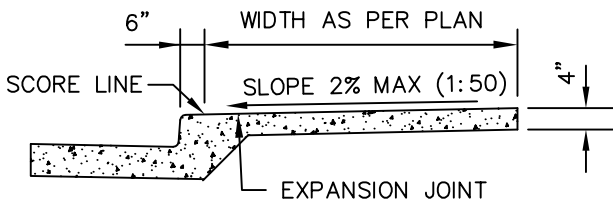

TYPE "A" SIDEWALK

POUR CURB & GUTTER SEPARATELY FROM SIDEWALK

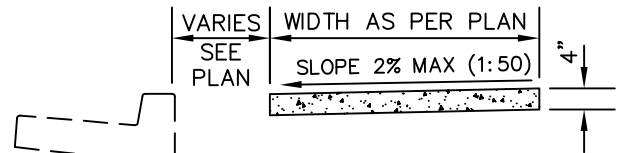

TYPE "B" SIDEWALK

POURED SEPARATE FROM CURB

NOTES:

1. SEE DRAWING NO. 100 FOR GENERAL REQUIREMENTS.
2. * 8" CURB HEIGHT UNLESS 6" HEIGHT APPROVED BY AGENCY ENGINEER.

UNIFORM STANDARDS
ALL CITIES AND
COUNTY OF MARIN

CURB, GUTTER
AND SIDEWALK
DETAILS

REV.	DATE	BY

MAY 2008

DWG. NO.

105

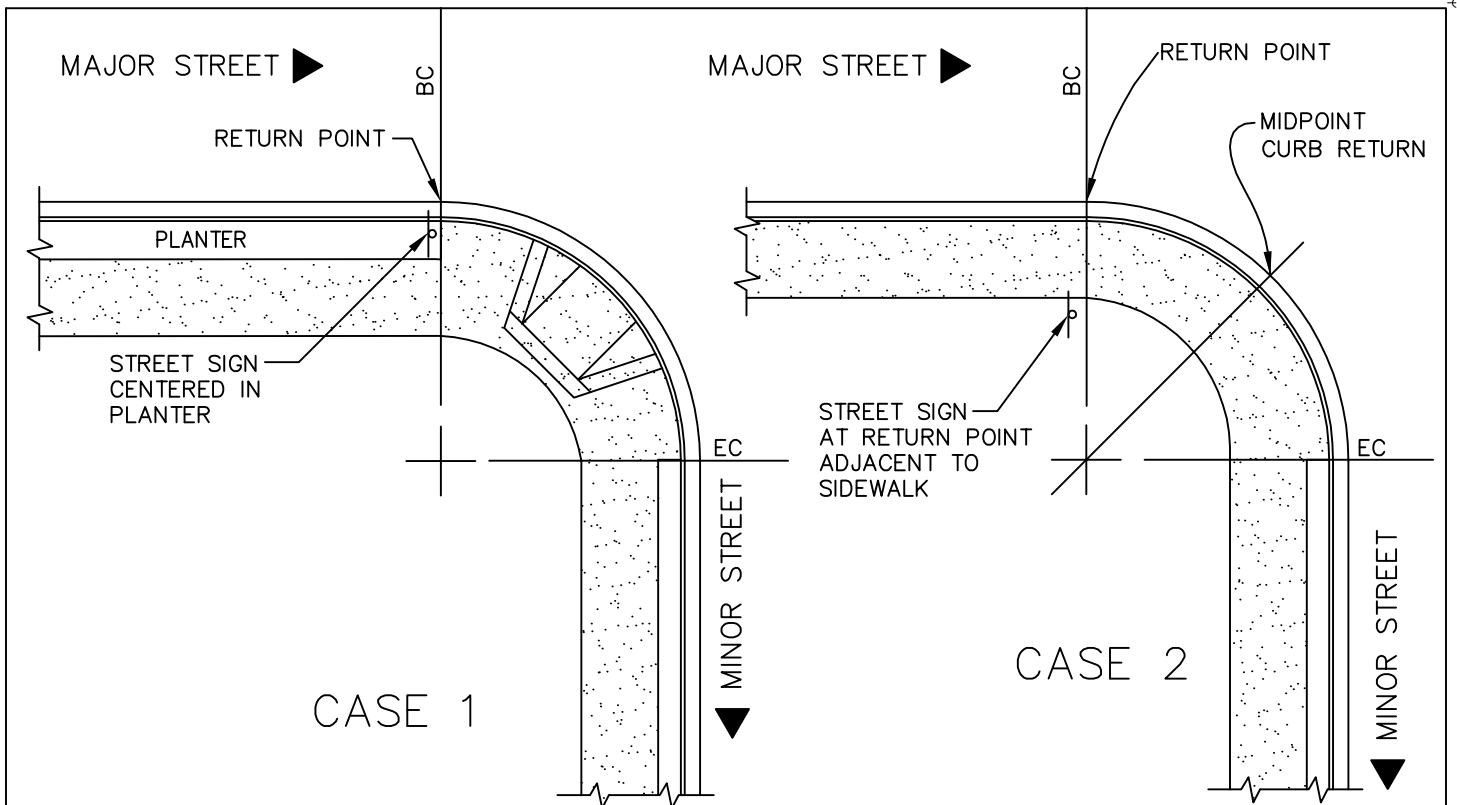

CASE 3 WHERE BOTH STREETS HAVE ADJACENT SIDEWALK – INSTALL STREET SIGN IN SAME LOCATION AS SHOWN IN CASE 2.

CASE 4 WHERE MAJOR STREET HAS NO SIDEWALK – STREET SIGN TO BE PLACED AT THE RETURN POINT ON THE MAJOR STREET 1’–6” BEHIND THE FACE OF CURB.

CASE 5 WHERE THERE IS NO CURB AND GUTTER – LOCATE STREET SIGN WHERE DIRECTED BY THE AGENCY ENGINEER.

NOTE:

1. THE NUMBER OF STREET SIGNS PER INTERSECTION WILL BE AS SHOWN ON THE PLANS OR DETERMINED BY THE AGENCY ENGINEER.

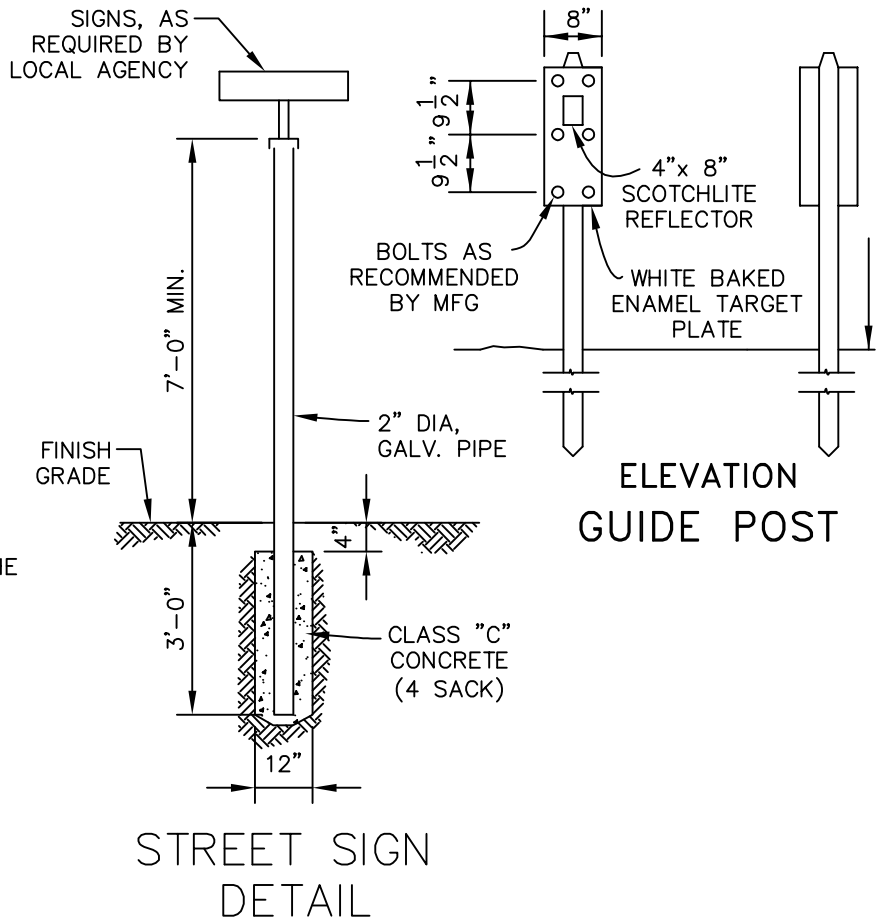

UNIFORM STANDARDS ALL CITIES AND COUNTY OF MARIN	STREET SIGNS				MAY 2008
					DWG. NO.
					310
		REV.	DATE	BY	

CENTERLINES
(2 LANE HIGHWAYS)

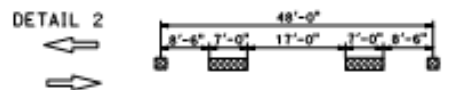
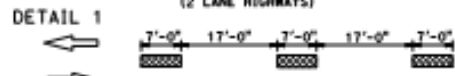

DETAIL 3 DELETED

DETAIL 4 DELETED

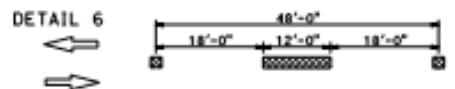

DETAIL 7 DELETED

LANELINES
(MULTILANE HIGHWAYS)

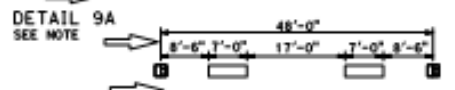
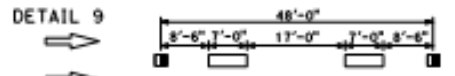
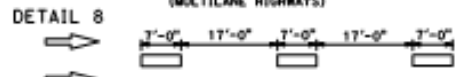

DETAIL 10 DELETED



LANELINES (Cont)
(MULTILANE HIGHWAYS)

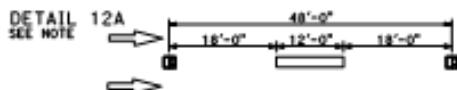
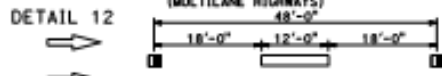

DETAIL 13 DELETED

DETAIL 14 DELETED

DETAIL 14A DELETED

NO PASSING ZONES-ONE DIRECTION

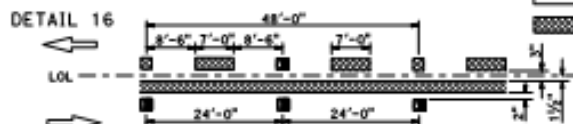
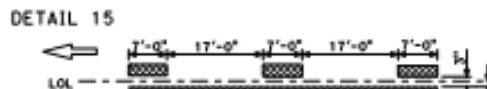

DETAIL 17 DELETED

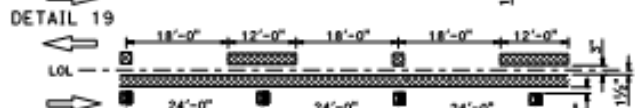
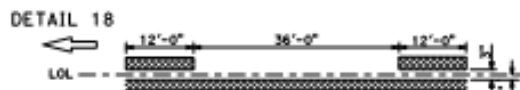

DETAIL 20 DELETED

NO PASSING ZONES-TWO DIRECTION

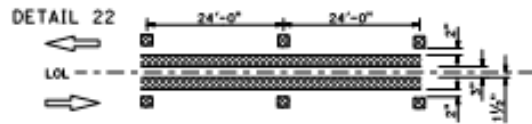

DETAIL 23 DELETED

LEGEND

MARKERS

- TYPE C RED-CLEAR RETROREFLECTIVE
- TYPE D TWO-WAY YELLOW RETROREFLECTIVE
- TYPE G ONE-WAY CLEAR RETROREFLECTIVE
- TYPE H ONE-WAY YELLOW RETROREFLECTIVE

LINES

- 6" WHITE
- 6" YELLOW

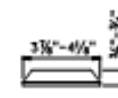
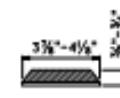

TYPE C AND TYPE D TYPE G AND TYPE H

RETROREFLECTIVE FACE

NOTE:
FOR FREEWAY APPLICATION ONLY

STATE OF CALIFORNIA
DEPARTMENT OF TRANSPORTATION
**PAVEMENT MARKERS
AND TRAFFIC LINES
TYPICAL DETAILS**

NO SCALE

A20A

SHEET NO.	COUNTY	ROUTE	FOOT MILES TOTAL PROJECT	SHEET TOTAL NO.	TOTAL SHEETS

Arthur Jensen
 REGISTERED CIVIL ENGINEER
 No. 31-18
 PLANS APPROVAL DATE
 May 31, 2018
 THE STATE OF CALIFORNIA OR ITS OFFICERS OR AGENTS SHALL NOT BE RESPONSIBLE FOR THE ACCURACY OR COMPLETENESS OF SCANNED COPIES OF THIS PLAN SHEET.

CHANNELIZING LINE

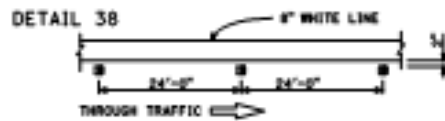

DETAIL-38C **DETAIL 38C DELETED**

BIKE LANE LINE



**INTERSECTION LINE
BIKE LANE**

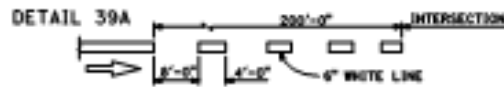

**LANE LINE EXTENSIONS
THROUGH INTERSECTIONS**



DETAIL-40A **DETAIL 40A DELETED**

**CENTER LINE EXTENSIONS
THROUGH INTERSECTIONS**



DETAIL-41A **DETAIL 41A DELETED**

LEGEND

MARKERS

- TYPE C RED-CLEAR RETROREFLECTIVE
- TYPE G ONE-WAY CLEAR RETROREFLECTIVE
- 6" YELLOW LINE

MARKER DETAILS

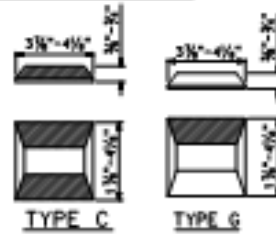

RETROREFLECTIVE FACE

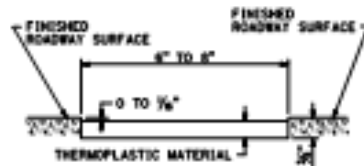

**DETAIL FOR RECESSED
THERMOELASTIC TRAFFIC STRIPE**

See Notes A and B.

RECESSED THERMOELASTIC NOTES

- A. See typical traffic line details for pavement marking patterns.
- B. The top of the thermoelastic installed in recessed pavement shall be 0 to 1/8" below the pavement surface.

DIST.	COUNTY	ROUTE	POST MILE	PROJECT TOTAL PROJECT	PROJECT TOTAL SHEETS

John J. [Signature]
REGISTERED CIVIL ENGINEER

May 31, 2018
PLANS APPROVAL DATE

STATE OF CALIFORNIA DEPARTMENT OF TRANSPORTATION
DIVISION OF HIGHWAYS
1000 CALIFORNIA STREET, SACRAMENTO, CA 95833

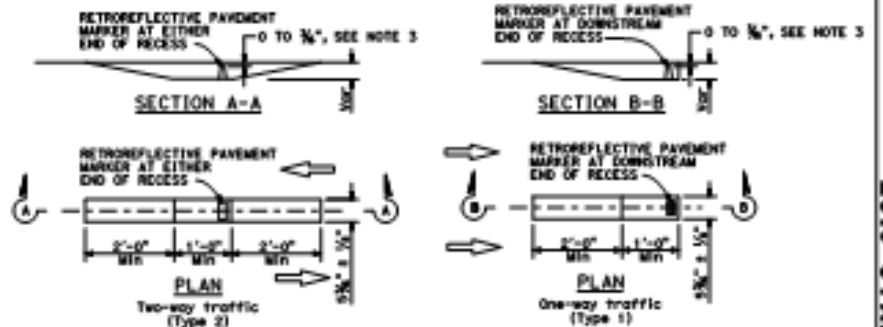

**RECESS DETAIL FOR
RETROREFLECTIVE PAVEMENT MARKER**

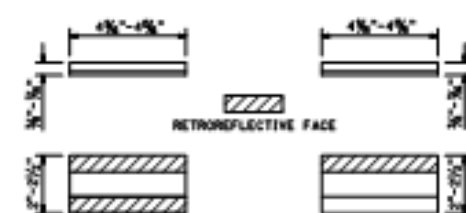

RECESSED MARKER NOTES:

- 1. See typical traffic line details for marker patterns to be used with recessed pavement markers. Detail 144 requires a Type 2 recess.
- 2. The retroreflective pavement markers shown for recessed installations are not to be used for non-recessed installations.
- 3. The top of pavement markers installed in recesses shall be 0 to 1/8" below the pavement surface.

TYPE C AND TYPE D TYPE G AND TYPE H
See Notes 1 and 2.

**RETROREFLECTIVE PAVEMENT MARKER
FOR RECESSED INSTALLATION**

STATE OF CALIFORNIA
DEPARTMENT OF TRANSPORTATION
**PAVEMENT MARKERS
AND TRAFFIC LINES
TYPICAL DETAILS**

NO SCALE

A200

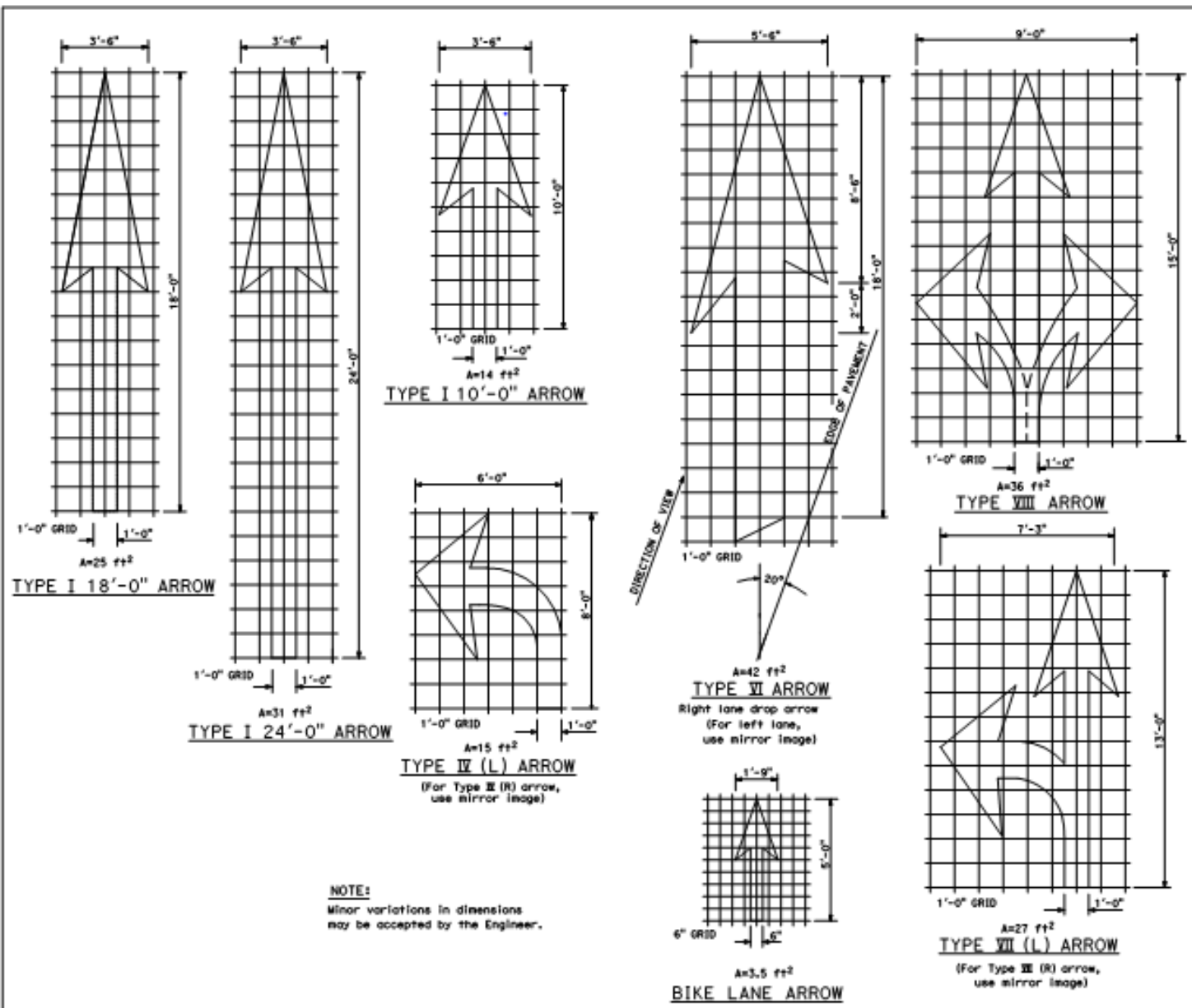

NOTE:
 Minor variations in dimensions may be accepted by the Engineer.

DIST.	COUNTY	ROUTE	POST MILES TOTAL PROJECT	SHEET NO.	TOTAL SHEETS

Orlando Torres
 REGISTERED CIVIL ENGINEER

May 31, 2018
 PLANS APPROVAL DATE

THE STATE OF CALIFORNIA BY ITS OFFICERS OF PUBLIC WORKS HAS REVIEWED THESE PLANS AND APPROVES THEM FOR THE PURPOSES OF COMPLETION OF STATED PURPOSES OF THIS PLAN SHEET.

Walter Egan
 CIVIL ENGINEER
 2-21-12
 STATE OF CALIFORNIA

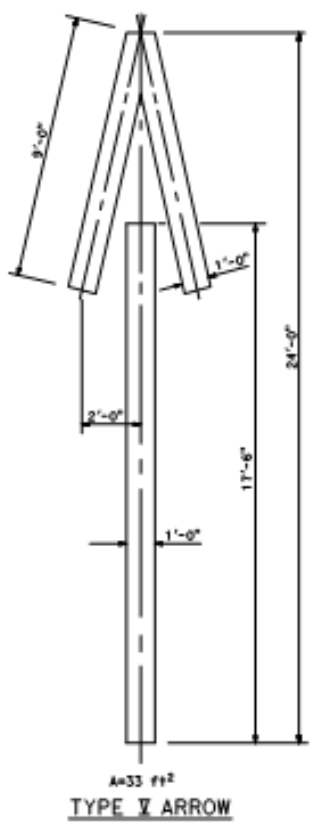

STATE OF CALIFORNIA
 DEPARTMENT OF TRANSPORTATION
**PAVEMENT MARKINGS
 ARROWS**
 NO SCALE

A24A

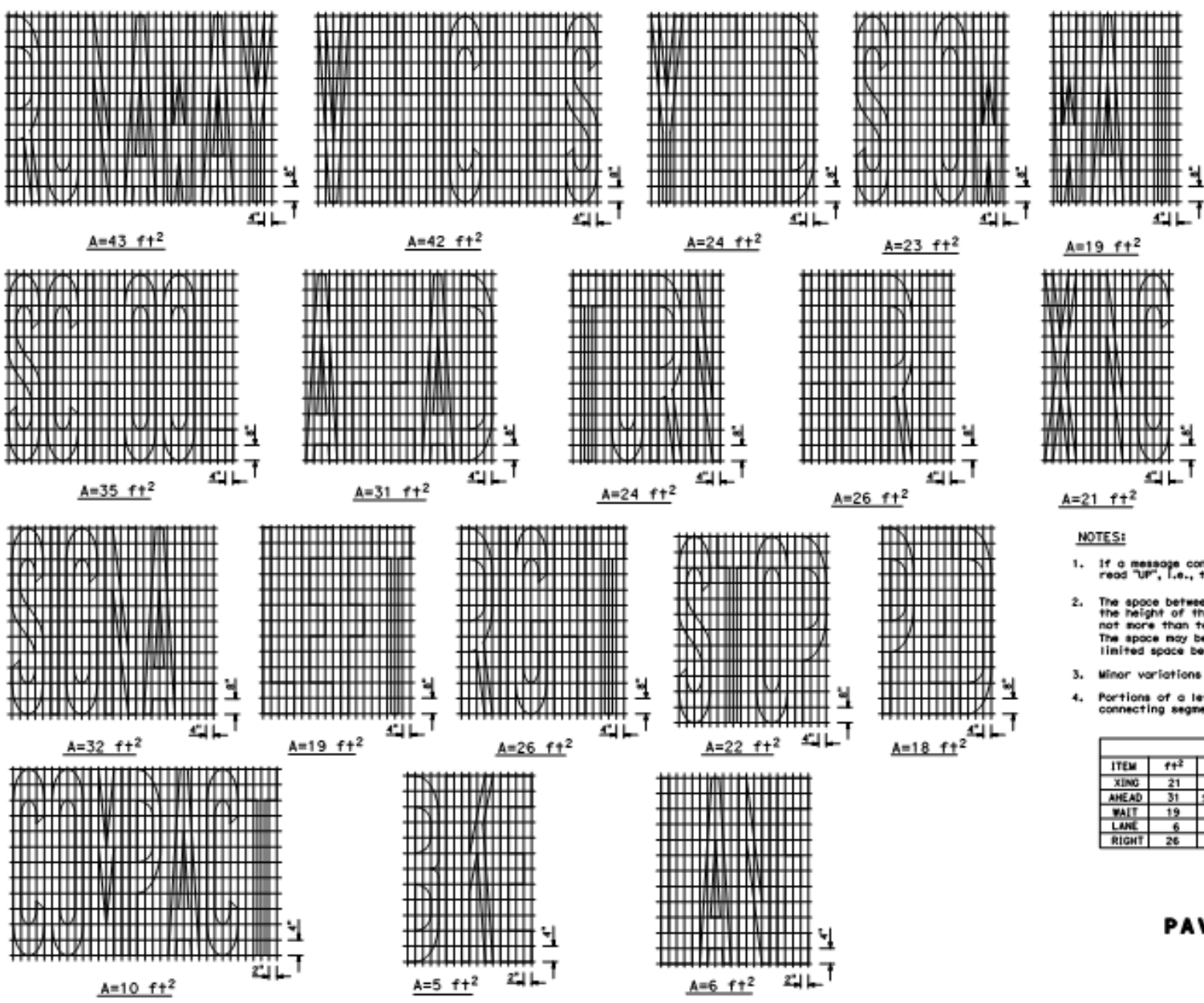

DIST.	COUNTY	ROUTE	POST MILES TOTAL PROJECT	SHEET NO.	TOTAL SHEETS

Alvin Jones
REGISTERED CIVIL ENGINEER

May 31, 2018
PLANS APPROVAL DATE

THE STATE OF CALIFORNIA, BY ITS OFFICERS OF HIGHWAYS SHALL NOT BE RESPONSIBLE FOR THE ACCURACY OR COMPLETION OF DRAWING COPIES OF THIS PLAN SHEET.

Wanda Farnum
REGISTERED PROFESSIONAL ENGINEER
CIVIL
No. 3-30-19
DIV. 1
STATE OF CALIFORNIA

NOTES:

1. If a message consists of more than one word, it must read "UP", i.e., the first word must be nearest the driver.
2. The space between words must be at least four times the height of the characters for low speed roads, but not more than ten times the height of the characters. The space may be reduced appropriately where there is limited space because of local conditions.
3. Minor variations in dimensions may be accepted by the Engineer.
4. Portions of a letter, number or symbol may be separated by connecting segments not to exceed 2" in width.

WORD MARKINGS							
ITEM	ft²	ITEM	ft²	ITEM	ft²	ITEM	ft²
XING	21	YIELD	24	BIKE	5	PED	18
AHEAD	31	SCHOOL	35	SLOW	23	COMPACT	10
WAIT	19	SIGNAL	32	STOP	22	RUNAWAY	43
LANE	6	TURN	24	LEFT	19	VEHICLES	42
RIGHT	26	HERE	26				

STATE OF CALIFORNIA
DEPARTMENT OF TRANSPORTATION
**PAVEMENT MARKINGS
WORDS**

NO SCALE

A24D

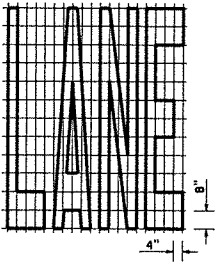

A=24 ft²

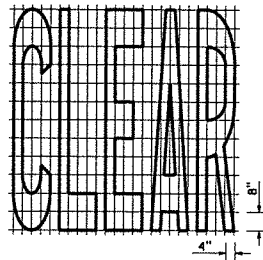

A=27 ft²

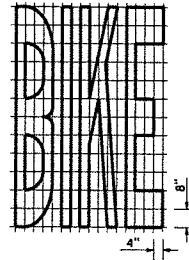

A=21 ft²

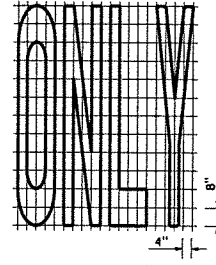

A=22 ft²

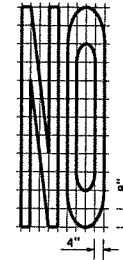

A=14 ft²

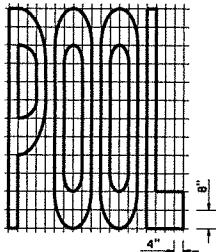

A=23 ft²

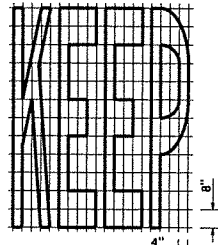

A=24 ft²

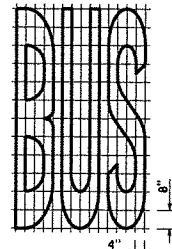

A=20 ft²

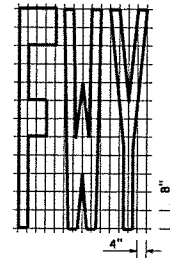

A=16 ft²

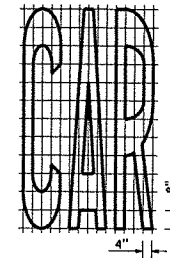

A=17 ft²

Dist	COUNTY	ROUTE	POST MILES TOTAL PROJECT	SHEET No.	TOTAL SHEETS

Atifa Ferouz
REGISTERED CIVIL ENGINEER

May 31, 2018
PLANS APPROVAL DATE

REGISTERED PROFESSIONAL ENGINEER
Atifa Ferouz
CBO402
Exp. 3-31-19
STATE OF CALIFORNIA

THE STATE OF CALIFORNIA OR ITS OFFICERS OR AGENTS SHALL NOT BE RESPONSIBLE FOR THE ACCURACY OR COMPLETENESS OF SCANNED COPIES OF THIS PLAN SHEET.

WORD MARKINGS			
ITEM	ft ²	ITEM	ft ²
LANE	24	NO	14
POOL	23	BIKE	21
CAR	17	BUS	20
CLEAR	27	ONLY	22
KEEP	24	FWY	16



A=2 ft²
See Notes 6 and 7

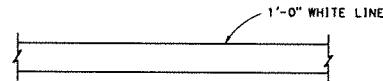

LIMIT LINE (STOP LINE)

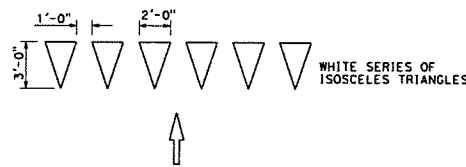

YIELD LINE

NOTES:

1. If a message consists of more than one word, it must read "UP", i.e., the first word must be nearest the driver.
2. The space between words must be at least four times the height of the characters for low speed roads, but not more than ten times the height of the characters. The space may be reduced appropriately where there is limited space because of local conditions.
3. Minor variations in dimensions may be accepted by the Engineer.
4. Portions of a letter, number or symbol may be separated by connecting segments not to exceed 2" in width.
5. The words "NO PARKING" pavement marking is to be used for parking facilities. For typical locations of markings, see Standard Plans A90A and A90B.
6. The words "NO PARKING", shall be painted in white letters no less than 1'-0" high on a contrasting background and located so that it is visible to traffic enforcement officials.

STATE OF CALIFORNIA
DEPARTMENT OF TRANSPORTATION
PAVEMENT MARKINGS
WORDS, LIMIT AND YIELD LINES

NO SCALE

A24E

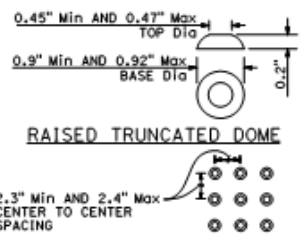
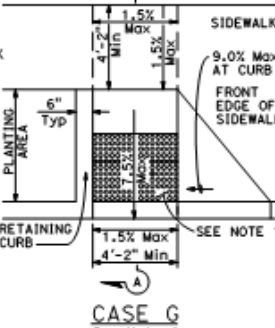
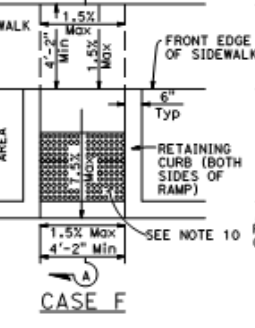
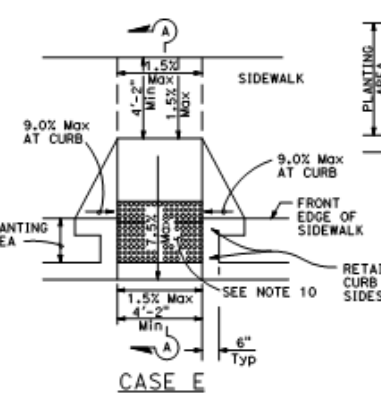
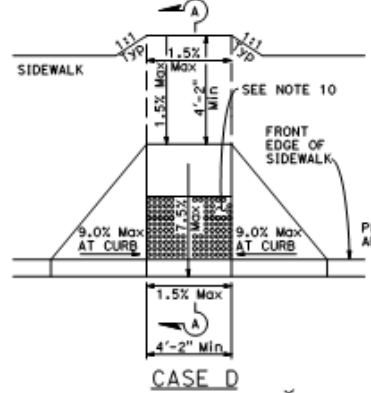
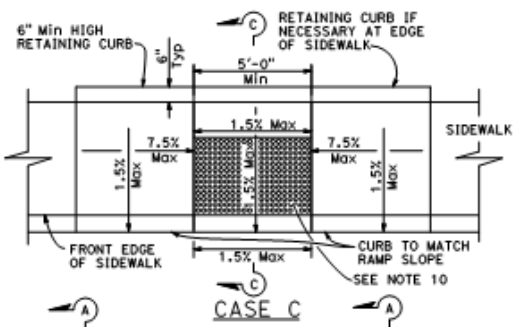
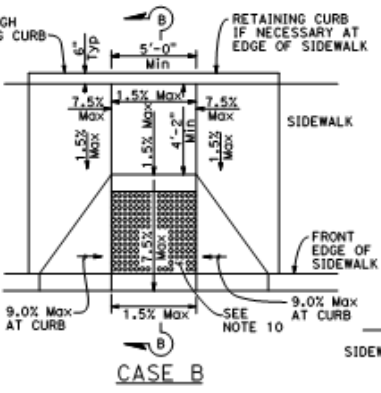
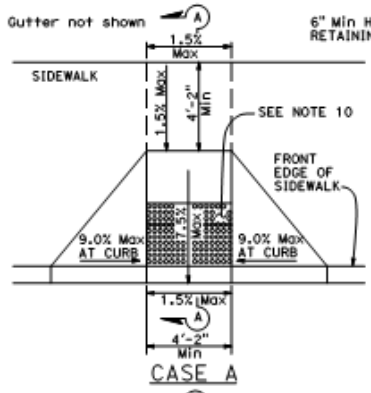

RAISED TRUNCATED DOME PATTERN (IN-LINE) DETECTABLE WARNING SURFACE

- NOTES:** See Note 10
- As site conditions dictate, Case A through Case G curb ramps may be used for corner installations similar to those shown in Detail A and Detail B. The case of curb ramps used in Detail A do not have to be the same. Case A through Case G curb ramps also may be used at mid block locations, as site conditions dictate. For specific site condition configuration, including the conform to existing sidewalk, see Project Plans.
 - If distance from curb to back of sidewalk is too short to accommodate ramp and 4'-2" platform (landing) as shown in Case A, the sidewalk may be depressed longitudinally as in Case B or C or may be widened as in Case D.
 - When ramp is located in center of curb return, crosswalk configuration must be similar to that shown for Detail B.
 - As site conditions dictate, the retaining curb side and the flared side of the Case G ramp shall be constructed in reversed position.
 - The ramp portion of the curb ramp is a typical rectangle, unless modified in the Project Plans.
 - Side slope of ramp flares vary uniformly from a maximum of 9.0% at curb to conform with longitudinal sidewalk slope adjacent to top of the ramp, except in Case C and Case F.
 - The adjacent surfaces at transitions at curb ramps to walks, gutters, and streets shall be at the same level.
 - Counter slopes of adjoining gutters and road surfaces immediately adjacent to and within 24 inches of the curb ramp shall not be steeper than 1:20H (5.0%). Gutter pan slope shall not exceed 1" of depth for each 2'-0" of width.
 - Transition gutter pan slope from 1" of depth for each 2'-0" of width to match typical gutter pan slope per Standard Plan AB7A.
 - The detectable warning surface will be a rectangle as shown at back of curb, unless modified in the Project Plans. Curb ramps shall have a detectable warning surface that extends the full width and 3'-0" depth of the ramp. Detectable warning surfaces shall extend the full width of the ramp except a maximum gap of 1 inch is allowed on each side of the ramp. Detectable warning surfaces shall conform to the requirements in the Standard Specifications.
 - Sidewalk and ramp thickness, "T", shall be 3/2" minimum.
 - Utility pull boxes, manholes, vaults and all other utility facilities within the boundaries of the curb ramp will be relocated or adjusted to grade by the owner prior to, or in conjunction with, curb ramp construction.
 - Detectable warning surface may have to be cut to allow removal of utility covers while maintaining detectable warning width and depth.

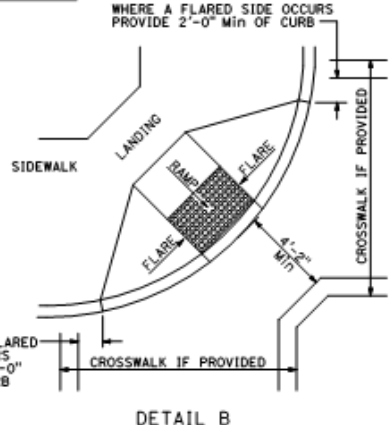
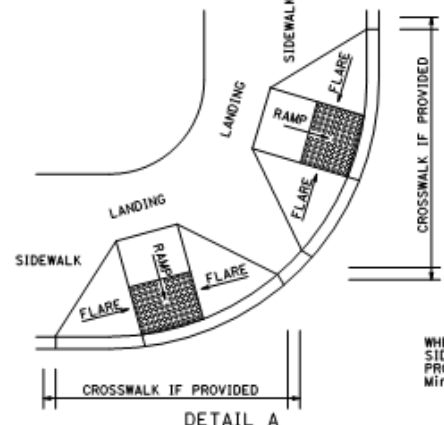
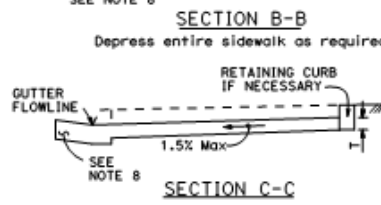
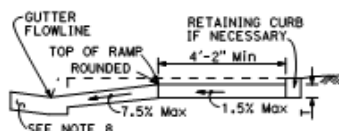
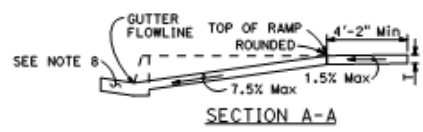

TYPICAL TWO-RAMP CORNER INSTALLATION

TYPICAL ONE-RAMP CORNER INSTALLATION

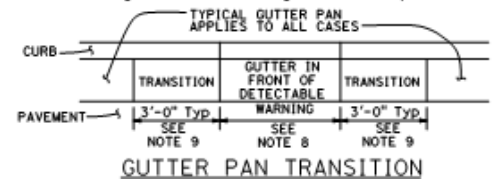

STATE OF CALIFORNIA
DEPARTMENT OF TRANSPORTATION
CURB RAMP DETAILS
NO SCALE

- City of Belvedere
- City of Larkspur
- City of Mill Valley
- City of Novato
- City of San Rafael *
- City of Sausalito

- Town of Ross
- Town of Fairfax
- Town of Corte Madera
- Town of San Anselmo
- Town of Tiburon
- County of Marin

EP No: _____
A / B

APPENDIX B - DRAFT ENCROACHMENT PERMIT

No. Street City/Township
\$

STARTING DATE: _____

PROPERTY OWNER'S NAME AND ADDRESS (If Different from Applicant):

Check all that apply to the project and provide a written description:

- | | | | |
|--------------------------------------------|----------------------------------------|------------------------------------------|-------------------------------------------|
| <input type="checkbox"/> Driveway Approach | <input type="checkbox"/> Sidewalk | <input type="checkbox"/> Accessible Ramp | <input type="checkbox"/> Debris Box |
| <input type="checkbox"/> Curb & Gutter | <input type="checkbox"/> Water Service | <input type="checkbox"/> New Utilities | <input type="checkbox"/> Special Event |
| <input type="checkbox"/> Sewer Improvement | <input type="checkbox"/> Excavation | <input type="checkbox"/> Landscaping | <input type="checkbox"/> Other (Describe) |

Road Surface Type: _____

Trenching Work: _____ Linear Feet: _____ Surface Thickness: _____

Applicant agrees that all work will be performed in accordance with the rules, regulations and standards of the Local Agency Department of Public Works and any Local Municipal Code. All work shall be subject to inspection and approval by the Department of Public Works. Applicant shall indemnify, defend and hold the Local Agency, its officers, agents and employees harmless from any and all claims, suits or liability, including, but not limited to, litigation costs and attorney's fees which the Local Agency may incur as the result of any and all claims and suits for personal injury, property damage or inverse condemnation by reason of applicants placement of/or maintenance of encroachments authorized by this permit. No work shall commence until permit is issued.

AGENCY: _____

- City of Belvedere
- City of Larkspur
- City of Mill Valley
- City of Novato
- City of San Rafael *
- City of Sausalito

- Town of Ross
- Town of Fairfax
- Town of Corte Madera
- Town of San Anselmo
- Town of Tiburon
- County of Marin

EP No: _____
A / B

**DRAFT ENCROACHMENT
PERMIT**

UNIFIED APPLICATION FOR ENCROACHMENT PERMIT

APPLICATION DATE: _____ APN: _____ - _____ - _____

LOCATION OF WORK OR ENCROACHMENT: _____

No. Street City/Township

CROSS STREET: _____ ESTIMATED COST: \$ _____

STARTING DATE: _____ COMPLETION DATE: _____

PROPERTY OWNER'S NAME AND ADDRESS (If Different from Applicant): _____

THE UNDERSIGNED HEREBY APPLIES FOR PERMISSION TO PERFORM THE FOLLOWING DESCRIBED WORK AND/OR OTHERWISE ENCROACH ON A LOCAL AGENCY RIGHT-OF-WAY (ROW):

DESCRIPTION OF WORK OR ENCROACHMENT (Include plans or sketch):

Check all that apply to the project and provide a written description:

- | | | | |
|--------------------------------------------|----------------------------------------|------------------------------------------|-------------------------------------------|
| <input type="checkbox"/> Driveway Approach | <input type="checkbox"/> Sidewalk | <input type="checkbox"/> Accessible Ramp | <input type="checkbox"/> Debris Box |
| <input type="checkbox"/> Curb & Gutter | <input type="checkbox"/> Water Service | <input type="checkbox"/> New Utilities | <input type="checkbox"/> Special Event |
| <input type="checkbox"/> Sewer Improvement | <input type="checkbox"/> Excavation | <input type="checkbox"/> Landscaping | <input type="checkbox"/> Other (Describe) |

Describe:

Road Surface Type: Asphalt Concrete Other: _____

Trenching Work: Yes No Linear Feet: _____ Surface Thickness: _____

Traffic Control Plan: Yes No

Applicant agrees that all work will be performed in accordance with the rules, regulations and standards of the Local Agency Department of Public Works and any Local Municipal Code. All work shall be subject to inspection and approval by the Department of Public Works. Applicant shall indemnify, defend and hold the Local Agency, its officers, agents and employees harmless from any and all claims, suits or liability, including, but not limited to, litigation costs and attorney's fees which the Local Agency may incur as the result of any and all claims and suits for personal injury, property damage or inverse condemnation by reason of applicants placement of/or maintenance of encroachments authorized by this permit. No work shall commence until permit is issued.

APPLICANT'S NAME / COMPANY (PLEASE PRINT): _____

CONTRACTOR'S NAME: _____ Contractor License No: _____

APPLICANT'S MAILING ADDRESS: _____

AGENCY: _____

CONTACT NUMBERS: _____

Daytime Phone Fax Email

APPLICANT'S SIGNATURE: _____

For Agency Use Only				Fees:
Accepted By: _____	Insurance on file? <input type="checkbox"/> Yes <input type="checkbox"/> No	Final Insp. Cleared: <input type="checkbox"/>	Application: _____	_____
Road Moratorium? <input type="checkbox"/> Yes <input type="checkbox"/> No	Receipt #: _____	Plan Review & Inspection: _____	Total: _____	_____

Encroachment Permit Conditions

- Construction Standard(s): _____
- Hard copy of the approved permit shall be on site at all times during work
- Comprehensive General Liability insurance in amounts not less than \$1,000,000 combined single limit applying to bodily injury, personal injury and property damage are required.
- Additional Insured Endorsement: The local agency must be named as an additionally insured on a separate endorsement sheet that modifies the general liability policy.
- Contact local Police Department, Fire Department, and Parking Services prior to start of work.
- The Contractor shall maintain local access and provide emergency vehicle access at all times.
- Compaction test is required and shall be submitted to local Public Works Department.
- Provide a traffic control plan per the Manual on Uniform Traffic Control Devices (MUTCD).
- Provide safe pedestrian and wheelchair access, per ADA and State requirements, during construction.
- All work shall be performed between the hours of 8am and 6pm.
- Please contact _____ prior to start of work and for final inspection.
- Planning review required: YES / NO
- Special Conditions: _____

Encroachment Permit Approval

Approved By: _____ Date: _____

Inspected By: _____ Date: _____

On the Wednesday of the week before expected street closure, notify construction management/inspector and City Staff

At the end of each working day, driveways shall be made accessible to vehicles by placing cut back or some other material acceptable to the engineer to create a ramp from road surface to lip of gutter.

Drop offs adjacent to pedestrian path of travel, parking stalls shall not be in excess of 4".

CITY OF SAUSALITO

STANDARD CONDITIONS FOR ENCROACHMENT PERMIT NO. _____

DESCRIPTION: _____

Condition Marked Apply to this Project

THIS ENCROACHMENT PERMIT IS GOOD FOR 6 MONTHS ___ ONE YEAR ___ 18 MONTHS ___ AS NOTED ON THE E.P.APPLICATION _____

- 1. This permit, or a complete copy, shall be kept at the work site at all times while work is being performed.
- 2. Notify Engineering Division staff at least 24 hours in advance of beginning work. _____ Engineer at (415) 289-4106 ext. 111 and/or _____ Sewer Systems Coordinator at (415) 289-4192.
- 3. Contractor is to comply with all requirement of Ordinance No. 1048 (Noise Ordinance) including limiting hours of work in residential areas between 8:00AM and 7:00PM, Monday through Friday, between 9:00AM and 5:00PM, Saturdays, ~~and between 9:00AM and 7:00PM, on City Holidays~~. No work is permitted on Sunday, except by owner occupant between 9:00AM and 7:00PM. **6pm**
or City Holidays
- 4. Permittee shall comply with all Federal State and local laws regulation and statutes applicable to the work being performed under this permit. This also includes compliance with the requirements and permit conditions of the State of California Division of Industrial Safety.
- 5. The Permittee shall repair or replace at the discretion of the City Engineer, any and all public facilities damaged as a result of Permittee's actions in connection with this permit, and shall guarantee repairs or replacements to all work done under this permit, as deemed necessary by the City Engineer for a period of one year after completion of said work.
- 6. All traffic control shall be performed in accordance with the requirements of the current edition of Caltrans publication, "California Manual on Uniform Traffic Devices, Part 6- Temporary Traffic Control" including all specified advance construction signs and channelization devices. Construction warning signs and channelization devices are to be sufficient to adequately inform and protect vehicles, bicycle and pedestrian traffic. Permittee shall have available a copy of the Manual for workers at the construction site at all times during the progress of the work.
- 7. Where excavations have been permitted in paved streets, Permittee shall place temporary informational signs at each end of the work in addition to those signs required by the "California Manual on Uniform Traffic Devices, Part 6- Temporary Traffic Control." Such informational signs shall be a minimum of 18 x 24 inches, clearly identify the owner of the facility for which the work is being done, and shall show a telephone number of the owner where the public may obtain information relative to the work being done.
- 8. Traffic shall be permitted to pass through the work area at all times unless otherwise permitted in writing by the City Engineer. Any street closures shall be approved in advance by the City Engineer.
- 9. If the City Engineer determines that public convenience or safety is being jeopardized by Permittee's actions or inactions, the City Engineer may order the condition remedied by either verbal or written communication to the Permittee. If Permittee fails to remedy the condition within eight hours of such notice, the City Engineer may, at his or her discretion, either remedy the condition or contract to remedy the condition, and the cost thereof, including administrative expenses shall be charged to the Permittee.
- 10. If any work is performed in the location of an existing pedestrian path of travel, the Contractor shall restore the path of travel compliant with all ADA accessibility standards.
- 11. Any pavement marking and/or legends which are damaged or removed shall be replaced in kind by the Contractor at his/her expense. The repainting of any street markings or legends shall be performed using City stencils:
- 12. Wherever new work crosses any existing ~~City~~ utilities, the Contractor shall pothole the existing ~~City~~ utilities and determine their actual depth so as to avoid hitting these facilities during excavation.
- 13. All AC or PCC to be removed is to be sawcut at the edges.
- 14. All new AC street trench resurfacing is to be placed in maximum lifts of 3 inches and the final surface is to be fog sealed (unless a sand or slurry seal is called for on the plans).

*

Per Contract Documents

CITY OF SAUSALITO

STANDARD CONDITIONS FOR ENCROACHMENT PERMIT NO. _____

- 15. All sections of curb, gutter and sidewalk to be replaced, shall have 12 inch long dowels (#4 reinforcing bars) inserted 6" into the existing concrete. A minimum of 2 dowels shall be placed into the curb and gutter. A minimum of 2 dowels shall be placed into sidewalk. Sidewalk dowel spacing shall be 24 inches on center.
- * 16. Portions of existing sidewalk or curb and gutter to be removed shall be removed to the nearest expansion joint or sawcut at an existing score mark. Sawcuts must be at least 1-1/2 inches deep.
- * 17. Concrete curbs, gutters and sidewalk shall consist of five sacks of cement per cubic yard with 3/8" maximum aggregate. ~~Two pounds of lampblack shall be added per cubic yard.~~ Slump shall not exceed 4 inches.
- 18. Special care shall be taken to match the existing finish, color, texture and score joining during replacement of the sidewalk.
- 19. Curb, gutter and sidewalk surfaces shall be broom finished unless otherwise approved by the City Engineer.
- 20. New sidewalk thickness shall be 4 inches minimum and driveway thickness shall be 6" minimum.
- 21. All excavations shall be backfilled and paved either temporarily or permanently at the end of each work day or covered with steel traffic plates held securely in place.
- * 22. All backfill placement shall be approved by the City Engineer prior to permanent pavement replacement.
- 23. Tree roots shall not be cut or in any way damaged by Permittee.
- * 24. Trench backfill shall be ~~either concrete slurry containing one sack of cement per cubic yard with 3/4 inch maximum aggregate size,~~ or Class 2 Aggregate Base compacted to 95% relative compaction as determined by California Test Method No. 216. All other trench details shall conform with Uniform Standard Drawing No. 330, 340 and 350 except as modified herein.
- * 25. Permittee shall bear the entire cost of restoring the street or other property of the City, to the satisfaction of the City Engineer.
- 26. Excavated materials, equipment, construction materials or other debris shall not be stored or stockpiled on public streets
- * 27. The top six inches of subgrade shall be compacted to at least 95% relative Compaction in accordance with California Test Method No. 236 and shall be dampened before placing concrete.
- * 28. Where unsuitable subgrade material is encountered, the City Engineer may require remedial work to be done, including, but not limited to, placing a layer of crushed rock under the concrete section.
- 29. Undercut subgrade for gutter or sidewalk shall be filled with Class 2 Aggregate Base.
- 30. Where trench excavation is longitudinal with the traffic lane and extends 100 feet or more, a 2" minimum thickness of asphalt concrete paving with pavement reinforcing fabric shall be placed across the entire width of the affected traffic lane upon completion of trench work. Existing surfacing shall be removed as necessary to maintain satisfactory cross slopes.
- 31. One-half inch thick expansion joints shall be placed on both sides of driveway approaches, curb and sidewalk return points and at 4 feet on center. Weakened plane joints in sidewalk shall be at least 1-1/2 inch deep and placed at 16 feet on center.
- 32. All work shall be performed in accordance with the codes and ordinances of the City of Sausalito and the Uniform Construction Standards, Specifications of the Cities of Marin and County of Marin.
- 33. The Contractor is to provide a Storm Water Pollution Prevention Plan to the City for review and approval. City Approval must be obtained prior to commencing any work.
- 34. Underground Service Alert (USA) shall be notified at tel. (800) 642-2444, no later than 48 hours prior to excavation near utilities.
- 35. No new utility boxes or poles will be permitted in the sidewalk area without the written approval of the City Engineer.

*

Per Contract Documents

Special Conditions

- 1 The Encroachment Permit is only applicable to the public right of way; shall be responsible for ensuring that they have obtained permission from property owners prior to the use of their land.
- 2 No non-stormwater discharge shall enter the public storm drainage system or the Waters of The State. All Porta-Potties in the public Right of Way shall be equipped with a functional Secondary Containment Systems. The porta-potties shall be cleaned and maintained regularly throughout the project. The secondary containment shall be kept clear of trash, debris, and sewage. the secondary containment shall be properly cleaned or covered prior to any wet weather.
- 3 The public right of way shall be kept clean at all times. Spilled debris shall be cleaned promptly. No visible accumulation of sediment is permitted. No washing of sediment into drainage inlets is permitted. No materials associated with the work shall enter the waters of the State.
- 4 Prevent construction equipment/materials from entering stormdrains, sanitary sewers, ditches, creeks, or the bay.
- 5 Sweep streets and other paved areas daily. Never wash down streets or work areas with water.
- 6 Store any stockpiles of dirt, sand, asphalt, concrete, grout, or mortar under cover and away from drainage areas. These materials must never reach a storm drain, or other watercourse.
- 7 Contractor shall provide constant dust control.
- 8 Open Excavation(s) shall not be left unattended.
- 9 Trench plates shall be non-skid and anchored with railroad spikes or better. Trench plates within the sidewalk shall have less than one half inch vertical difference between the existing sidewalk and top of trench plates. Any vertical difference greater than one quarter inch shall comply with the attached Figure 11B-303.2 & 11B-303.3 the 2016 California Building Code, Change in Level.
- 10 Contractor shall save and protect existing monuments. Any damaged monuments shall be reestablished along with the filing of all required documents including but not limited to Corner Record with Marin County Department of Public Works. Refer to Business & Professions code section 8771.
- 11 Maintain access to adjacent driveways to maximum extent possible. Notify residents/property owners 48 hrs in advance should access to and from driveways will not be possible for an extended period of time.
- 12 No parking signs shall be obtained from City of Sausalito Department of Public Works one week in advance. Vehicles shall be parked legally in the parking spaces. No parking signs shall be posted and verified by the County Dispatch 72 hours prior to becoming effective for enforcement. To verify the no parking signs, call County Dispatch 415-499-7234.
- 13 Project shall not increase emergency response time and shall allow emergency vehicles to pass without delay.
- 14 The pedestrian barricade shall be 34 to 38 inches high. Pedestrian barricade rail supports shall not extend into the pedestrian walkway more than 4 inches. The top edge of the bottom portion of the barricade shall be a minimum of 8 inches above the walkway. The bottom edge of the barricade may only be a maximum of 2 inches above the surface of the walkway. Joints between barricades shall interlock or be closed flush, so that small wheels and canes cannot get caught on edges.

- 15 Contractor shall notify County Dispatch prior to any road closure: 415-499-7234 & provide road closure schedule. After calling County Dispatch, notify Department of Public Works at ENGINEERING@SAUSALITO.GOV If the road closure schedule changes, notify County Dispatch. After calling County Dispatch, notify Department of Public Works at ENGINEERING@SAUSALITO.GOV
- 16 Contractor shall provide an emergency contact phone number to County Dispatch. Emergency contact phone shall be monitored at all times while traffic control is in place.
- 17 Signs stating the date, time, location, contact name and phone number of responsible person in charge of the operation shall be posted, minimum one in each direction, at least 48 hours in advance of the closure. Signs shall consist of black letters on a white background, shall be at least two feet times four feet in size.
- 18 Contractor shall minimize the amount of time streets are closed and shall allow traffic to pass through the work area with a minimum of delay as soon as safely practical.
- 19 The Equipment shall not block the gutter.
- 20 Reflector/cones shall be placed at the traffic side corners of the Equipment.
- 21 The stockpiles shall be covered when not actively being accessed.
- 22 If a subcontractor is to be used to perform any part of the work, subcontractor shall name the City of Sausalito as an additionally insured on a separate endorsement sheet that modifies the general liability policy prior to start of work, a copy of which shall be provided to the City of Sausalito. The description in the certificate shall include the following language: "The City of Sausalito, its agents, officers, officials employees and volunteers as required by the permit are included as additionally insured."



Marin County Stormwater Pollution Prevention Program

Minimum Control Measures For Small Construction Projects

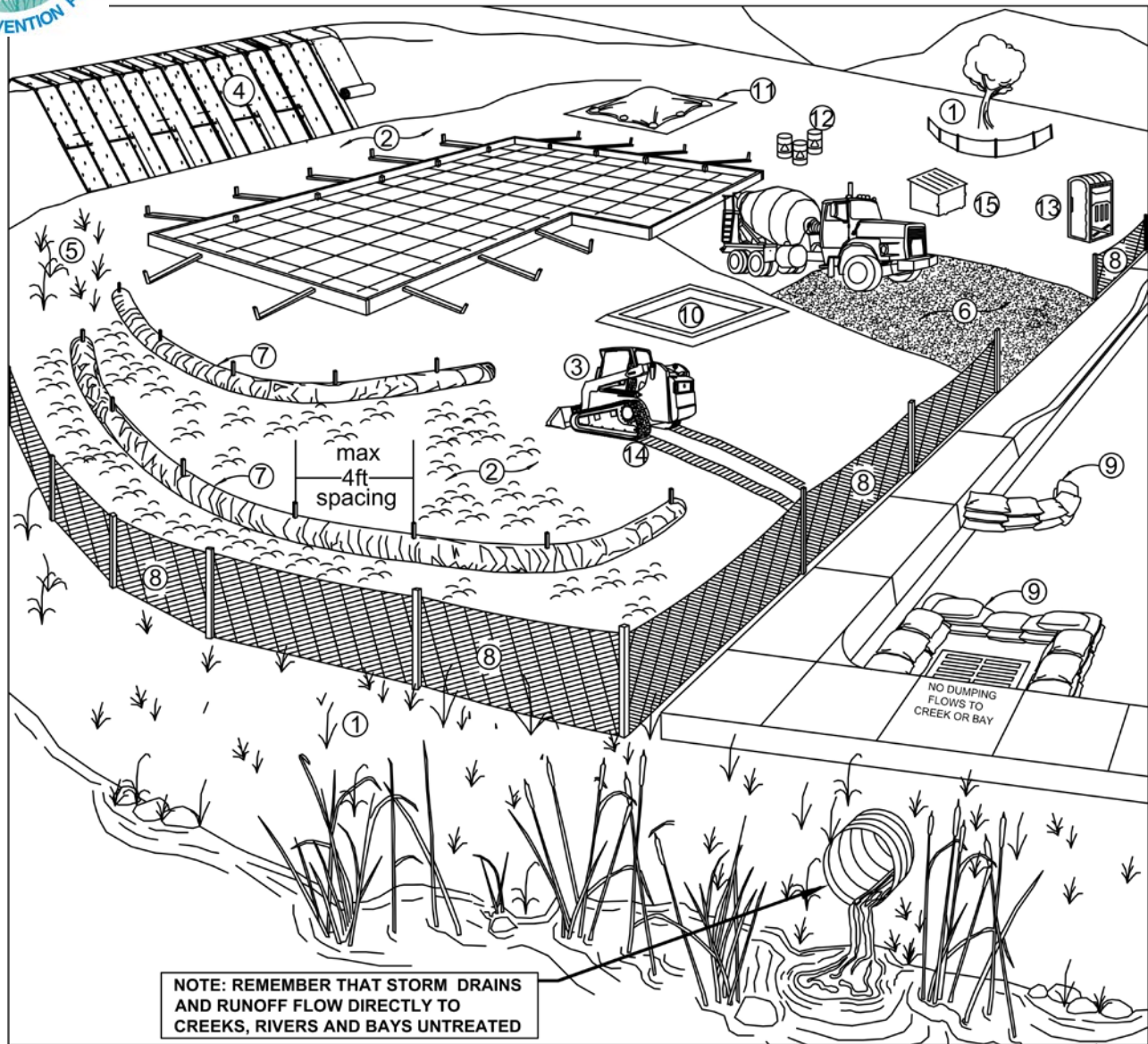

NOTE: REMEMBER THAT STORM DRAINS AND RUNOFF FLOW DIRECTLY TO CREEKS, RIVERS AND BAYS UNTREATED

<u>Erosion Controls</u>	<u>Sediment Controls</u>	<u>Good Housekeeping</u>
NS Scheduling	6. Tracking Controls	10. Concrete Washout
1. Preserve Vegetation & Creek Set Backs	7. Fiber Rolls	11. Stockpile Management
2. Soil Cover	8. Silt Fence	12. Hazardous Material Management
3. Soil Preparation/ Roughening	9. Drain Inlet Protection	13. Sanitary Waste Management
4. Erosion Control Blankets	NS Trench Dewatering	14. Equipment and Vehicle Maintenance
5. Revegetation		15. Litter and Waste Management

NS=not shown on graphic

Note: Select an **effective combination of control measures from each category**, Erosion Control, Sediment Control, and Good Housekeeping. Control measures shall be **continually implemented and maintained throughout the project** until activities are complete, disturbed areas are stabilized with permanent erosion controls, and the local agency has signed off on permits that may have been required for the project. **Inspect and maintain the control measures** before and after rain events, and as required by the local agency or state permit.

More detailed information on the BMPs can be found in the related California Stormwater Quality Association (CASQA) and California Department of Transportation (Caltrans) BMP Factsheets. CASQA factsheets are available by subscription in the *California Best Management Practices Handbook Portal: Construction* at <http://www.casqa.org>. Caltrans factsheets are available in the *Construction Site BMP Manual March 2003* at <http://www.dot.ca.gov/hq/construc/stormwater/manuals.htm>.

Visit www.mcstoppp.org for more information on construction site management and Erosion and Sediment Control Plans.

If you require materials in alternative formats, please contact:
415-473-4381 voice/TTY or disabilityaccess@co.marin.ca.us

Control Measure		General Description
Erosion Control Best Management Practices		
N/A	Scheduling	Plan the project and develop a schedule showing each phase of construction. Schedule construction activities to reduce erosion potential, such as scheduling ground disturbing activities during the summer and phasing projects to minimize the amount of area disturbed. <i>For more info see the following factsheets: CASQA: EC-1; or Caltrans: SS-1.</i>
1	Preserve Existing Vegetation and Creek Setbacks	Preserve existing vegetation to the extent possible, especially along creek buffers. Show creek buffers on maps and identify areas to be preserved in the field with temporary fencing. Check with the local Planning and Public Works Departments for specific creek set back requirements. <i>For more info see the following factsheets: CASQA: EC-2; or Caltrans: SS-2.</i>
2	Soil Cover	Cover exposed soil with straw mulch and tackifier (or equivalent). <i>For more info see the following factsheets: CASQA: EC-3, EC-5, EC-6, EC-7, EC-8, EC-14, EC-16; or Caltrans: SS-2, SS-4, SS-5, SS-6, SS-7, SS-8.</i>
3	Soil Preparation/Roughening	Soil preparation is essential to vegetation establishment and BMP installation. It includes soil testing and amendments to promote vegetation growth as well as roughening surface soils by mechanical methods (decompacting, scarifying, stair stepping, etc.). <i>For more info see the following factsheets: CASQA: EC-15.</i>
4	Erosion Control Blankets	Install erosion control blankets (or equivalent) on disturbed sites with 3:1 slopes or steeper. Use wildlife-friendly blankets made of biodegradable natural materials. Avoid using blankets made with plastic netting or fixed aperture netting. See: http://www.coastal.ca.gov/nps/Wildlife-Friendly_Products.pdf . <i>For more info see the following factsheets: CASQA: EC-7; or Caltrans: SS-7.</i>
5	Revegetation	Re-vegetate areas of disturbed soil or vegetation as soon as practical. <i>For more info see the following factsheets: CASQA: EC-4; or Caltrans: SS-4.</i>
Sediment Control Best Management Practices		
6	Tracking Controls	Stabilize site entrance to prevent tracking soil offsite. Inspect streets daily and sweep street as needed. Require vehicles and workers to use stabilized entrance. Place crushed rock 12-inches deep over a geotextile, using angular rock between 4 and 6-in. Make the entrance as long as can be accommodated on the site, ideally long enough for 2 revolutions of the maximum tire size (16-20 feet long for most light trucks). Make the entrance wide enough to accommodate the largest vehicle that will access the site, ideally 10 feet wide with sufficient radii for turning in and out of the site. Rumble pads or rumble racks can be used in lieu of or in conjunction with rock entrances. Wheel washes may be needed where space is limited or where the site entrance and sweeping is not effective. <i>For more info see the following factsheets: CASQA: TC-1; TC-3; or Caltrans: TC-1; TC-3.</i>
7	Fiber Rolls	Use fiber rolls as a perimeter control measure, along contours of slopes, and around soil stockpiles. On slopes space rolls 10 to 20 feet apart (using closer spacing on steeper slopes). Install parallel to contour. If more than one roll is used in a row overlap roll do not abut. J-hook end of roll upslope. Install rolls per either Type 1 (stake rolls into shallow trenches) or Type 2 (stake in front and behind roll and lash with rope). Use wildlife-friendly fiber rolls made of biodegradable natural materials. Avoid using fiber rolls made with plastic netting or fixed aperture netting. See: http://www.coastal.ca.gov/nps/Wildlife-Friendly_Products.pdf . Manufactured linear sediment control or compost socks can be used in lieu of fiber rolls. <i>For more info see the following factsheets: CASQA: SE-5 (Type 1); SE-12, SE-13; or Caltrans: SC-5 (Type 1 and Type 2).</i>
8	Silt Fence	Use silt fence as a perimeter control measure, and around soil stockpiles. Install silt fence along contours. Key silt fence into the soil and stake. Do not use silt fence for concentrated water flows. Install fence at least 3 feet back from the slope to allow for sediment storage. Wire backed fence can be used for extra strength. Avoid installing silt fence on slopes because they are hard to maintain. Manufactured linear sediment control can be used in lieu of silt fences. <i>For more info see the following factsheets: CASQA: SE-1; SE-12; or Caltrans: SC-1.</i>
9	Drain Inlet Protection	Use gravel bags, (or similar product) around drain inlets located both onsite and in gutter as a last line of defense. Bags should be made of a woven fabric resistant to photo-degradation filled with 0.5-1-in washed crushed rock. Do not use sand bags or silt fence fabric for drain inlet protection. <i>For more info see the following factsheets: CASQA: SE-10; or Caltrans: SC-10.</i>
N/A	Trench Dewatering	Follow MCSTOPPP BMPs for trench dewatering. http://www.marincounty.org/depts/pw/divisions/mcstoppp/development/-/media/Files/Departments/PW/mcstoppp/development/TrenchingSWReqMCSTOPPPFinal6_09.pdf . <i>For more info see the following factsheets: CASQA: NS-2; or Caltrans: NS-2.</i>
Good Housekeeping Best Management Practices		
10	Concrete Washout	Construct a lined concrete washout site away from storm drains, waterbodies, or other drainages. Ideally, place adjacent to stabilized entrance. Clean as needed and remove at end of project. <i>For more info see the following factsheets: CASQA: WM-8; or Caltrans: WM-8.</i>
11	Stockpile Management	Cover all stockpiles and landscape material and berm properly with fiber rolls or sand bags. Keep behind the site perimeter control and away from waterbodies. <i>For more info see the following factsheets: CASQA: WM-3 or Caltrans: WM-3.</i>
12	Hazardous Material Management	Hazardous materials must be kept in closed containers that are covered and within secondary containment; do not place containers directly on soil. <i>For more info see the following factsheets: CASQA: WM-6; or Caltrans: WM-6.</i>
13	Sanitary Waste Management	Place portable toilets near stabilized site entrance, behind the curb and away from gutters, storm drain inlets, and waterbodies. Tie or stake portable toilets to prevent tipping and equip units with overflow pan/tray (most vendors provide these). <i>For more info see the following factsheets: CASQA: WM-9; or Caltrans: WM-9.</i>
14	Equipment and Vehicle Maintenance	Prevent equipment fluid leaks onto ground by placing drip pans or plastic tarps under equipment. Immediately clean up any spills or drips. <i>For more info see the following factsheets: CASQA: NS-8, NS-9, and NS-10; or Caltrans: NS-8, NS-9, and NS-10.</i>
15	Litter and Waste Management	Designate waste collection areas on site. Use watertight dumpsters and trash cans; inspect for leaks. Cover at the end of each work day and when it is raining or windy. Arrange for regular waste collection. Pick up site litter daily. <i>For more info see the following factsheets: CASQA: WM-5; or Caltrans: WM-5.</i>

Notes:

- Mats/blankets should be installed vertically downslope
- Staple blankets sufficiently to ensure that material will maintain direct contact with soil

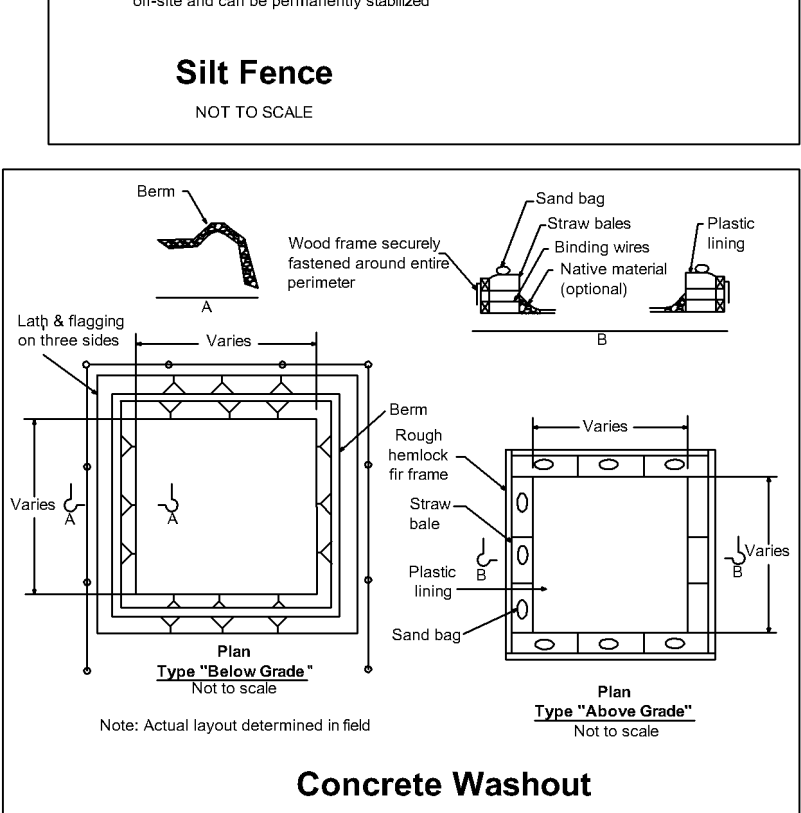
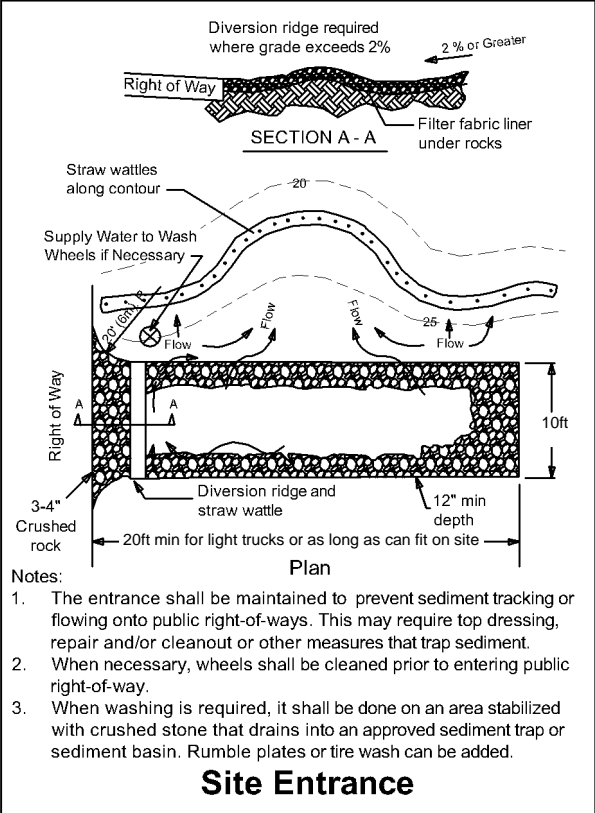
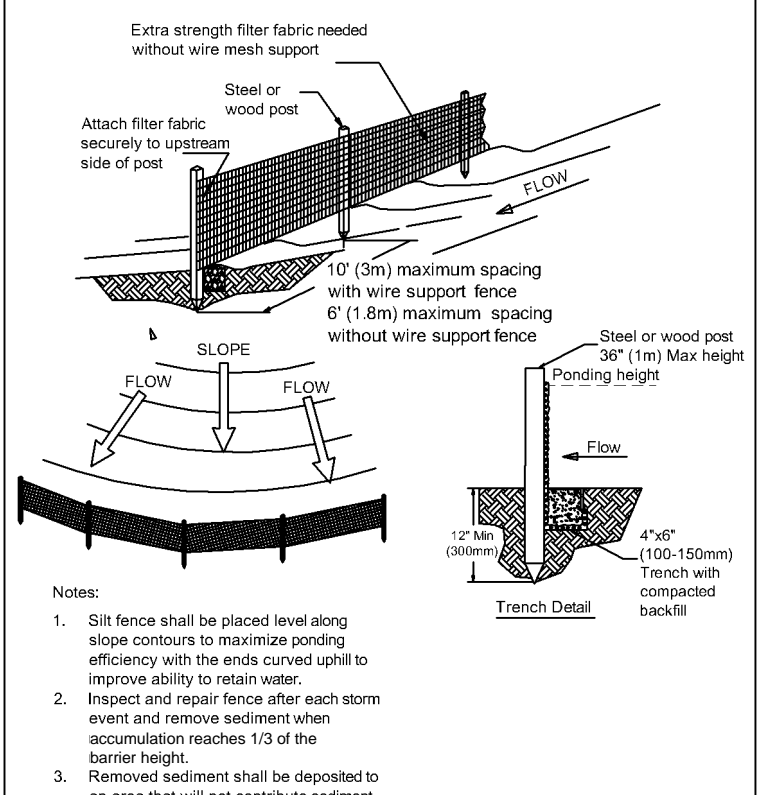
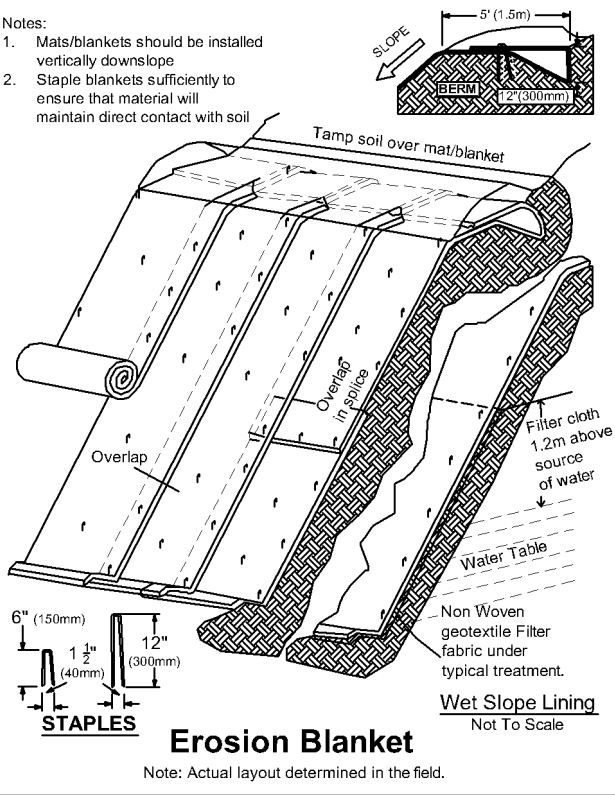

POLLUTION PREVENTION

IT'S PART OF THE PLAN

MAKE SURE YOUR CREWS AND SUBS DO THE JOB RIGHT!

Runoff from streets and other paved areas is a major source of pollution in San Francisco Bay. Construction activities can directly affect the health of the Bay unless contractors and crews plan ahead to keep dirt, debris, and other construction waste away from storm drains and local creeks. Following these guidelines will ensure your compliance with local ordinance requirements. Contact your local stormwater coordinator (see reverse). Storm drain polluters may be liable for fines!

EARTHWORK & CONTAMINATED SOILS

- ▶ Avoid scheduling earth disturbing activities during the rainy season if possible. If grading activities during wet weather are allowed in your permit, be sure to implement all measures necessary to prevent erosion.
- ▶ Mature vegetation is the best form of erosion control. Minimize disturbance to existing vegetation whenever possible.
- ▶ If you disturb a slope during construction, prevent erosion by securing the soil with erosion control fabric, or seed with fast-growing grasses as soon as possible. Place a silt barrier downslope until soil is secure.
- ▶ Keep excavated soil on the site where it is least likely to collect in the street. Transfer to dump trucks should occur on the site, not in the street.
- ▶ Use sand bags, silt fences, hay bales, straw logs or other control measures to prevent the flow of silt off the site and into storm drains or creeks.

PAVING/ASPHALT WORK

- ▶ Do not pave during wet weather or when rain is forecast.
- ▶ Always cover storm drain inlets and manholes when paving or applying seal coat, tack coat, slurry seal, or fog seal.
- ▶ Do not sweep or wash down excess materials into storm drains, ditches or creeks. Collect these materials and return them to stockpiles, or dispose of as trash.
- ▶ Do not use water to wash down fresh asphalt or concrete pavement.

DEWATERING OPERATIONS

- ▶ Reuse water for dust control, irrigation, or another on-site purpose to the greatest extent possible.
- ▶ Be sure to call the local Stormwater Coordinator before discharging water to a street, storm drain, or creek. Filtration or diversion through a basin, tank, or sediment trap may be required.

MATERIALS STORAGE & WASTE DISPOSAL

- ▶ Sweep streets and other paved areas daily. Never wash down streets or work areas with water!
- ▶ Be sure to store any stockpiles of dirt, sand, asphalt, concrete, grout, or mortar under cover and away from drainage areas. These materials must never reach a storm drain, or other watercourse.
- ▶ Wash out concrete equipment trucks off-site, or designate an on-site area for washing where water will flow into a temporary pit in a dirt area. Let the water seep into the soil and dispose of hardened concrete with trash.
- ▶ Divert water from washing exposed aggregate concrete to a dirt area where it will not run into a gutter, street, or storm drain.
- ▶ If a suitable dirt area is not available, collect the wash water and remove it for appropriate disposal off site.

HAZARDOUS MATERIALS MANAGEMENT

- ▶ Label all hazardous materials/wastes (such as pesticides, paints, thinners, solvents, fuel, oil, and antifreeze) in accordance with city, state, and federal regulations.
- ▶ Store hazardous materials and wastes in secondary containment and cover them during wet weather.
- ▶ Follow manufacturer's application instructions for hazardous materials. Be careful not to use more than necessary.
- ▶ Do not apply chemicals outdoors when rain is forecast within 24 hours.
- ▶ Dispose of hazardous materials/waste at the Hazardous Waste Collection Facility. For more information:
Novato businesses call 892-6395
All other businesses in Marin call 485-5648

CONTINUED ON BACK

PAINTING

- ▶ Never rinse paint brushes or materials into a storm drain or on the street!
- ▶ Paint out excess water-based paint before rinsing brushes, rollers, or containers in a sink. If you can't use a sink, direct wash water to a dirt area, and spade it into the dirt with a shovel.
- ▶ Paint out excess oil-based paint before cleaning brushes in paint thinner.
- ▶ Filter paint thinners and solvents for reuse whenever possible. Dispose of oil-based paint sludge and unusable thinner at the hazardous waste collection facility. (See reverse for Hazardous Materials Management.)

LANDSCAPING

- ▶ Schedule grading and excavation projects for dry weather.
- ▶ Protect stockpiles and landscaping materials from wind and rain by storing them under tarps and secured plastic sheeting.
- ▶ Store pesticides, fertilizers, and other chemicals indoors or in a locked shed or storage cabinet.
- ▶ Make sure products are properly labeled and check inventory before buying additional products.
- ▶ Rinse containers and use rinse water as products before tossing out empty containers (5 gallons or less) in the trash.
- ▶ Get rid of unwanted products through the hazardous waste facility. (See reverse for Hazardous Materials Management.)
- ▶ Use temporary check dams or ditches to divert runoff away from storm drains.
- ▶ Protect storm drain inlets with berms, filter mats or other inlet protection measures.
- ▶ Revegetate the area. It's an excellent form of erosion control for any site.
- ▶ Collect lawn and garden clippings, pruning waste and tree trimmings. Chip, if necessary, and compost.
- ▶ Do not place yard waste in gutters. In communities with curbside yard waste recycling, leave clippings and pruning waste for pick-up in approved bags or containers or, take to a landfill that composts yard waste.
- ▶ Do not blow or rake leaves into the street.
- ▶ Call the County Stormwater Program at 499-6528 and ask for a copy of "Here's What To Do with the Water" or look in "other businesses" under www.mcstoppp.org

POOL/FOUNTAIN/SPA MAINTENANCE

- ▶ Never discharge pool or spa water (and/or backwash water) to a street or storm drain. Call the County at 499-6528 for a copy of "Here's What To Do with the Water" or look in "other businesses" under www.mcstoppp.org

VEHICLE & EQUIPMENT

MAINTENANCE

- ▶ Frequently, inspect vehicles and equipment for leaks. Use drip pans to catch leaks until repairs are made; repair leaks promptly.
- ▶ Fuel and maintain vehicles on site only in a bermed area or over a drip pan that is big enough to prevent runoff.
- ▶ If you must clean vehicles or equipment on site, clean with water only - and in a bermed area that will not allow rinsewater to run into streets, stormdrains, ditches, or creeks.
- ▶ Do not clean vehicles or equipment on site using soaps, solvents, degreasers, steam cleaning equipment, etc.

SAW CUTTING

- ▶ Always completely cover or barricade storm drain inlets when saw cutting. Use filter fabric, sand bags, or fine gravel dams to keep slurry out of the storm drain system. If saw-cut slurry enters a stormdrain, clean up immediately.
- ▶ Shovel, absorb, or vacuum saw-cut slurry and pick up all waste as soon as you are finished in one location and by the end of each work day.

STORMWATER COORDINATORS (During Normal Business Hours)

Town of San Anselmo
Rabi Elias/Dave Craig
258-4616

City of Sausalito
Engineering
289-4191

Town of Corte Madera
Kevin Kramer
927-5057

City of San Rafael
Richard Landis
485-3355

City of Belvedere
Scott Derdenger
435-3838

County of Marin
Howard Bunce
499-3748

Town of Ross
Rob Maccario
453-8287 ext. 163

Town of Tiburon
Matt Swalberg
435-7354

Town of Fairfax
Kathy Wilkie
453-0291

City of Larkspur
Mike Myers
927-5017

City of Novato
Dave Harlan
899-8246

City of Mill Valley
Jill Barnes
388-4033 ext. 116

To report illegal discharges to local waterways occurring after normal business hours, call 911; or, the County Sheriff's non-emergency line at 499-7233.

To report oil and chemical spills occurring in "open waters" or "on land" call 1-800-OILS911.

To report fish kills or poaching, call the California Department of Fish and Game at 1-888-334-2258.