

00 41 43 – BID FORMS

1.1 Bid.

Bids will be received at the City of Sausalito, 420 Litho Street, Sausalito, CA 94965, until 2 p.m. on Monday, July 22, 2024.

NAME OF BIDDER: Bruiman Landscape & construction Inc.

The undersigned hereby declare that we have carefully examined the location of the proposed Work, and have read and examined the Contract Documents, including all plans, specifications, and all addenda, if any for the following Project:

FERRY LANDSIDE IMPROVEMENT PROJECT

We hereby propose to furnish all labor, materials, equipment, tools, transportation, and services, and to discharge all duties and obligations necessary and required to perform and complete the Project, as described and in strict conformity with the Drawings, and these Specifications for TOTAL BID PRICE indicated herein.

The undersigned acknowledges receipt, understanding, and full consideration of the following addenda to the Contract Documents:

Addenda No. #1 7/3/24, #2 7/15/24, #3 7/18/24

1. Attached is the required Bid Guarantee in the amount of not less than 10% of the Total Bid Price. ✓
2. Attached is the completed Designation of Subcontractors form. ✓
3. Attached is the fully executed Noncollusion Declaration form. ✓
4. Attached is the completed Iran Contracting Act Certification form. ✓
5. Attached is the completed Fleet Compliance Certification form. ✓
6. Attached is the completed Public Works Contractor Registration Certification form. ✓
7. Attached is the completed Contractor's Certificate Regarding Workers' Compensation form. ✓
8. Attached is the completed Bidder Information and Experience form. ✓
9. Attached in the Davis-Bacon Act Wages document.
10. Attached is the Fair Employment Practices Certificate form.
11. Attached is the Disqualification Questionnaire form.
12. Attached is the Buy America Certificate form.
13. Attached is the Equal Opportunity Certification form.
14. Attached is the Disclosure of Lobbying Activities form.
15. Attached is the Bidder's Statement of Qualifications and Business References form.
16. Attached is the SBE Goal Declaration form.
17. Attached is the Small Business Enterprise Affidavit of Size form.
18. Attached is the Good Faith Efforts Documentation form.
19. Attached is the DBE/SBE Confirmation of Participation in Contract form.
20. Attached is the Final Report-Utilization of Disadvantaged Business Enterprises (DBE) and First-Tier Subcontractors form.
21. Attached is the Prime Contractor and Subcontractor/Subconsultant/Supplier Report form.
22. Attached is the Monthly SBE Trucking Verification form.

*Acknowledged*  

**QUESTION 2: When do you want to start construction on this project? Are you waiting until after the summer season?**

**Response to Question 2:**

The construction will begin in **FALL 2024**.

**END RESPONSE TO QUESTIONS**

**REVISION TO PROJECT DOCUMENTS**

**REVISION TO THE PROJECT SPECIFICATIONS**

**REMOVE in its entirety A. BID SCHEDULE FOR BASE BID, B. BID SCHEDULE FOR BID ALTERNATIVE 1: WIDENED CONCRETE SIDEWALK AT HUMBOLDT AVENUE, C. BID SCHEDULE FOR BID ALTERNATIVE 2: GRAVELPAVE ON TRACY WAY, D. BID SCHEDULE FOR BID ALTERNATIVE 3: REPLACE STANDARD BOLLARDS WITH LIGHTED BOLLARDS, and E. BID SCHEDULE FOR BID ALTERNATIVE 4: EXCLUDE IMPROVEMENTS AT TRACY WAY and replace with the sections below:**

**A. BID SCHEDULE FOR BASE BID**

NO.	ITEM DESCRIPTION	UNIT OF MEASURE	EST. QTY.	UNIT PRICE	ITEM COST
1.	MOBILIZATION, DEMOBILIZATION, AND FINAL CLEANUP	LS	1	65,000	65,000
2.	TEMPORARY TRAFFIC CONTROL	LS	1	12,000	12,000
3.	STORM WATER MANAGEMENT AND EROSION CONTROL	LS	1	10,000	10,000
4.	DEMOLITION	SF	23,750	10	237,500
5.	ASPHALT FULL DEPTH CONFORM	TON	180	300	54,000
6.	ASPHALT CONCRETE WALKWAY	TON	45	300	13,500 <sup>24</sup>
7.	TYPE "A" CURB & GUTTER	LF	650	80	52,000
8.	TYPE "E" CURB	LF	90	66	5,940
9.	PEDESTRIAN CONCRETE (EXPOSED AGGREGATE)	SF	13,985	25	349,625

2024 Ferry Landside Improvement Project  
Addendum No. 2

10.	CURB RAMP WITH DETECTABLE WARNING SURFACE (COLONIAL RED)	EA	8	2400	19200
11.	CAST IN PLACE DETECTABLE WARNING SURFACE (COLONIAL RED)	EA	5	400	2000
12.	VEHICULAR CONCRETE	SF	1,955	35	68425
13.	4-INCH THERMOPLASTIC STRIPING	LF	250	15	3750
14.	6-IN THERMOPLASTIC STRIPING	LF	340	9	3060
15.	CONTINENTAL CROSSWALK	SF	2,285	10	22850
16.	PAVEMENT MARKINGS	EA	15	450	6750
17.	STRIPING PARKING STALL NUMBER	EA	7	100	700
18.	REINSTALL EXISTING SIGN ON NEW POLE	EA	16	300	4800
19.	NEW SIGN ON NEW POLE	EA	10	860	8600
20.	SELF-SERVICE PAY STATION RELOCATION	EA	6	1500	9000
21.	FOUNTAIN RELOCATION	LS	1	8000	8000
22.	ACCESSIBLE DRINKING FOUNTAIN	LS	1	6000	6000
23.	TYPE "A" CATCH BASIN	EA	1	5000	5000
24.	TRENCH DRAIN	LS	1	5000	5000
25.	12-INCH STORM DRAIN (HDPE)	EA	1	1500	1500
26.	ADJUST UTILITY TO GRADE	EA	7	300	2100
27.	RESET NGS BENCHMARK	EA	1	12000	12000
28.	RESET SURVEY MONUMENT	EA	1	4000	4000
29.	BIORETENTION AREA	LS	1	26000	26000
30.	BOLLARDS	EA	16	2400	38400
31.	MISCELLANEOUS FURNISHINGS AND FENCING	LS	1	20,000	20,000
32.	IRRIGATION	LS	1	70,000	70,000
33.	PLANTING	LS	1	90,000	90,000
34.	ELECTRICAL MANHOLE	EA	1	80,000	80,000

2024 Ferry Landside Improvement Project  
Addendum No. 2

TOTAL BID PRICE BASED ON BID SCHEDULE TOTAL OF UNIT PRICES  
FOR BASE BID

\$ 1,316,700<sup>00</sup>  
Total Bid Price in Numbers

one million three hundred sixteen thousand seven hundred  
Total Bid Price in Written Form

In case of discrepancy between the written price and the numerical price, the written price shall prevail.

**B. BID SCHEDULE FOR BID ALTERNATIVE 1: WIDENED CONCRETE SIDEWALK AT HUMBOLDT AVENUE**

NO.	ITEM DESCRIPTION	UNIT OF MEASURE	EST. QTY.	UNIT PRICE	ITEM COST
1.	DEMOLITION	SF	3,895	8	31600
2.	ASPHALT FULL DEPTH CONFORM	TON	40	550	22000
3.	ASPHALT CONCRETE WALKWAY (DEDUCT)	TON	45	-300	-13500
4.	TYPE "A" CURB & GUTTER	LF	240	100	24000
5.	PEDESTRIAN CONCRETE (EXPOSED AGGREGATE)	SF	3,100	25	77500
6.	CURB RAMP WITH DETECTABLE WARNING SURFACE (COLONIAL RED)	EA	2	2400	4800
7.	ADJUST UTILITY TO GRADE	EA	2	300	600
8.	REINSTALL EXISTING SIGN ON NEW POLE	EA	2	400	800

TOTAL BID PRICE BASED ON BID SCHEDULE TOTAL OF UNIT PRICES  
FOR BID ALTERNATIVE 1

\$ 147,360<sup>00</sup>  
Total Bid Price in Numbers

one hundred forty seven thousand three hundred sixty dollars  
Total Bid Price in Written Form

In case of discrepancy between the written price and the numerical price, the written price shall prevail.



2024 Ferry Landside Improvement Project  
Addendum No. 2

C. BID SCHEDULE FOR BID ALTERNATIVE 2: GRAVELPAVE ON TRACY WAY

NO.	ITEM DESCRIPTION	UNIT OF MEASURE	EST. QTY.	UNIT PRICE	ITEM COST
1.	ASPHALT GRINDING	SF	5,100	3	15300
2.	PLACE AND COMPACT ASPHALT GRINDING	SF	5,100	150	7650
3.	GRAVELPAVE - TYPE 2	SF	5,100	80	40800
4.	GRAVEL FILL	CY	15	15480 750	11250
5.	PEDESTRIAL CONCRETE (EXPLOSED AGGREGATE)	SF	150	25	3750

TOTAL BID PRICE BASED ON BID SCHEDULE TOTAL OF UNIT PRICES  
FOR BID ALTERNATIVE 2

\$ 78,750<sup>00</sup>  
Total Bid Price in Numbers

\$ seventy eight thousand seven hundred fifty dollars  
Total Bid Price in Written Form

In case of discrepancy between the written price and the numerical price, the written price shall prevail.

D. BID SCHEDULE FOR BID ALTERNATIVE 3: REPLACE STANDARD BOLLARDS WITH LIGHTED BOLLARDS

NO.	ITEM DESCRIPTION	UNIT OF MEASURE	EST. QTY.	UNIT PRICE	ITEM COST
1.	LIGHTED BOLLARDS	EA	16	3700	59200
2.	BOLLARDS (DEDUCT)	EA	16	-2400	-38400

TOTAL BID PRICE BASED ON BID SCHEDULE TOTAL OF UNIT PRICES  
FOR BID ALTERNATIVE 3

\$ ~~20,800~~ 20,800<sup>00</sup>  
Total Bid Price in Numbers

\$ twenty thousand eight hundred dollars  
Total Bid Price in Written Form

In case of discrepancy between the written price and the numerical price, the written price shall prevail.

2024 Ferry Landside Improvement Project  
Addendum No. 2

**E. BID SCHEDULE FOR BID ALTERNATIVE 4: EXCLUDE IMPROVEMENTS AT TRACY WAY**

NO.	ITEM DESCRIPTION	UNIT OF MEASURE	EST. QTY.	UNIT PRICE	ITEM COST
1.	DEMOLITION (DEDUCT)	SF	3,500	-6	-21000
2.	ASPHALT FULL DEPTH CONFORM (DEDUCT)	TON	20	-540	-10800
3.	TYPE "A" CURB & GUTTER (DEDUCT)	LF	110	-80	-8800
4.	TYPE "E" CURB (DEDUCT)	LF	90	-60	-5400
5.	PEDESTRIAN CONCRETE (EXPOSED AGGREGATE) (DEDUCT)	SF	2,330	-25	-58250
6.	CURB RAMP WITH DETECTABLE WARNING SURFACE (COLONIAL RED) (DEDUCT)	EA	2	-2400	-4800
7.	CAST IN PLACE DETECTABLE WARNING SURFACE (COLONIAL RED) (DEDUCT)	EA	1	-800	-800
8.	ADJUST UTILITY TO GRADE (DEDUCT)	EA	1	-300	-300
9.	NEW SIGN ON NEW POLE (DEDUCT)	EA	2	-400	-800

TOTAL BID PRICE BASED ON BID SCHEDULE TOTAL OF UNIT PRICES FOR BID ALTERNATIVE 4	
<del>92000</del> < 110,950 >	
Total Bid Price in Numbers	
\$ MINUS ONE HUNDRED TEN THOUSAND NINE HUNDRED FIFTY DOLLARS	
Total Bid Price in Written Form	
In case of discrepancy between the written price and the numerical price, the written price shall prevail.	

The costs for any Work shown or required in the Contract Documents, but not specifically identified as a line item are to be included in the related line items and no additional compensation shall be due to Contractor for the performance of the Work.

In case of discrepancy between the Unit Price and the Item Cost set forth for a unit basis item, the unit price shall prevail and shall be utilized as the basis for determining the lowest responsive, responsible Bidder. However, if the amount set forth as a unit price is ambiguous,

ALTERNATE BIDS	BID PRICE (IN WRITTEN FORM)	BID PRICE (IN NUMBERS)
<b>ALTERNATE #1</b> <b>WIDENED CONCRETE</b> <b>SIDEWALK AT HUMBOLDT</b> <b>AVENUE</b> <input checked="" type="checkbox"/> Add <input type="checkbox"/> Deduct		147,360 <sup>00</sup>
<b>ALTERNATE #2</b> <b>GRAVELPAVE ON TRACY</b> <b>WAY</b> <input checked="" type="checkbox"/> Add <input type="checkbox"/> Deduct		28,750 <sup>00</sup>
<b>ALTERNATE #3</b> <b>REPLACE STANDARD</b> <b>BOLLARDS WITH LIGHTED</b> <b>BOLLARDS</b> <input checked="" type="checkbox"/> Add <input type="checkbox"/> Deduct		20,800
<b>ALTERNATE #4</b> <b>EXCLUDE IMPROVEMENTS</b> <b>AT TRACY WAY</b> <input type="checkbox"/> Add <input checked="" type="checkbox"/> Deduct		110,950

The successful bidder hereby agrees to sign the contract and furnish the necessary bonds and certificates of insurance within ten (10) working days after the City provides the successful bidder with the Notice of Award.

Upon receipt of the signed contract and other required documents, the contract will be executed by the City, after which the City will prepare a letter giving Contractor Notice to Proceed. The official starting date shall be the date of the Notice to Proceed, unless otherwise specified. The undersigned agrees to begin the Work within ten (10) working days of the date of the Notice to Proceed, unless otherwise specified.

The undersigned has examined the location of the proposed work and is familiar with the Drawings and Specifications and the local conditions at the place where work is to be done.

If awarded the contract, the undersigned agrees that there shall be paid by the undersigned and by all subcontractors to all laborers, workers and mechanics employed in the execution of such contract no less than the prevailing wage rate within Marin County for each craft, classification, or type of worker needed to complete the Work contemplated by this contract as established by the Director of the Department of Industrial Relations. A copy of the prevailing rate of per diem wages are on file at the City's Administration Office and shall be made available to interested parties upon request.

Enclosed find cash, bidder's bond, or cashier's or certified check No. \_\_\_\_\_ from the \_\_\_\_\_ Bank in the amount of \_\_\_\_\_, which is not less than ten percent (10%) of this bid, payable to City of Sausalito as bid security and which is

The costs for any Work shown or required in the Contract Documents, but not specifically identified as a line item are to be included in the related line items and no additional compensation shall be due to Contractor for the performance of the Work.

In case of discrepancy between the Unit Price and the Item Cost set forth for a unit basis item, the unit price shall prevail and shall be utilized as the basis for determining the lowest responsive, responsible Bidder. However, if the amount set forth as a unit price is ambiguous, unintelligible or uncertain for any cause, or is omitted, or is the same amount as the entry in the "Item Cost" column, then the amount set forth in the "Item Cost" column for the item shall prevail and shall be divided by the estimated quantity for the item and the price thus obtained shall be the Unit Price.

For purposes of evaluating Bids, the City will correct any apparent errors in the extension of unit prices and any apparent errors in the addition of lump sum and extended prices.

The estimated quantities for Unit Price items are for purposes of comparing Bids only and the City makes no representation that the actual quantities of work performed will not vary from the estimates. Final payment shall be determined by the Engineer from measured quantities of work performed based upon the Unit Price.

**F. TOTAL BID PRICE:**

TOTAL BID PRICE BASED ON BID SCHEDULE TOTAL OF UNIT PRICES FOR FERRY LANDSIDE IMPROVEMENT PROJECT	
\$ 1,452,662 <sup>00</sup>	Total Bid Price in Numbers
\$ one million, four hundred & fifty two thousand, six hundred & sixty dollars 00/100	Total Bid Price in Written Form
In case of discrepancy between the written price and the numerical price, the written price shall prevail.	

The undersigned agrees that this Bid Form constitutes a firm offer to the City which cannot be withdrawn for the number of calendar days indicated in the Notice Inviting Bids from and after the Bid opening, or until a Contract for the Work is fully executed by the City and a third party, whichever is earlier.

If the Contract Documents specify Alternate Bid items, the following Alternate Bid amounts shall be added to or deducted from the Total Bid Price entered above (please check the appropriate box), in the City's sole discretion. The City can choose to include any, all, or none of the Alternate Bid items in the Work. If the City selects any of the Alternate Bid items, the corresponding Alternate Bid prices shall be added to or deducted from Base Bid Price for the Work. The City can award/select Alternate Bid items at any time(s).

given as a guarantee that the undersigned will enter into a contract and provide the necessary bonds and certificates of insurance if awarded the Work.

The bidder furthermore agrees that in case of bidder's default in executing said contract and furnishing required bonds and certificates of insurance, the cash, bidder's bond, or cashier's or certified check accompanying this proposal and the money payable thereon shall become and shall remain the property of the City of Sausalito.

Bidder is an individual \_\_\_\_\_, or corporation X, or partnership \_\_\_\_\_, organized under the laws of the State of California.

Bidder confirms license(s) required by California State Contractor's License Law for the performance of the subject project are in full effect and proper order. The following are the Bidder's applicable license number(s), with their expiration date(s) and class of license(s):

372498 A, C-27 6/30/2025  
\_\_\_\_\_  
\_\_\_\_\_

If the Bidder is a joint venture, each member of the joint venture must include the required licensing information.

Sureties that will furnish the Faithful Performance Bond and the Labor and Material Payment Bond, in the form specified herein, in an amount equal to one hundred percent (100%) of the contract price within ten (10) working days from the date the City provides the successful bidder the Notice of Award. Sureties must meet all of the State of California bonding requirements, as defined in California Code of Civil Procedure Section 995.120 and must be authorized by the State of California.

The insurance company or companies to provide the insurance required in the contract documents must have a Financial Strength Rating of not less than "A-" and a Financial Size Category of not less than "Class VII" according to the latest Best Key Rating Guide. At the sole discretion of the City, the City may waive the Financial Strength Rating and the Financial Size Category classifications for Workers' Compensation insurance.

(signatures continued on next page)

I hereby certify under penalty of perjury under the laws of the State of California that all of the information submitted in connection with this Bid and all of the representations made herein are true and correct.

Executed at San Rafael, on this 22 day of July <sup>AB</sup> 2024

(Bidders Name – Print or Type)

Bauman Landscape & construction Inc  
(Name and Title)

(Corporate Seal)

Angela M. Bauman, corp secretary  
(Signature)

Names of individual members of firm or names and titles of all officers of corporation and their addresses are listed below:

Name Mike Bauman Title President

Complete Address 20 Maniton dr. San Anselmo CA 94960

Phone 415 447 4000 FAX estimating@baumanland.com

Name Angela Bauman Title corp secretary

Complete Address 40 Tamy Rd. San Anselmo CA 94960

Phone 415 447 4000 FAX estimating@baumanland.com

Name Ellie T. Bauman Title Chairman

Complete Address 20 Maniton dr., San Anselmo CA 94960

Phone 415 454 9038 FAX N/A

Name \_\_\_\_\_ Title \_\_\_\_\_

Complete Address \_\_\_\_\_

Phone \_\_\_\_\_ FAX \_\_\_\_\_

1.2 Bid Bond

[Note: Not required when other form of Bidder's Security, e.g. cash, certified check or cashier's check, accompanies bid.]

The makers of this bond are, Bauman Landscape and Construction, Inc., as Principal, and Philadelphia Indemnity Insurance Company, as Surety and are held and firmly bound unto the City of Sausalito, hereinafter called the City, in the penal sum of TEN PERCENT (10%) OF THE TOTAL BID PRICE of the Principal submitted to City for the work described below, for the payment of which sum in lawful money of the United States, well and truly to be made, we bind ourselves, our heirs, executors, administrators, successors and assigns, jointly and severally, firmly by these presents.

THE CONDITION OF THIS OBLIGATION IS SUCH that whereas the Principal has submitted the accompanying bid dated July 22, 2024, for Ferry Landside Improvement Project.

If the Principal does not withdraw its Bid within the time specified in the Contract Documents; and if the Principal is awarded the Contract and provides all documents to the City as required by the Contract Documents; then this obligation shall be null and void. Otherwise, this bond will remain in full force and effect.

Surety, for value received, hereby stipulates and agrees that no change, extension of time, alteration or addition to the terms of the Contract Documents shall in affect its obligation under this bond, and Surety does hereby waive notice of any such changes.

In the event a lawsuit is brought upon this bond by the City and judgment is recovered, the Surety shall pay all litigation expenses incurred by the City in such suit, including reasonable attorneys' fees, court costs, expert witness fees and expenses.

By their signatures hereunder, Surety and Principal hereby confirm under penalty of perjury that surety is an admitted surety insurer authorized to do business in the State of California.

IN WITNESS WHEREOF, the above-bound parties have executed this instrument under their several seals this 19th day of July, 2024, the name and corporate seal of each corporation.

(Corporate Seal)

Bauman Landscape and Construction, Inc.  
Contractor/ Principal

By [Signature]  
Title Corp. secretary

(Corporate Seal)

Philadelphia Indemnity Insurance Company  
Surety

By [Signature]  
Attorney-in-Fact

(Attach Attorney-in-Fact Certificate)

Title K. Zerounian, Attorney-In-Fact

## Notary Acknowledgment

A notary public or other officer completing this certificate verifies only the identity of the individual who signed the document to which this certificate is attached, and not the truthfulness, accuracy, or validity of that document.

STATE OF CALIFORNIA  
 COUNTY OF Marin

On July 22<sup>nd</sup>, 2024, before me, Patrick Laake, Notary Public, personally appeared Angela Dauman, who proved to me on the basis of satisfactory

Name(s) of Signer(s)  
 evidence to be the person(s) whose name(s) is/are subscribed to the within instrument and acknowledged to me that he/she/they executed the same in his/her/their authorized capacity(ies), and that by his/her/their signature(s) on the instrument the person(s), or the entity upon behalf of which the person(s) acted, executed the instrument.

I certify under PENALTY OF PERJURY under the laws of the State of California that the foregoing paragraph is true and correct.

WITNESS my hand and official seal.

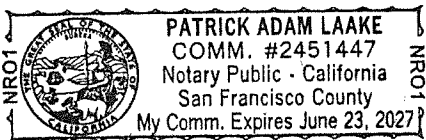

Patrick Laake  
 Signature of Notary Public

### OPTIONAL

*Though the information below is not required by law, it may prove valuable to persons relying on the document and could prevent fraudulent removal and reattachment of this form to another document.*

#### CAPACITY CLAIMED BY SIGNER

- Individual
  - Corporate Officer  
Vice President, corp. secretary  
Title(s)
  - Partner(s)                       Limited  
     General
  - Attorney-In-Fact
  - Trustee(s)
  - Guardian/Conservator
  - Other:
- Signer is representing:  
 Name Of Person(s) Or Entity(ies)

#### DESCRIPTION OF ATTACHED DOCUMENT

BID BOND  
Title or Type of Document

---

Number of Pages

---

Date of Document

---

Signer(s) Other Than Named Above

NOTE: This acknowledgment is to be completed for Contractor/Principal.





# ACKNOWLEDGMENT

A notary public or other officer completing this certificate verifies only the identity of the individual who signed the document to which this certificate is attached, and not the truthfulness, accuracy, or validity of that document.

State of California  
County of San Francisco )

On JULY 19, 2024 before me, M. Moody, Notary Public  
(insert name and title of the officer)

personally appeared K. Zerounian  
who proved to me on the basis of satisfactory evidence to be the person(s) whose name(s) is/are subscribed to the within instrument and acknowledged to me that he/she/they executed the same in his/her/their authorized capacity(ies), and that by his/her/their signature(s) on the instrument the person(s), or the entity upon behalf of which the person(s) acted, executed the instrument.

I certify under PENALTY OF PERJURY under the laws of the State of California that the foregoing paragraph is true and correct.

WITNESS my hand and official seal.

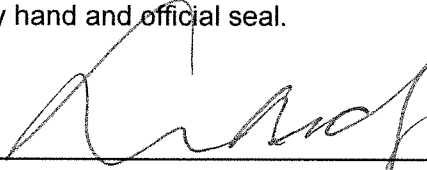
Signature  (Seal)

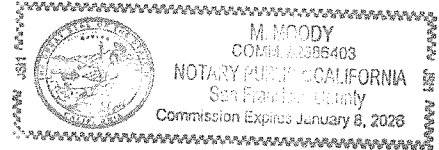

PHILADELPHIA INDEMNITY INSURANCE COMPANY

One Bala Plaza, Suite 100  
Bala Cynwyd, PA 19004-0950

Power of Attorney

KNOW ALL PERSONS BY THESE PRESENTS: That PHILADELPHIA INDEMNITY INSURANCE COMPANY (the Company), a corporation organized and existing under the laws of the Commonwealth of Pennsylvania, does hereby constitute and appoint **Maureen O'Connell, Kevin Re, Robert Wrixon, M. Moody, Susan M. Exline, Janet C. Rojo, Betty L. Tolentino, Susan Hecker, Virginia L. Black, Julia Ortega, Thuyduong Le, Brittany Kavan, K. Zerounian, Misty R. Hemje, Courtney Chew, and Maria De Los Angeles Reynoso of Arthur J. Gallagher Risk Management Services, LLC.** its true and lawful Attorney-in-fact with full authority to execute on its behalf bonds, undertakings, recognizances and other contracts of indemnity and writings obligatory in the nature thereof issued in the course of its business and to bind the Company thereby, in an amount not to exceed \$50,000,000.

This Power of Attorney is granted and is signed and sealed by facsimile under and by the authority of the following Resolution adopted by the Board of Directors of PHILADELPHIA INDEMNITY INSURANCE COMPANY on the 14<sup>th</sup> of November, 2016.

**RESOLVED:** That the Board of Directors hereby authorizes the President or any Vice President of the Company: (1) Appoint Attorney(s) in Fact and authorize the Attorney(s) in Fact to execute on behalf of the Company bonds and undertakings, contracts of indemnity and other writings obligatory in the nature thereof and to attach the seal of the Company thereto; and (2) to remove, at any time, any such Attorney-in-Fact and revoke the authority given. And, be it

**FURTHER RESOLVED:** That the signatures of such officers and the seal of the Company may be affixed to any such Power of Attorney or certificate relating thereto by facsimile, and any such Power of Attorney so executed and certified by facsimile signatures and facsimile seal shall be valid and binding upon the Company in the future with respect to any bond or undertaking to which it is attached.

IN TESTIMONY WHEREOF, PHILADELPHIA INDEMNITY INSURANCE COMPANY HAS CAUSED THIS INSTRUMENT TO BE SIGNED AND ITS CORPORATE SEAL TO BE AFFIXED BY ITS AUTHORIZED OFFICE THIS 5<sup>TH</sup> DAY OF MARCH, 2021.

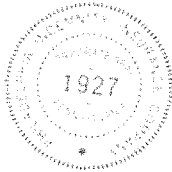

(Seal)

John Glomb, President & CEO  
Philadelphia Indemnity Insurance Company

On this 5<sup>th</sup> day of March, 2021 before me came the individual who executed the preceding instrument, to me personally known, and being by me duly sworn said that he is the therein described and authorized officer of the PHILADELPHIA INDEMNITY INSURANCE COMPANY; that the seal affixed to said instrument is the Corporate seal of said Company; that the said Corporate Seal and his signature were duly affixed.

Notary Public:

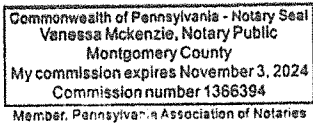

residing at:

Bala Cynwyd, PA

My commission expires:

November 3, 2024

I, Edward Sayago, Corporate Secretary of PHILADELPHIA INDEMNITY INSURANCE COMPANY, do hereby certify that the foregoing resolution of the Board of Directors and the Power of Attorney issued pursuant thereto on the 5<sup>th</sup> day March, 2021 are true and correct and are still in full force and effect. I do further certify that John Glomb, who executed the Power of Attorney as President, was on the date of execution of the attached Power of Attorney the duly elected President of PHILADELPHIA INDEMNITY INSURANCE COMPANY.

In Testimony Whereof I have subscribed my name and affixed the facsimile seal of each Company this 19<sup>th</sup> day of July, 2024.



Edward Sayago, Corporate Secretary  
PHILADELPHIA INDEMNITY INSURANCE COMPANY

1.3 List of Subcontractors

In compliance with the Subletting and Subcontracting Fair Practices Act Chapter 4 (commencing at Section 4100), Part 1, Division 2 of the Public Contract Code of the State of California and any amendments thereof, Bidder shall set forth below: (a) the name and the location of the place of business, (b) the California contractor license number, (c) the DIR public works contractor registration number unless exempt pursuant to Labor Code Sections 1725.5 and 1771.1, and (d) the portion of the work which will be done by each subcontractor who will perform work or labor or render service to the Bidder in or about the construction of the work or improvement to be performed under this Contract in an amount in excess of one-half of one percent (0.5%) of the Bidder's Total Bid Price. Notwithstanding the foregoing, if the work involves the construction of streets and highways, then the Bidder shall list each subcontractor who will perform work or labor or render service to the Bidder in or about the work in an amount in excess of one-half of one percent (0.5%) of the Bidder's Total Bid Price or \$10,000, whichever is greater. No additional time shall be granted to provide the below requested information.

If a Bidder fails to specify a subcontractor or if a contractor specifies more than one subcontractor for the same portion of work, then the Bidder shall be deemed to have agreed that it is fully qualified to perform that portion of work and that it shall perform that portion itself.

Work to be done by Subcontractor	Name of Subcontractor	Location of Business	CSLB Contractor License No.	DIR Registration Number	% of Work
Electrical	CT Electraz	Castro Valley CA	1035094	PW LR 1000754	10 136
stripping	stripping graphics	cotati CA	576 4756	100000 6495	5

Work to be done by Subcontractor	Name of Subcontractor	Location of Business	CSLB Contractor License No.	DIR Registration Number	% of Work

(Attach additional sheets if necessary)

Name of Bidder Bauman Landscape & construction Inc.

Signature 

Name and Title Angela M. Bauman, corporate secretary

Dated 1/22/24

1.4 Bidder Information and Experience Form

ARTICLE 1. INFORMATION ABOUT BIDDER

(Indicate not applicable ("N/A") where appropriate.)

NOTE: Where Bidder is a joint venture, pages shall be duplicated and information provided for all parties to the joint venture.

- 1.0 Name of Bidder: Bauman Landscape & construction
- 2.0 Type, if Entity: Corporation INC.
- 3.0 Bidder Address: 2920 Lyon St. San Francisco  
CA 94123
- estimating@baumanland.com 415 447 4808  
Facsimile Number Telephone Number
- \_\_\_\_\_  
Email Address
- 4.0 How many years has Bidder's organization been in business as a Contractor?  
45
- 5.0 How many years has Bidder's organization been in business under its present name?  
20
- 5.1 Under what other or former names has Bidder's organization operated?  
Bauman Landscape Inc.
- 6.0 If Bidder's organization is a corporation, answer the following:
- 6.1 Date of Incorporation: ~~7/22/2014~~ AB. 04/09/2019
- 6.2 State of Incorporation: CA
- 6.3 President's Name: Michael P. Bauman,
- 6.4 Vice-President's Name(s): Angela Bauman
- \_\_\_\_\_  
6.5 Secretary's Name: Angela Bauman
- 6.6 Treasurer's Name: Elise T. Bauman  
Chairman

7.0 If an individual or a partnership, answer the following:

7.1 Date of Organization: N/A

7.2 Name and address of all partners (state whether general or limited partnership):

\_\_\_\_\_  
\_\_\_\_\_  
\_\_\_\_\_

8.0 If other than a corporation or partnership, describe organization and name principals:

N/A  
\_\_\_\_\_  
\_\_\_\_\_

9.0 List other states in which Bidder's organization is legally qualified to do business.

NONE  
\_\_\_\_\_  
\_\_\_\_\_

10.0 What type of work does the Bidder normally perform with its own forces?

sitework - All but Electrical & Fencing  
\_\_\_\_\_  
\_\_\_\_\_

11.0 Has Bidder ever failed to complete any work awarded to it? If so, note when, where, and why:

NO  
\_\_\_\_\_  
\_\_\_\_\_

12.0 Within the last five years, has any officer or partner of Bidder's organization ever been an officer or partner of another organization when it failed to complete a contract? If so, attach a separate sheet of explanation:

NO  
\_\_\_\_\_  
\_\_\_\_\_

13.0 List Trade References:

Cemex - Melissa Miranda Phone: 713-401-6175  
vulcan - Ashlyn Bitonio Phone: 341-786-2934  
SITONE - Briana Decarmo Phone: 770-687-4076  
GoldenState Lumber - Tianne Cook Phone: 415-444-9186

14.0 List Bank References (Bank and Branch Address):

Sergey Shikhvarg 415 769 7759  
FIVE STAR BANK, SF Branch  
2240 Douglas Blvd. Suite 100 Roseville  
CA 95661

15.0 Name of Bonding Company and Name and Address of Agent:

AJ Gallagher - Jackie Robinson 415 546 9300  
595 Market St. #2100 SF 94105

[REMAINDER OF THIS PAGE INTENTIONALLY LEFT BLANK]





**ARTICLE 3. LIST OF COMPLETED PROJECTS – LAST THREE YEARS**

[\*\*Duplicate Page if needed for listing additional completed projects.\*\*]

Please include only those projects which are similar enough to demonstrate Bidder's ability to perform the required Work.

Project	Description of Bidder's Work	Completion Date	Cost of Bidder's Work
Vanness corridor	Pavers, landscape, concrete		\$33M
See attached			

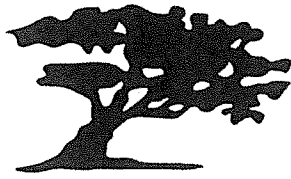

**BAUMAN**  
LANDSCAPE CONSTRUCTION  
GENERAL SITEWORK

**Bidder's Questionnaire**

**1. Project Name: Chestnut Streetscape**

Location: San Francisco, CA

Project Description: Streetscape

Owner: San Francisco Public Works

Prime GC: Bauman Landscape and Construction, Inc.

Architect/Engineer: SF Public Works Design & Engineering

Project Manager: Angela Bauman, [angela@baumanland.com](mailto:angela@baumanland.com), 415-447-4800

Work Performed: Paving, Underground utilities, electrical, sewer, etc.

Start Date: 6/2017    Planned Completion Date: 12/2018    Actual Comp. Date: 12/2018

Contract Amount: \$4,625,122.00    Change Order Amount: \$465,380.00

Time Extensions: N/A

Stop Notices: N/A

Liquidated Damages: \$0

Claims: N/A

**2. Project Name: Van Ness Corridor**

Location: San Fransico, CA

Project Description: Streetscape

Owner: San Francisco Municipal Transportation Agency

Prime GC: Walsh Construction Company

Architect/Engineer: N/A

Project Manager: Angela Bauman, [angela@baumanland.com](mailto:angela@baumanland.com), 415-447-4800

Work Performed: Pavers, Landscaping, irrigation, concrete, etc.

Start Date: 2018      Planned Completion Date: 2020      Actual Comp. Date: 2021

Contract Amount: \$33,000,000.00                      Change Order Amount: Included

Time Extensions: N/A

Stop Notices: N/A

Liquidated Damages: \$0

Claims: N/A

**3. Project Name: Various Locations No. 50**

Location: San Fransico, CA

Project Description: Streetscape

Owner: San Francisco Public Works

Prime GC: Bauman Landscape and Construction, Inc.

Architect/Engineer: SF Public Works Bureau of Engineering

Project Manager: Angela Bauman, [angela@baumanland.com](mailto:angela@baumanland.com), 415-447-4800

Work Performed: Concrete, AC Pave, Sewer, etc.

Start Date: 2022      Planned Completion Date: 2023      Actual Comp. Date: 2023

Contract Amount: \$2,300,000.00      Change Order Amount: Included

Time Extensions: N/A

Stop Notices: N/A

Liquidated Damages: \$0

Claims: N/A

#### **4. Project Name: 22<sup>nd</sup> Green Connection**

Location: San Francisco, CA

Project Description: Streetscape

Owner: San Francisco Public Works

Prime GC: Bauman Landscape and Construction, Inc.

Architect/Engineer: SF Public Works Design & Engineering

Project Manager: Angela Bauman, [angela@baumanland.com](mailto:angela@baumanland.com), 415-447-4800

Work Performed: Paving, Underground utilities, electrical, sewer, etc.

Start Date: 2018      Planned Completion Date: 2020      Actual Comp. Date: 2020

Contract Amount: \$3,316,348.00      Change Order Amount: Included

Time Extensions: N/A

Stop Notices: N/A

Liquidated Damages: \$0

Claims: N/A

**5. Project Name: Veteran's Memorial Parking Lot**

Location: San Rafael, CA

Project Description: Parking Lot at Civic Center – San Rafael

Owner: County of Marin

Prime GC: Bauman Landscape and Construction, Inc.

Architect/Engineer: BKF Engineers

Project Manager: Angela Bauman, [angela@baumanland.com](mailto:angela@baumanland.com), 415-447-4800

Work Performed: new parking lot, Subgrade repairs, new drainage system, irrigation, landscaping

Start Date: 10/2023      Planned Completion Date: 06/2024      Actual Comp. Date: 06/2024

Contract Amount: \$7,000,000.00

Change Order Amount: \$500,000.00

Time Extensions: N/A

Stop Notices: N/A

Liquidated Damages: \$0

Claims: N/A

**6. Project Name: Maxwell Farms Regional Park**

Location: Sonoma, CA

Project Description: Park Renovation

Owner: County of Sonoma

Prime GC: Bauman Landscape and Construction, Inc.

Architect/Engineer: BKF Engineers

Project Manager: Angela Bauman, [angela@baumanland.com](mailto:angela@baumanland.com), 415-447-4800

Work Performed: Improv. To Existing park Facilities including parking area w/lighting, synthetic turf baseball field, new pathways, site furnishings, landscape planting and irrigation and utility improvements.

Start Date: 2022          Planned Completion Date: 2023          Actual Comp. Date: 2023

Contract Amount: \$7,300,000.00                                  Change Order Amount: Included

Time Extensions: N/A

Stop Notices: N/A

Liquidated Damages: \$0

Claims: N/A



## **5.2 Three largest completed projects within the last three years:**

### **1. Project Name: Van Ness Corridor**

Location: San Francisco, CA

Project Description: Streetscape

Owner: San Francisco Municipal Transportation Agency

Prime GC: Walsh Construction Company

Architect/Engineer: N/A

Project Manager: Angela Bauman, [angela@baumanland.com](mailto:angela@baumanland.com), 415-447-4800

Work Performed: Pavers, Landscaping, irrigation, concrete, etc.

Start Date: 2018      Planned Completion Date: 2020      Actual Comp. Date: 2021

Contract Amount: \$33,000,000.00      Change Order Amount: Included

Time Extensions: N/A

Stop Notices: N/A

Liquidated Damages: \$0

Claims: N/A

**2. Project Name: Veteran's Memorial Parking Lot**

Location: San Rafael, CA

Project Description: Parking Lot at Civic Center – San Rafael

Owner: County of Marin

Prime GC: Bauman Landscape and Construction, Inc.

Architect/Engineer: BKF Engineers

Project Manager: Angela Bauman, [angela@baumanland.com](mailto:angela@baumanland.com), 415-447-4800

Work Performed: new parking lot, Subgrade repairs, new drainage system, irrigation, landscaping

Start Date: 10/2023      Planned Completion Date: 06/2024      Actual Comp. Date: 06/2024

Contract Amount: \$7,000,000.00

Change Order Amount: \$500,000.00

Time Extensions: N/A

Stop Notices: N/A

Liquidated Damages: \$0

Claims: N/A

### 3. Project Name: Maxwell Farms Regional Park

Location: Sonoma, CA

Project Description: Park Renovation

Owner: County of Sonoma

Prime GC: Bauman Landscape and Construction, Inc.

Architect/Engineer: BKF Engineers

Project Manager: Angela Bauman, [angela@baumanland.com](mailto:angela@baumanland.com), 415-447-4800

Work Performed: Improv. To Existing park Facilities including parking area w/lighting, synthetic turf baseball field, new pathways, site furnishings, landscape planting and irrigation and utility improvements.

Start Date: 2022          Planned Completion Date: 2023          Actual Comp. Date: 2023

Contract Amount: \$7,300,000.00          Change Order Amount: Included

Time Extensions: N/A

Stop Notices: N/A

Liquidated Damages: \$0

Claims: N/A

**5.3 Any project which is similar to this project including scope and character of the work:**

**Project Name: Maxwell Farms Regional Park**

Location: Sonoma, CA

Project Description: Park Renovation

Owner: County of Sonoma

Prime GC: Bauman Landscape and Construction, Inc.

Architect/Engineer: BKF Engineers

Project Manager: Angela Bauman, [angela@baumanland.com](mailto:angela@baumanland.com), 415-447-4800

Work Performed: Improv. To Existing park Facilities including parking area w/lighting, synthetic turf baseball field, new pathways, site furnishings, landscape planting and irrigation and utility improvements.

Start Date: 2022          Planned Completion Date: 2023          Actual Comp. Date: 2023

Contract Amount: \$7,300,000.00                                  Change Order Amount: Included

Time Extensions: N/A

Stop Notices: N/A

Liquidated Damages: \$0

Claims: N/A

**ARTICLE 4. EXPERIENCE AND TECHNICAL QUALIFICATIONS QUESTIONNAIRE**

**Personnel:**

The Bidder shall identify the key personnel to be assigned to this project in a management, construction supervision or engineering capacity.

1. List each person's job title, name and percent of time to be allocated to this project:

PM, Angela or Pedro 80  
Adam Stinson, Foreman 80-100  
or Ken Kelly, super 10-20  
grading Foreman, 80-100

2. Summarize each person's specialized education:

Bachelor's degree  
years of experience

3. List each person's years of construction experience relevant to the project:

20+ years All

4. Summarize such experience:

All experience w/ Bauman

Bidder agrees that personnel named in this Bid will remain on this Project until completion of all relevant Work, unless substituted by personnel of equivalent experience and qualifications approved in advance by the City.

**Changes Occurring Since Prequalification**

If any substantive changes have occurred since Bidder submitted its prequalification package for this Project, Bidder shall list them below. If none are listed, Bidder certifies that no substantive changes have occurred.

\_\_\_\_\_  
\_\_\_\_\_  
\_\_\_\_\_  
\_\_\_\_\_  
\_\_\_\_\_

**Additional Bidder's Statements:**

If the Bidder feels that there is additional information which has not been included in the questionnaire above, and which would contribute to the qualification review, it may add that information in a statement here or on an attached sheet, appropriately marked:

---

---

---

---

---

---

**ARTICLE 5. VERIFICATION AND EXECUTION**

These Bid Forms shall be executed only by a duly authorized official of the Bidder:

I declare under penalty of perjury under the laws of the State of California that the foregoing information is true and correct:

Name of Bidder Bauman Landscape & construction Inc.

Signature 

Name Angela M. Bauman

Title V.P.

Date 7/22/2024

1.5 Non-Collusion Declaration

The undersigned declares:

I am the corp secretary of Bauman Landscaped Const Inc., the party making the foregoing Bid.

The Bid is not made in the interest of, or on behalf of, any undisclosed person, partnership, company, association, organization, or corporation. The Bid is genuine and not collusive or sham. The Bidder has not directly or indirectly induced or solicited any other Bidder to put in a false or sham bid. The Bidder has not directly or indirectly colluded, conspired, connived, or agreed with any Bidder or anyone else to put in a sham bid, or to refrain from bidding. The Bidder has not in any manner, directly or indirectly, sought by agreement, communication, or conference with anyone to fix the Bid Price of the Bidder or any other Bidder, or to fix any overhead, profit, or cost element of the Bid Price, or of that of any other Bidder. All statements contained in the Bid are true. The Bidder has not, directly or indirectly, submitted his or her Bid Price or any breakdown thereof, or the contents thereof, or divulged information or data relative thereto, to any corporation, partnership, company, association, organization, bid depository, or to any member or agent thereof to effectuate a collusive or sham bid, and has not paid, and will not pay, any person or entity for such purpose.

Any person executing this declaration on behalf of a Bidder that is a corporation, partnership, joint venture, limited liability company, limited liability partnership, or any other entity, hereby represents that he or she has full power to execute, and does execute, this declaration on behalf of the Bidder.

I declare under penalty of perjury under the laws of the State of California that the foregoing is true and correct and that this declaration is executed on 22 of July [date], at San Rafael [city], CA [state].

Name of Bidder Bauman Landscaped Const.  
Signature [Handwritten Signature]  
Name Angela M. Bauman  
Title Corp. Secretary

# CALIFORNIA ALL- PURPOSE CERTIFICATE OF ACKNOWLEDGMENT

A notary public or other officer completing this certificate verifies only the identity of the individual who signed the document to which this certificate is attached, and not the truthfulness, accuracy, or validity of that document.

State of California }

County of Marin }

On July 22<sup>nd</sup> 2024 before me, Patrick Laake Notary Public,  
(Here insert name and title of the officer)

personally appeared Angela Bauman,  
 who proved to me on the basis of satisfactory evidence to be the person(s) whose name(s) is/are subscribed to the within instrument and acknowledged to me that he/she/they executed the same in his/her/their authorized capacity(ies), and that by his/her/their signature(s) on the instrument the person(s), or the entity upon behalf of which the person(s) acted, executed the instrument.

I certify under PENALTY OF PERJURY under the laws of the State of California that the foregoing paragraph is true and correct.

WITNESS my hand and official seal.

Patrick Laake

Notary Public Signature

(Notary Public Seal)



## ADDITIONAL OPTIONAL INFORMATION

DESCRIPTION OF THE ATTACHED DOCUMENT

Ferry Landside Improvement  
(Title or description of attached document)

Project  
(Title or description of attached document continued)

Number of Pages \_\_\_\_\_ Document Date \_\_\_\_\_

CAPACITY CLAIMED BY THE SIGNER

Individual (s)

Corporate Officer  
via President  
(Title)

Partner(s)

Attorney-in-Fact

Trustee(s)

Other \_\_\_\_\_

## INSTRUCTIONS FOR COMPLETING THIS FORM

*This form complies with current California statutes regarding notary wording and, if needed, should be completed and attached to the document. Acknowledgments from other states may be completed for documents being sent to that state so long as the wording does not require the California notary to violate California notary law.*

- State and County information must be the State and County where the document signer(s) personally appeared before the notary public for acknowledgment.
- Date of notarization must be the date that the signer(s) personally appeared which must also be the same date the acknowledgment is completed.
- The notary public must print his or her name as it appears within his or her commission followed by a comma and then your title (notary public).
- Print the name(s) of document signer(s) who personally appear at the time of notarization.
- Indicate the correct singular or plural forms by crossing off incorrect forms (i.e. ~~he/she/they~~, is /are) or circling the correct forms. Failure to correctly indicate this information may lead to rejection of document recording.
- The notary seal impression must be clear and photographically reproducible. Impression must not cover text or lines. If seal impression smudges, re-seal if a sufficient area permits, otherwise complete a different acknowledgment form.
- Signature of the notary public must match the signature on file with the office of the county clerk.
  - ❖ Additional information is not required but could help to ensure this acknowledgment is not misused or attached to a different document.
  - ❖ Indicate title or type of attached document, number of pages and date.
  - ❖ Indicate the capacity claimed by the signer. If the claimed capacity is a corporate officer, indicate the title (i.e. CEO, CFO, Secretary).
- Securely attach this document to the signed document with a staple.



1.6 Iran Contracting Act Certification.  
(Public Contract Code section 2200 et seq.)

As required by California Public Contract Code Section 2204, the Contractor certifies subject to penalty for perjury that the option checked below relating to the Contractor's status in regard to the Iran Contracting Act of 2010 (Public Contract Code Section 2200 *et seq.*) is true and correct:

The Contractor is not:

- (1) identified on the current list of person and entities engaged in investment activities in Iran prepared by the California Department of General Services in accordance with subdivision (b) of Public Contract Code Section 2203; or
- (2) a financial instruction that extends, for 45 days or more, credit in the amount of \$20,000,000 or more to any other person or entity identified on the current list of persons and entities engaging in investment activities in Iran prepared by the California Department of General Services in accordance with subdivision (b) of Public Contract Code Section 2203, if that person or entity uses or will use the credit to provide goods or services in the energy sector in Iran.

The City has exempted the Contractor from the requirements of the Iran Contracting Act of 2010 after making a public finding that, absent the exemption, the City will be unable to obtain the goods and/or services to be provided pursuant to the Contract.

The amount of the Contract payable to the Contractor for the Project does not exceed \$1,000,000.

Signature: 

Printed Name: Angela M. Bauman

Title: VP

Firm Name: Bauman Landscaped & Const.

Date: 7/27/2024

Note: In accordance with Public Contract Code Section 2205, false certification of this form shall be reported to the California Attorney General and may result in civil penalties equal to the greater of \$250,000 or twice the Contract amount, termination of the Contract and/or ineligibility to bid on contracts for three years.

1.7 Fleet Compliance Certification

Bidder hereby acknowledges that they have reviewed the California Air Resources Board's policies, rules and regulations and are familiar with the requirements of Title 13, California Code of Regulations, Division 3, Chapter 9, effective on January 1, 2024 (the "Regulation"). Bidder hereby certifies, subject to penalty for perjury, that the option checked below relating to the Bidder's fleet, and/or that of their subcontractor(s) ("Fleet") is true and correct:

- The Fleet is subject to the requirements of the Regulation, and the appropriate Certificate(s) of Reported Compliance have been attached hereto.
- The Fleet is exempt from the Regulation under section 2449.1(f)(2), and a signed description of the subject vehicles, and reasoning for exemption has been attached hereto.
- Bidder and/or their subcontractor is unable to procure R99 or R100 renewable diesel fuel as defined in the Regulation pursuant to section 2449.1(f)(3). Bidder shall keep detailed records describing the normal refueling methods, their attempts to procure renewable diesel fuel and proof that shows they were not able to procure renewable diesel (i.e. third party correspondence or vendor bids).
- The Fleet is exempt from the requirements of the Regulation pursuant to section 2449(i)(4) because this Project has been deemed an Emergency, as defined under section 2449(c)(18). Bidder shall only operate the exempted vehicles in the emergency situation and records of the exempted vehicles must be maintained, pursuant to section 2449(i)(4).
- The Fleet does not fall under the Regulation or are otherwise exempted and a detailed reasoning is attached hereto.

Name of Bidder: Bauman Landscape & Construction Inc.

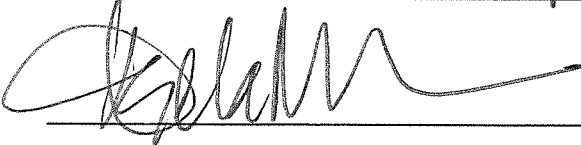
Signature: 

Name: Angela M. Bauman,

Title: Corp. Secretary

Date: 1/22/2024

1.8 Public Works Contractor Registration Certification

Pursuant to Labor Code sections 1725.5 and 1771.1, all contractors and subcontractors that wish to bid on, be listed in a bid proposal, or enter into a contract to perform public work must be registered with the Department of Industrial Relations. See <http://www.dir.ca.gov/Public-Works/PublicWorks.html> for additional information.

No bid will be accepted nor any contract entered into without proof of the contractor's and subcontractors' current registration with the Department of Industrial Relations to perform public work.

Bidder hereby certifies that it is aware of the registration requirements set forth in Labor Code sections 1725.5 and 1771.1 and is currently registered as a contractor with the Department of Industrial Relations.<sup>1</sup>

Name of Bidder: Bauman Landscapes & Const. Inc.  
DIR Registration Number: 10000 24797  
DIR Registration Expiration: 02/30/2025  
Small Project Exemption:      Yes or X No

Unless Bidder is exempt pursuant to the small project exemption, Bidder further acknowledges:

1. Bidder shall maintain a current DIR registration for the duration of the project.
2. Bidder shall include the requirements of Labor Code sections 1725.5 and 1771.1 in its contract with subcontractors and ensure that all subcontractors are registered at the time of bid opening and maintain registration status for the duration of the project.
3. Failure to submit this form or comply with any of the above requirements may result in a finding that the bid is non-responsive.

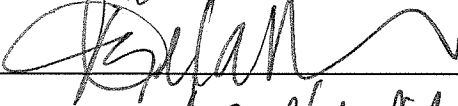
Name of Bidder Bauman Landscapes & Const. Inc.  
Signature   
Name and Title Angela M. Bauman, VP.  
Dated 7/24/2024

<sup>1</sup> If the Project is exempt from the contractor registration requirements pursuant to the small project exemption under Labor Code Sections 1725.5 and 1771.1, please mark "Yes" in response to "Small Project Exemption."

1.9 Contractor's Certificate Regarding Workers' Compensation.

I am aware of the provisions of section 3700 of the Labor Code which require every employer to be insured against liability for workers' compensation or to undertake self-insurance in accordance with the provisions of that code, and I will comply with such provisions before commencing the performance of the work of this Contract.

Name of Bidder Baumanlandscaped const. Inc.  
Signature   
Name Amela M. Bauman  
Title PM  
Dated 7/22/24

**CITY OF SAUSALITO**  
420 Litho Street, Sausalito, CA 94965

**Addendum No. 1**

Issued **July 3, 2024**

**For**  
**2024 Ferry Landside Improvement Project**

Page 1 of 3

---

**NOTICE TO ALL PLAN HOLDERS SUBMITTING BIDS FOR THIS WORK:**

You are hereby notified of the following information, changes, clarifications or modifications to the original Contract Documents, Project Manual, Drawings, Specifications and subsequent Addenda. This Addendum shall supersede the original Contract Documents and previous Addenda wherein it contradicts the same and shall take precedence over anything to the contrary therein. All other conditions remain UNCHANGED.

This Addendum is hereby made a part of the Contract Documents to the same extent as though it were originally included therein.

**RESPONSE TO QUESTIONS**

**QUESTION 1: Could you please provide bid items quantities and units for Alternate E?**

**Response to Question 1:**

Please refer to the "REVISION TO THE PROJECT SPECIFICATIONS" on the next page.

**QUESTION 2: Is the project awarded on base bid or base bid & alternates?**

**Response to Question 2:**

The project will be awarded based on the base bid, as noted in **00 11 16 NOTICE INVITING BIDS** page 8 and **ARTICLE 31. BASIS OF AWARD; BALANCED BID** page 16 of the Project Specifications.

**QUESTION 3: When will the City be going to Council for award?**

**Response to Question 3:**

The project will be awarded on or after July 30th, 2024, which is subject to change.

2024 Ferry Landside Improvement Project  
Addendum No. 1

**QUESTION 4: When are the following documents and attachments due:**  
*Prime Contractor and Subcontractor/Subconsultant/Supplier Report; SBE Goal Declaration; Small Business Enterprise Affidavit of Size, if applicable; and Good Faith Efforts Documentation?*

**Response to Question 4:**

All items indicated above are due with and at the time of the bid submission.

**END RESPONSE TO QUESTIONS**

**REVISION TO PROJECT DOCUMENTS**

**REVISION TO THE PROJECT SPECIFICATIONS**

Replaced  
w/ Addendum  
#2

**REMOVE** in its entirety E. BID SCHEDULE FOR BID ALTERNATIVE 4: EXCLUDE IMPROVEMENTS AT TRACY WAY and **REPLACE** with the below:

**E. BID SCHEDULE FOR BID ALTERNATIVE 4: EXCLUDE IMPROVEMENTS AT TRACY WAY**

NO.	ITEM DESCRIPTION	UNIT OF MEASURE	EST. QTY.	UNIT PRICE	ITEM COST
1.	DEMOLITION (DEDUCT)	SF	3,500		
2.	ASPHALT FULL DEPTH CONFORM (DEDUCT)	TON	20		
3.	TYPE "A" CURB & GUTTER (DEDUCT)	LF	110		
4.	TYPE "E" CURB (DEDUCT)	LF	90		
5.	PEDESTRIAN CONCRETE (EXPOSED AGGREGATE) (DEDUCT)	SF	2,330		
6.	CURB RAMP WITH DETECTABLE WARNING SURFACE (COLONIAL RED) (DEDUCT)	EA	2		
7.	CAST IN PLACE DETECTABLE WARNING SURFACE (COLONIAL RED) (DEDUCT)	EA	1		
8.	ADJUST UTILITY TO GRADE (DEDUCT)	EA	1		
9.	NEW SIGN ON NEW POLE (DEDUCT)	EA	2		

2024 Ferry Landside Improvement Project  
Addendum No. 1

TOTAL BID PRICE BASED ON BID SCHEDULE TOTAL OF UNIT PRICES  
FOR BID ALTERNATIVE 4

\$ \_\_\_\_\_  
Total Bid Price in Numbers

\$ \_\_\_\_\_  
Total Bid Price in Written Form

In case of discrepancy between the written price and the numerical price, the written price shall prevail.

End Revisions to the Project Specifications

**END REVISION TO PROJECT DOCUMENTS**

**END OF ADDENDUM NO. 1**

Issued By: City of Sausalito  
Kevin McGowan  
DPW Director and City Engineer

ACKNOWLEDGED

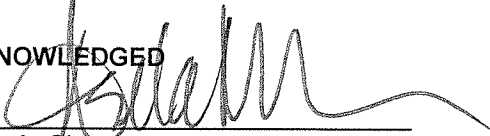
  
\_\_\_\_\_  
Bidder's Signature

A signed copy of this addendum is to be submitted as a part of the bid package for the subject project. Failure to do so may subject the Bidder to Disqualification.

**CITY OF SAUSALITO**  
420 Litho Street, Sausalito, CA 94965

**Addendum No. 3**

Issued **July 18, 2024**

**For**  
**2024 Ferry Landside Improvement Project**

Page 1 of 1

---

**NOTICE TO ALL PLAN HOLDERS SUBMITTING BIDS FOR THIS WORK:**

You are hereby notified of the following information, changes, clarifications or modifications to the original Contract Documents, Project Manual, Drawings, Specifications and subsequent Addenda. This Addendum shall supersede the original Contract Documents and previous Addenda wherein it contradicts the same and shall take precedence over anything to the contrary therein. All other conditions remain UNCHANGED.

This Addendum is hereby made a part of the Contract Documents to the same extent as though it were originally included therein.

Work under Bid Alternative 2 related to placing GravelPave material on Tracy Way to allow the area to be more of a pedestrian friendly walkway, as well as work under the base bid to install improvements to close off the end of Tracy Way as it joins Anchor Street, shall not be initiated prior to approval by the City Council of a vacation of the public right of way on Tracy Way between El Portal to Anchor Street, which shall be approved in accordance with applicable law at the sole discretion of the City Council.

A separate notice to proceed with improvements for the closure of Tracy Way shall be given by the City prior to the commencement of such construction work by the Contractor, and in the event that no vacation of the right of way is granted by the City Council, the City shall issue a deductive change order removing such items from the scope of work for the project in accordance with Bid Alternative 4.

*Handwritten signature*  
**END OF UPDATE**

**END OF ADDENDUM NO. 3**

*Handwritten signature*



## FAIR EMPLOYMENT PRACTICES CERTIFICATE

In connection with the performance of work under this Contract, the Contractor agrees as follows:

1. The Contractor will not willfully discriminate against any employee or applicant for employment because of race, religious creed, color, national origin, ancestry, physical disability, mental disability, medical condition, genetic information, marital status, sex, gender, gender identity, gender expression, age, or sexual orientation, as defined in Government Code Section 12926. The Contractor will take affirmative action to ensure that applicants are employed, and that employees are treated during employment, without regard to their race, color, religious creed, ancestry, national origin, sexual orientation, marital status, physical disability, mental disability, genetic information, age, gender, gender identity, or medical condition as defined in Government Code Section 12926. Such action shall include but not be limited to the following: employment, upgrading, demotion or transfer; recruitment or recruitment advertising; layoff or termination; rates of pay or other forms of compensation; and selection for training including apprenticeship. The Contractor agrees to post in conspicuous places, available to employees and applicants for employment, notices setting forth the provisions of this Fair Employment Practices section.
2. The Contractor will send to each labor union or representative of worker with which he has a collective bargaining agreement or other contract or understanding, a notice, advising the said labor union or workers' representative of the Contractor's commitments under this section, and shall post copies of the notice in conspicuous places available to employees and applicants for employment.
3. The Contractor will permit access to his records of employment, employment advertisements, application forms, and other pertinent data records by the Fair Employment and Housing Commission, the awarding authority or any other appropriate agency of the State of California designated by the awarding authority for the purposes of investigation to ascertain compliance with the Fair Employment Practices section of this Contract.
4. A finding of willful violation of the Fair Employment Practices section of this Contract or of the Fair Employment and Housing Act, Government Code Sections 12900 *et. seq.*, shall be regarded by the awarding authority as a basis for determining the Contractor to be not a "responsible Bidder" as to future contracts for which such Contractor may submit bids, for revoking the Contractor's prequalification rating, if any, and for refusing to establish, re-establish or renew a prequalification rating for the Contractor. The awarding authority shall deem a finding of willful violation of the Fair Employment and Housing Act to have occurred upon receipt of written notice from the Fair Employment and Housing Commission that it has investigated and determined that the Contractor has violated the Fair Employment and Housing Act and has issued an order under Government Code Section 12970 or obtained an injunction under Government Code Section 12973. Upon receipt of such written notice from the Department of Fair Employment and Housing, the awarding authority shall notify the Contractor that unless he demonstrates to the satisfaction of the awarding authority within a stated period that the violation has been corrected, his prequalification rating will be revoked at the expiration of such period.
5. The Contractor agrees that, should the awarding authority determine that the Contractor has not complied with the Fair Employment Practices section of this Contract, then pursuant to Labor Code Sections 1735 and 1775, the Contractor shall, as a penalty to the awarding authority, forfeit for each calendar day, or portion thereof, for each person who was denied employment as a result of such non-compliance, the penalties provided in the Labor Code for violation of prevailing wage rates. Such monies may be recovered from the Contractor. The awarding authority may deduct any such damages from any monies due the Contractor.
6. Nothing contained in the Fair Employment Practices section shall be construed in any manner or fashion so as to prevent the awarding authority from pursuing any other remedies that may be available at law.
7. The Contractor will include the provisions of the foregoing Paragraphs 1 through 6 in every first-tier subcontract, if any, so that such provisions will be binding upon each such subcontractor.
8. Statements and Payrolls. The Contractor shall maintain his records in conformance with the requirements in the Specification and the following provisions:
  - a. The submissions by the Contractor of payrolls, or copies thereof, is required. Each Contractor and subcontractor shall preserve his weekly payroll records for a period of three years from the date of completion of this Contract.
  - b. The payroll records shall contain the name, address, and social security number of each employee, his correct classification, rate of pay, daily and weekly number of hours worked, itemized deductions made and actual wages paid.
  - c. The Contractor shall make his payroll records available at the project site for inspection by CITY

OF SAUSALITO and shall permit CITY OF SAUSALITO to interview employees during working hours on the job.  
 The following certification is to be executed by every Bidder and enclosed and forwarded in a sealed envelope containing the bid. The person signing the certification shall state his address and official capacity.

**FAIR EMPLOYMENT PRACTICES CERTIFICATION**

TO THE CITY OF SAUSALITO:

The undersigned, in submitting a bid for performing the following work by contract, hereby certifies that Bidder will meet the above standards of affirmative compliance with the Fair Employment and Housing Act, Government Code Section 12900, *et. seq.*

<u>7/22/24</u>	<u>construction</u>
DATE	PRODUCT AND SERVICES
<u>1420 Lyon St. SF</u>	<u>Bauman Landscaped Const.</u>
ADDRESS	(TYPE) BIDDING COMPANY
<u>94123 CA 94123</u>	<u>Angela Bauman</u>
ADDRESS STREET	NUMBER & STATE ZIP
<u>94123 CA 94123</u>	SIGNATURE
CITY CODE	NAME OF SIGNER
<u>415 4474000</u>	<u>VP</u>
TELEPHONE	(TYPE) TITLE

## DISQUALIFICATION QUESTIONNAIRE

Has Bidder, any officer of Bidder, or any employee of Bidder who has a proprietary interest in Bidder ever been disqualified, removed, or otherwise prevented from bidding on or completing a federal, state, or local government project because of a violation of law or a safety regulation?

Yes \_\_\_\_\_

No  \_\_\_\_\_

If the answer is yes, explain the circumstances in the following space.

*Note: This questionnaire constitutes as a part of the Proposal, and Bidder's signature on the signature portion of this Proposal shall constitute signature of this questionnaire.*

**BUY AMERICA CERTIFICATE**  
(Steel, Iron or Manufactured Products)

SELECT AND COMPLETE ONLY ONE OF THE FOLLOWING CERTIFICATIONS:\*

Certificate of Compliance with Buy America Requirements

Bidder or Offeror hereby certifies that it will comply with the requirements of 49 U.S.C. 5323(j)(1), and the applicable regulations in 49 CFR Part 661.

Date 7/22/28  
Signature [Handwritten Signature]  
Company Bauman Landscape & Const.  
Name Angela Bauman  
Title VP.

Certificate of Non-Compliance with Buy America Requirements

Bidder or Offeror hereby certifies that it cannot comply with the requirements of 49 U.S.C. 5323(j), but it may qualify for an exception pursuant to 49 U.S.C. 5323(j)(2), as amended, and the applicable regulations in 49 CFR 661.7.

Date \_\_\_\_\_  
Signature \_\_\_\_\_  
Company \_\_\_\_\_  
Name \_\_\_\_\_  
Title \_\_\_\_\_

\*Bidders' attention is directed to Section S10.02, Buy America Requirements, of the Special Provisions.

**EQUAL OPPORTUNITY CERTIFICATION**

Bidder, Bauman Landscape & Const. Inc. proposed subcontractor,

Striping Graphics & CT Electric hereby certifies that he has not participated in a previous contract or subcontract subject to the equal opportunity clauses, as required by Executive Orders 10925, 11114, or 11246, and that, where required, he has filed with the Joint Reporting Committee, the Director of the Office of Federal Contract Compliance, a Federal Government contracting or administering agency, or the former President's Committee on Equal Employment Opportunity, all reports due under the applicable filing requirements.

Note: The above certification is required by the Equal Employment Opportunity Regulations of the Secretary of Labor (41 CFR 60-1.7(b)(1)), and must be submitted by Bidders and proposed subcontractors only in connection with contracts and subcontracts that are subject to the equal opportunity clause. Contracts and subcontracts exempt from the equal opportunity clause are set forth in 41 CFR 60-1.5. (Generally only contracts or subcontracts of \$10,000 or under are exempt.)

Proposed prime contractors and subcontractors who have participated in a previous contract or subcontract subject to the Executive Orders and have not filed the required reports should note that 41 CFR 60-1.7(b)(1) prevents the award of contracts and subcontracts unless such contractor submits a report covering the delinquent period or such other period specified by the Federal Highway Administration or by the Director, Office of Federal Contract Compliance, U.S. Department of Labor.

*Note: Bidder's execution on the signature portion of this Proposal shall also constitute an endorsement and execution of those certifications that are a part of this Proposal.*

## EXHIBIT 10-Q DISCLOSURE OF LOBBYING ACTIVITIES

COMPLETE THIS FORM TO DISCLOSE LOBBYING ACTIVITIES PURSUANT TO 31 U.S.C. 1352

<p><b>1. Type of Federal Action:</b></p> <p><input checked="" type="checkbox"/> a. contract  <input type="checkbox"/> b. grant  <input type="checkbox"/> c. cooperative agreement  <input type="checkbox"/> d. loan  <input type="checkbox"/> e. loan guarantee  <input type="checkbox"/> f. loan insurance</p>	<p><b>2. Status of Federal Action:</b></p> <p><input checked="" type="checkbox"/> a. bid offer/application  <input type="checkbox"/> b. initial award  <input type="checkbox"/> c. post-award</p>	<p><b>3. Report Type:</b></p> <p><input checked="" type="checkbox"/> a. initial  <input type="checkbox"/> b. material change</p> <p style="text-align: center;">For Material Change Only:</p> <p>year _____ quarter _____  date of last report _____</p>
<p><b>4. Name and Address of Reporting Entity:</b></p> <p>Prime _____ Subawardee _____  Tier _____, if known</p> <p>Congressional AGENCY NAME, if known _____</p>	<p><b>5. If Reporting Entity in No. 4 is Subawardee, Enter Name and Address of Prime:</b></p> <p>Congressional AGENCY NAME, if known _____</p>	
<p><b>6. Federal Department/Agency:</b></p>	<p><b>7. Federal Program Name/Description:</b></p> <p>CFDA Number, if applicable _____</p>	
<p><b>8. Federal Action Number, if known:</b></p>	<p><b>9. Award Amount, if known:</b></p>	
<p><b>10. Name and Address of Lobby Entity (If individual, last name, first name, MI)</b></p>	<p><b>11. Individuals Performing Services (including address if different from No. 10) (last name, first name, MI)</b></p>	
<p><b>12. Amount of Payment (check all that apply)</b></p> <p>\$ _____ actual _____ planned _____</p>	<p><b>14. Type of Payment (check all that apply)</b></p> <p><input checked="" type="checkbox"/> a. retainer  <input type="checkbox"/> b. one-time fee  <input type="checkbox"/> c. commission  <input type="checkbox"/> d. contingent fee  <input type="checkbox"/> e. deferred  <input type="checkbox"/> f. other, specify _____</p>	
<p><b>13. Form of Payment (check all that apply):</b></p> <p><input checked="" type="checkbox"/> a. cash  <input type="checkbox"/> b. in-kind; specify nature _____  Value _____</p>		
<p><b>15. Brief Description of Service: Performed or to be performed and Date(s) of Service, including officer(s), employee(s), or member(s) contacted, for Payment Indicated in Item 12:</b></p> <p style="text-align: center;">(attach Continuation Sheet(s) if necessary)</p>		
<p><b>16. Continuation Sheet(s) attached:</b> Yes <input type="checkbox"/> No <input type="checkbox"/></p>		
<p><b>17. Information requested through this form is authorized by Title 31 U.S.C. Section 1352. This disclosure of lobbying reliance was placed by the tier above when his transaction was made or entered into. This disclosure is required pursuant to 31 U.S.C. 1352. This information will be reported to Congress semiannually and will be available for public inspection. Any person who fails to file the required disclosure shall be subject to a civil penalty of not less than \$10,000 and not more than \$100,000 for each such failure.</b></p>		
		<p>Signature: _____  Print Name: _____  Title: _____  Telephone No.: _____</p>

Federal Use Only:

Authorized for Local Reproduction

Standard Form - LLL Standard Form LLL Rev. 04-28-06  
Distribution: Orig- Local Agency Project Files

Page 1

Contract No. 2023-BT-072

## INSTRUCTIONS FOR COMPLETING Attachment L DISCLOSURE OF LOBBYING ACTIVITIES

This disclosure form shall be completed by the reporting entity, whether sub awardee or prime federal recipient at the initiation or receipt of covered federal action or a material change to previous filing pursuant to title 31 U.S.C. Section 1352. The filing of a form is required for such payment or agreement to make payment to lobbying entity for influencing or attempting to influence an officer or employee of any agency, a Member of Congress an officer or employee of Congress or an employee of a Member of Congress in connection with a covered federal action. Attach a continuation sheet for additional information if the space on the form is inadequate. Complete all items that apply for both the initial filing and material change report. Refer to the implementing guidance published by the Office of Management and Budget for additional information.

1. Identify the type of covered federal action for which lobbying activity is or has been secured to influence, the outcome of a covered federal action.
2. Identify the status of the covered federal action.
3. Identify the appropriate classification of this report. If this is a follow-up report caused by a material change to the information previously reported, enter the year and quarter in which the change occurred. Enter the date of the last, previously submitted report by this reporting entity for this covered federal action.
4. Enter the full name, address, city, state, and zip code of the reporting entity. Include Congressional CITY OF SAUSALITO if known. Check the appropriate classification of the reporting entity that designates if it is or expects to be a prime or subaward recipient. Identify the tier of the sub awardee, e.g., the first sub awardee of the prime is the first tier. Subawards include but are not limited to: subcontracts, subgrants, and contract awards under grants.
5. If the organization filing the report in Item 4 checks "Sub awardee" then enter the full name, address, city, state, and zip code of the prime federal recipient. Include Congressional CITY OF SAUSALITO, if known.
6. Enter the name of the federal agency making the award or loan commitment. Include at least one organization level below City of Sausalito, if known. For example, Department of Transportation, United States Coast Guard.
7. Enter the federal program name or description for the covered federal action (item 1). If known, enter the full Catalog of Federal Domestic Assistance (CFDA) number for grants, cooperative agreements, loans and loan commitments.
8. Enter the most appropriate federal identifying number available for the federal action identification in item 1 (e.g., Request for Proposal (RFP) number, Invitation for Bid (IFB) number, grant announcement number, the contract grant or loan award number, the application/proposal control number assigned by the federal agency). Include prefixes, e.g., "RFP-DE-90-001."
9. For a covered federal action where there has been an award or loan commitment by the Federal agency, enter the federal amount of the award/loan commitments for the prime entity identified in item 4 or 5.
10. Enter the full name, address, city, state, and zip code of the lobbying entity engaged by the reporting entity identified in Item 4 to influence the covered federal action.
11. Enter the full names of the individual(s) performing services and include full address if different from 10 (a). Enter Last Name, First Name and Middle Initial (MI).
12. Enter the amount of compensation paid or reasonably expected to be paid by the reporting entity (Item 4) to the lobbying entity (Item 10). Indicate whether the payment has been made (actual) or will be made (planned). Check all boxes that apply. If this is a material change report, enter the cumulative amount of payment made or planned to be made.
13. Check all boxes that apply. If payment is made through an in-kind contribution, specify the nature and value of the in-kind payment.
14. Check all boxes that apply. If other, specify nature.
15. Provide a specific and detailed description of the services that the lobbyist has performed or will be expected to perform and the date(s) of any services rendered. Include all preparatory and related activity not just time spent in actual contact with federal officials. Identify the federal officer(s) or employee(s) contacted or the officer(s) employee(s) or Member(s) of Congress that were contacted.
16. Check whether or not a continuation sheet(s) is attached.
17. The certifying official shall sign and date the form, and print his/her name title and telephone number. Public reporting burden for this collection of information is estimated to average 30-minutes per response, including time for reviewing instruction, searching existing data sources, gathering and maintaining the data needed, and completing and reviewing the collection of information. Send comments regarding the burden estimate or any other aspect of this collection of information, including suggestions for reducing this burden, to the Office of Management and Budget, Paperwork Reduction Project (0348-0046), Washington, D.C. 20503. SF- LLL-Instructions Rev. 06-04

**CITY OF SAUSALITO  
 BIDDER'S STATEMENT OF QUALIFICATIONS AND BUSINESS  
 REFERENCES**

Name of Bidder Bauman Landscape & Const.  
 Address of Principal Office 2920 Lyon St. SF CA 94123

1. Are you an individual , a partnership , a corporation , an LLC  or a joint venture ?  
 (Check as applicable)

If a partnership, list names and addresses of partners; if a corporation, list names of officers and directors and State of incorporation; if a joint venture, list names and addresses of venturers and if any venturer is a corporation, partnership or joint venture; list the same information for each such corporation, partnership and joint venture.

2. 251478 Are you licensed as a Contractor to do business in California? YES  
 License No. 251478 Classification(s) \_\_\_\_\_  
 DIR Registration No. 100006406

For the following questions, if a joint venture, give information for each of the venturers by name. Attach additional sheets if necessary.

3. How many years has your organization been in business as a Contractor under your present business name? 45

4. How many years of experience has your organization had in construction work similar to the work you are interested in bidding?

(a) As a general Contractor? 45  
 (b) As a subcontractor? 45

5a. Show **all** the projects your organization has completed during at least the last five (5) years in the following tabulation: For joint venture work, show the sponsoring individual or company. The information provided must show a minimum experience of three (3) similar pavement and parking lot rehabilitation work projects in scope and size, and three (3) public works projects in the past five (5) years. **For subcontractors, if any, also provide information demonstrating that each subcontractor has a minimum experience of three similar projects in scope and size, and one (1) public works project in the past five (5) years.**

Year	Type of Work	Value of Work	Location	For Whom
------	--------------	---------------	----------	----------



---

---

---

5b. The solar electric system subcontractor (if any and if such work is not performed by Contractor) qualification shall comply with the Special Provisions Section S7.07 to be qualified for this Project.

Solar Electric System subcontractor:  
Name:

Address:

Contact Person: \_\_\_\_\_ Tel: \_\_\_\_\_  
Provide at least three (3) completed projects within the last five (5) years.

Year	Value of Work	Location	Reference name and telephone
------	---------------	----------	------------------------------

*see attached*

6. Have you or your organization, or any officer or partner thereof, failed to complete a contract? If so, give details.

*No*

7. In what other lines of business are you financially interested?

*None*

8. Name the persons with whom you have been associated in business as partners or business associates in each of the last five (5) years.

None

9. Give information below about the construction experience of the principal individuals of your present organization, including those individuals to be in responsible charge of this Project.

Individual's Name	Present Position or Office	Years of Construction Experience	Type of Work	In What Capacity
-------------------	----------------------------	----------------------------------	--------------	------------------

\_\_\_\_\_  
\_\_\_\_\_  
\_\_\_\_\_  
\_\_\_\_\_

10. Give information below about all your contract work underway or for which you are committed.

Type of Work	Location	Value	Percent Complete	Scheduled Completion Date	For Whom Performed
--------------	----------	-------	------------------	---------------------------	--------------------

\_\_\_\_\_  
\_\_\_\_\_  
\_\_\_\_\_  
\_\_\_\_\_  
\_\_\_\_\_

11. References: Give only engineers, architects, or owners, including public bodies, for whom you have done work.



**BAUMAN**  
LANDSCAPE CONSTRUCTION  
GENERAL SITEWORK

## **Bidder's Questionnaire**

### **Pickleweed Park Enhancement Project**

#### **5.1 Six Most recently completed public works projects within the last three years:**

**1. Project Name: Chestnut Streetscape**

Location: San Fransico, CA

Project Description: Streetscape

Owner: San Francisco Public Works

Prime GC: Bauman Landscape and Construction, Inc.

Architect/Engineer: SF Public Works Design & Engineering

Project Manager: Angela Bauman, [angela@baumanland.com](mailto:angela@baumanland.com), 415-447-4800

Work Performed: Paving, Underground utilities, electrical, sewer, etc.

Start Date: 6/2017      Planned Completion Date: 12/2018      Actual Comp. Date: 12/2018

Contract Amount: \$4,625,122.00      Change Order Amount: \$465,380.00

Time Extensions: N/A

Stop Notices: N/A

Liquidated Damages: \$0

Claims: N/A

**2. Project Name: Van Ness Corridor**

Location: San Fransico, CA

Project Description: Streetscape

Owner: San Francisco Municipal Transportation Agency

Prime GC: Walsh Construction Company

Architect/Engineer: N/A

Project Manager: Angela Bauman, [angela@baumanland.com](mailto:angela@baumanland.com), 415-447-4800

Work Performed: Pavers, Landscaping, irrigation, concrete, etc.

Start Date: 2018      Planned Completion Date: 2020      Actual Comp. Date: 2021

Contract Amount: \$33,000,000.00      Change Order Amount: Included

Time Extensions: N/A

Stop Notices: N/A

Liquidated Damages: \$0

Claims: N/A

**3. Project Name: Various Locations No. 50**

Location: San Francisco, CA

Project Description: Streetscape

Owner: San Francisco Public Works

Prime GC: Bauman Landscape and Construction, Inc.

Architect/Engineer: SF Public Works Bureau of Engineering

Project Manager: Angela Bauman, [angela@baumanland.com](mailto:angela@baumanland.com), 415-447-4800

Work Performed: Concrete, AC Pave, Sewer, etc.

Start Date: 2022      Planned Completion Date: 2023      Actual Comp. Date: 2023

Contract Amount: \$2,300,000.00      Change Order Amount: Included

Time Extensions: N/A

Stop Notices: N/A

Liquidated Damages: \$0

Claims: N/A

**4. Project Name: 22<sup>nd</sup> Green Connection**

Location: San Fransico, CA

Project Description: Streetscape

Owner: San Francisco Public Works

Prime GC: Bauman Landscape and Construction, Inc.

Architect/Engineer: SF Public Works Design & Engineering

Project Manager: Angela Bauman, [angela@baumanland.com](mailto:angela@baumanland.com), 415-447-4800

Work Performed: Paving, Underground utilities, electrical, sewer, etc.

Start Date: 2018      Planned Completion Date: 2020      Actual Comp. Date: 2020

Contract Amount: \$3,316,348.00      Change Order Amount: Included

Time Extensions: N/A

Stop Notices: N/A

Liquidated Damages: \$0

Claims: N/A

**5. Project Name: Veteran's Memorial Parking Lot**

Location: San Rafael, CA

Project Description: Parking Lot at Civic Center – San Rafael

Owner: County of Marin

Prime GC: Bauman Landscape and Construction, Inc.

Architect/Engineer: BKF Engineers

Project Manager: Angela Bauman, [angela@baumanland.com](mailto:angela@baumanland.com), 415-447-4800

Work Performed: new parking lot, Subgrade repairs, new drainage system, irrigation, landscaping

Start Date: 10/2023      Planned Completion Date: 06/2024      Actual Comp. Date: 06/2024

Contract Amount: \$7,000,000.00

Change Order Amount: \$500,000.00

Time Extensions: N/A

Stop Notices: N/A

Liquidated Damages: \$0

Claims: N/A

**6. Project Name: Maxwell Farms Regional Park**

Location: Sonoma, CA

Project Description: Park Renovation

Owner: County of Sonoma

Prime GC: Bauman Landscape and Construction, Inc.

Architect/Engineer: BKF Engineers

Project Manager: Angela Bauman, [angela@baumanland.com](mailto:angela@baumanland.com), 415-447-4800

Work Performed: Improv. To Existing park Facilities including parking area w/lighting, synthetic turf baseball field, new pathways, site furnishings, landscape planting and irrigation and utility improvements.

Start Date: 2022          Planned Completion Date: 2023          Actual Comp. Date: 2023

Contract Amount: \$7,300,000.00          Change Order Amount: Included

Time Extensions: N/A

Stop Notices: N/A

Liquidated Damages: \$0

Claims: N/A



## **5.2 Three largest completed projects within the last three years:**

### **1. Project Name: Van Ness Corridor**

Location: San Francisco, CA

Project Description: Streetscape

Owner: San Francisco Municipal Transportation Agency

Prime GC: Walsh Construction Company

Architect/Engineer: N/A

Project Manager: Angela Bauman, [angela@baumanland.com](mailto:angela@baumanland.com), 415-447-4800

Work Performed: Pavers, Landscaping, irrigation, concrete, etc.

Start Date: 2018      Planned Completion Date: 2020      Actual Comp. Date: 2021

Contract Amount: \$33,000,000.00                      Change Order Amount: Included

Time Extensions: N/A

Stop Notices: N/A

Liquidated Damages: \$0

Claims: N/A

**2. Project Name: Veteran's Memorial Parking Lot**

Location: San Rafael, CA

Project Description: Parking Lot at Civic Center – San Rafael

Owner: County of Marin

Prime GC: Bauman Landscape and Construction, Inc.

Architect/Engineer: BKF Engineers

Project Manager: Angela Bauman, [angela@baumanland.com](mailto:angela@baumanland.com), 415-447-4800

Work Performed: new parking lot, Subgrade repairs, new drainage system, irrigation, landscaping

Start Date: 10/2023      Planned Completion Date: 06/2024      Actual Comp. Date: 06/2024

Contract Amount: \$7,000,000.00

Change Order Amount: \$500,000.00

Time Extensions: N/A

Stop Notices: N/A

Liquidated Damages: \$0

Claims: N/A

### **3. Project Name: Maxwell Farms Regional Park**

Location: Sonoma, CA

Project Description: Park Renovation

Owner: County of Sonoma

Prime GC: Bauman Landscape and Construction, Inc.

Architect/Engineer: BKF Engineers

Project Manager: Angela Bauman, [angela@baumanland.com](mailto:angela@baumanland.com), 415-447-4800

Work Performed: Improv. To Existing park Facilities including parking area w/lighting, synthetic turf baseball field, new pathways, site furnishings, landscape planting and irrigation and utility improvements.

Start Date: 2022          Planned Completion Date: 2023          Actual Comp. Date: 2023

Contract Amount: \$7,300,000.00          Change Order Amount: Included

Time Extensions: N/A

Stop Notices: N/A

Liquidated Damages: \$0

Claims: N/A

**5.3 Any project which is similar to this project including scope and character of the work:**

**Project Name: Maxwell Farms Regional Park**

Location: Sonoma, CA

Project Description: Park Renovation

Owner: County of Sonoma

Prime GC: Bauman Landscape and Construction, Inc.

Architect/Engineer: BKF Engineers

Project Manager: Angela Bauman, [angela@baumanland.com](mailto:angela@baumanland.com), 415-447-4800

Work Performed: Improv. To Existing park Facilities including parking area w/lighting, synthetic turf baseball field, new pathways, site furnishings, landscape planting and irrigation and utility improvements.

Start Date: 2022      Planned Completion Date: 2023      Actual Comp. Date: 2023

Contract Amount: \$7,300,000.00      Change Order Amount: Included

Time Extensions: N/A

Stop Notices: N/A

Liquidated Damages: \$0

Claims: N/A

Name	Address	Telephone	Email	Business
------	---------	-----------	-------	----------

-----

-----

-----

-----

-----

-----

12. Reference is hereby made to the following bank or banks as to the financial responsibility of the Bidder:

(a) Name of Bank: Five Star Bank  
 Address: Street \_\_\_\_\_  
 City and State SP, CA Telephone \_\_\_\_\_  
Sergey Officer Familiar with Bidder's Account: Sergey 415 769 7759

(b) Name of Bank: \_\_\_\_\_  
 Address: Street \_\_\_\_\_  
 City and State \_\_\_\_\_ Telephone \_\_\_\_\_  
 Officer Familiar with Bidder's Account: \_\_\_\_\_

(c) Name of Bank: \_\_\_\_\_  
 Address: Street \_\_\_\_\_  
 City and State \_\_\_\_\_ Telephone \_\_\_\_\_  
 Officer Familiar with Bidder's Account: \_\_\_\_\_

13. Reference is hereby made to the following surety company or companies as to the financial responsibility and general reliability of the Bidder:

(a) Name of Surety Company ATP Gallagher 415 574 9300  
 Name of Local Agent (if different) \_\_\_\_\_  
 Local Address: Street SP, CA  
Judith Robinson City and State \_\_\_\_\_ Telephone \_\_\_\_\_  
 Officer Familiar with Bidder's Account: \_\_\_\_\_

(b) Name of \_\_\_\_\_ of \_\_\_\_\_ Surety Company  
 Name of \_\_\_\_\_ of \_\_\_\_\_ Local Agent (if different)

Local Address: Street \_\_\_\_\_ City and State \_\_\_\_\_



**SBE GOAL DECLARATION**

Bauman Landscapes Const Inc  
 Prime Contractor

**03.01.001 and Ferry Landside Improvement Project**  
 Contract Number and Name

- a)  **Check one or more that apply:**  
 \_\_\_\_\_ The Bidder/Proposer is a certified SBE in accordance with CITY OF SAUSALITO standards. A copy of our Certification (and, if required, Affidavit of Size) is enclosed.  
 \_\_\_\_\_ The Bidder/Proposer commits to subcontract at least \_\_\_\_\_ % of its Total Bid Price with one or more certified SBEs for a Commercially Useful Function in the performance of the Contract.  
 \_\_\_\_\_ The Bidder/Proposer has NOT met the contract SBE goal and is not itself a certified SBE.

All Bidders must submit documentation of a verifiable Good Faith Effort with their Bid Proposal.

\_\_\_\_\_  
 Signature 2/22/24  
Date

**Documents to Be Included with Bid with SBE Goal**

	Invitation for Bid
SBE Goal Declaration	X
List of Subcontractors	X
Prime Contractor and Subcontractor/Subconsultant/Supplier Report	X
List of SBEs	X
Copies of SBE Certifications	X
Small Business Enterprise Affidavit of Size (as required; see list of acceptable certifications)	X
Good Faith Efforts Documentation	X

**SMALL BUSINESS ENTERPRISE AFFIDAVIT OF SIZE**

**Who should submit this form:**

If your business was certified by any of the following, please complete and submit this form with a copy of your Certification. This form may be used for Prime Contractors, Subcontractors, Subconsultants, and Suppliers. Your firm's average annual gross receipts must fall below the U.S. Small Business Administration (SBA) industry-specific size cap and in no case exceed \$30.72 million. (View SBA size table here: <https://www.sba.gov/content/table-small-business-size-standards> and click on size standards table link at bottom of web page.)

- SMBE/SWBE Certification by state other than California.
- SB/MICRO/SB-PW Certification by the California Department of General Services (DGS).
- SBA 8(a) Certification by the Small Business Administration.
- SBE/MBE/WBE Certification by other California county or local government-certifying agency or out-of-state government-certifying agency that conform with CITY OF SAUSALITO requirements.

See Special Provisions S11.02, SBE Eligibility, subsections A.1.a. and A.1.b., for further information on business size, and subsection B for list of all acceptable certifications.

I HEREBY DECLARE AND AFFIRM that I am the

\_\_\_\_\_ (Title)  
and duly authorized representative of \_\_\_\_\_

whose address is \_\_\_\_\_ (Name of Firm)

and whose phone is \_\_\_\_\_

I HEREBY DECLARE AND AFFIRM that the firm is a Small Business Enterprise (SBE) in accordance with CITY OF SAUSALITO (CITY OF SAUSALITO) standards as defined in its Diversity Program for Contracts. The firm is certified as of the date that the CITY OF SAUSALITO receives the bid/proposal for **Contract No. 0301001-000, FERRY LANDSIDE IMPROVEMENT PROJECT.**

**I will provide the certification to document this fact with this enclosure.**

I DO SOLEMNLY DECLARE AND AFFIRM UNDER THE PENALTIES OF PERJURY THAT THE CONTENTS OF THE FOREGOING STATEMENTS ARE TRUE AND CORRECT, AND THAT I AM AUTHORIZED, ON BEHALF OF THE ABOVE FIRM, TO MAKE THIS AFFIDAVIT.

\_\_\_\_\_ (Date)      \_\_\_\_\_ (Affiant)      \_\_\_\_\_ (Title)  
*7/22/24*      *[Signature]*      *corp. secretary*



**GOOD FAITH EFFORTS DOCUMENTATION**

**Instructions: Bidder must document Good Faith Efforts to meet the contract-specific SBE goal of 25.5%, even if the Bidder has met the goal. This form protects the Bidder's eligibility for award of the contract if the City of Sausalito determines that the Bidder failed to meet the goal for various reasons, e.g., a DBE/SBE firm was not certified at bid opening, or the Bidder made a mathematical error.**

Contract # and Name: Contract No. 03.01.001 and Ferry Landside Improvement Project  
Bidder's Name: \_\_\_\_\_  
Address: \_\_\_\_\_  
Phone: \_\_\_\_\_ Fax: \_\_\_\_\_  
Owner or Contact Person: \_\_\_\_\_ Title: \_\_\_\_\_  
E-mail: \_\_\_\_\_

Bidder must provide a narrative description of steps taken to obtain SBE participation, including the following elements: (Please attach additional sheets as necessary.)

- A. *A Company representative attended the pre-bid meeting.* Yes \_\_\_ No \_\_\_
- B. *Soliciting SBEs to participate through all reasonable and available means within sufficient time to allow the SBEs to respond to the solicitation.*

List the names and dates of each publication in which a request for SBE participation for this project was placed by the bidder (**attach copies of advertisements**).

Publications	Dates of Advertisements
<i>see attached</i>	

- C. *Selecting portions of the work that are economically feasible for SBEs.*
- List items of work which the bidder made available to SBEs, including, where appropriate, any breaking down of the contract work items (including those items normally performed by the bidder with its own forces) into economically feasible units to facilitate SBE participation. It is the bidder's responsibility to demonstrate that sufficient work to facilitate SBE participation was made available to SBEs.

Items of Work	Breakdown of Items



**User Notes**

[7/8/2024] Angela Bauman : Email Sub quotes to estimating@baumanland.com [Edit](#)

Note Text  Enter Note

[Documents](#) [Project Actions](#)

Select Interest  
 Yes No Maybe

**JUL 22 FERRY LANDSIDE IMPROVEMENT PROJECT**  
 Location: Intersection of Tracy Way & El Portal Sausalito Marin CA  
 When: 2:00 PM

Status: Bidding BIN #:   
 Postponed: No   
 Bid Time: 2:00 PM   
 Status: Bidding Postponed: No   
 Public Works:   
 Street: Intersection of Tracy Way & El Portal City: Sausalito   
 County: Marin Zip Code:

Pre Bid:   
 7/11 @ 2 PM (Meet at Sausalito City Hall, 420 Litho St., Sausalito, CA 94965) [Mandatory: No]

Project Type: Public Works Bid Packages: No   
 Estimate Low: Estimate High: \$1,263,742   
 Contract#/Ref: Published Date: 6/25/2024

Plan Status: Online Spec Status: Online   
 Plans Cost:

**Description:**  
 The Project is located near the intersection of Tracy Way and El Portal and is generally described as follows: the expansion of the existing concrete pedestrian plaza at the Ferry Landing including but not limited to demolition, new concrete flatwork, new curb, gutter and sidewalk, ADA parking stalls, utility trenching and utility installation, landscaping and irrigation, pavement grinding, pavement marking and striping, as shown on the plans.  
 This Project requires a valid California contractor's license for the following classification(s): A-General Engineering Contractor.  
 All bid questions must be in writing and can be emailed to Kevin McGowan at: kmcgowan@sausalito.gov AND to Sara Khorshidifard at: skhorshidifard@sausalito.gov. The last day to submit questions prior to bid opening is Thursday, July 18, 2024.

**Bid Date Information**

Bid Date	Bid Time	Extended	Bid Date Change
7/22/2024	2:00 PM	No	No

**Addenda & Updates**

Number	Type	Entered
0	Memo	7/8/2024
0	Memo	7/16/2024
0	Memo	7/19/2024

Number	Type	Entered
1	Addenda	7/8/2024
2	Addenda	7/16/2024
3	Addenda	7/18/2024

**Additional Documents Links**

Document (Please use links to view these docs)

Planholders List [07-08-24](#)

Planholders List [07-19-24](#)

**Project Contacts**

**Owner**

---

**City of Sausalito, DPW**

**Bidders**

Send Email to Bidders

\* = Confirmed Bidder / Plan Holder

**General Contractor**

**Bauman Landscape & Construction \***  
[angela@baumanland.com](mailto:angela@baumanland.com)  
 Ph:(415) 447-4800      **San Francisco CA**

**CF Contracting, Inc.**  
[cfocontracting@gmail.com](mailto:cfocontracting@gmail.com)  
 Ph:(415) 721-7160      **Fairfax CA**

**Geostructural Engineering \*\***  
[andre.hawks@geostructuralengineering.com](mailto:andre.hawks@geostructuralengineering.com)  
 Ph:(707) 322-3507      **Pleasant Hill CA**

**Ghilotti Brothers Inc \*\***  
[ryans@ghilottibros.com](mailto:ryans@ghilottibros.com)  
 Ph:(415) 454-7011      **San Rafael CA**

**Granite Construction Co. \*\***  
[northcoastestimating@gcinc.com](mailto:northcoastestimating@gcinc.com)  
 Ph:(707) 467-4114      **Ukiah CA**

We are requesting proposals from DBE/SBE subcontractors and material suppliers for all scopes of work. Please send all quotes

**Ground Control, Inc. \*\***  
[Jae@groundci.com](mailto:Jae@groundci.com)  
 Ph:(415) 508-8589      **San Francisco CA**

**Kerex Engineering \*\***  
[hector@kerexengineering.com](mailto:hector@kerexengineering.com)  
 Ph:(925) 457-7165      **Pleasant Hill CA**

Kerex Engineering Inc is soliciting quotes from DBE Subcontractors, Material Suppliers, and Truckers.

**M3 Integrated Services, Inc. \*\***  
[Matt@m3-co.com](mailto:Matt@m3-co.com)  
 Ph:(707) 791-7884      **Santa Rosa CA**

**Maggiora & Ghilotti Inc \*\***  
[kevin@maggiora-ghilotti.com](mailto:kevin@maggiora-ghilotti.com)  
 Ph:(415) 459-8640      **San Rafael CA**

[estimating@rkenginc.com](mailto:estimating@rkenginc.com)

Ph:(415) 859-5505 San Francisco CA

**RWR Construction \*\***

[reception@rwr-inc.com](mailto:reception@rwr-inc.com)

Ph:(415) 457-5658 San Rafael CA

**Valentine Corporation \*\***

[cwalsh@valentinecorp.com](mailto:cwalsh@valentinecorp.com)

Ph:(415) 453-3732 San Rafael CA

**Concrete/Masonry Contractor**

**Zapa Construction, Inc. \*\***

[zapaconstructioninc@gmail.com](mailto:zapaconstructioninc@gmail.com)

Ph:(310) 754-5217 Orinda CA

**Consultant**

**Tully Consulting Group**

[Estimating@tullygroup.com](mailto:Estimating@tullygroup.com)

Ph:(707) 693-1926 Dixon CA

SWPPP & WPCP plans and inspection services. DBE/WBE/SBE

**Verux, Inc.**

[Sierra@veruxinc.com](mailto:Sierra@veruxinc.com)

Ph:(916) 930-6000 Sacramento CA

**Electrical Contractor**

**Delao Electric \*\***

[billdelao@sbcglobal.net](mailto:billdelao@sbcglobal.net)

Ph:(415) 681-7011 San Francisco CA

**Gremelli Industries**

[gvivaldi@gremelli.com](mailto:gvivaldi@gremelli.com)

Ph:(415) 272-3868 Richmond CA

Woman Owned SB Business Certified

**Equipment**

**Cal-West Rentals, Inc.**

[ronnie@calwestrentals.com](mailto:ronnie@calwestrentals.com)

Ph:(707) 540-5109 Petaluma CA

Multiple Full Line Rental Yards: San Mateo, San Rafael, Petaluma proudly serving the Bay Area - WBE Certified - Small Tools -

**Pacific Highway Rentals LLC**

[james@pacifichighwayrentals.com](mailto:james@pacifichighwayrentals.com)

Ph:(510) 569-5656 Dixon CA

Traffic Control Equipment: PCMS, Temp Signals, Afads, Attenuators, Cone Trucks, Radar Signs, Afads, Light Towers, Water Wall,

**Sub-Contractor/Specialty Contractor**

**D&M Traffic Services**

[MorganG@dmtraffic.com](mailto:MorganG@dmtraffic.com)

Ph:(408) 436-1127 Santa Clara CA

D&M Traffic Services is a SBE Supplier that offers a full array of Traffic Control Equipment for Rent or Sale such as: Arrow B

**DR Traffic Control LLC**

LBE, DBE, LSB, MBE, SBE, Micro SB certified, traffic control plans, permit assistance, traffic control set-up, flagging, de-pol

**Pavement Recycling Systems, Inc.**

[tgallinetti@pavementrecycling.com](mailto:tgallinetti@pavementrecycling.com)

Ph:(951) 682-1091 **Jurupa Valley CA**

Providing the largest fleet of Cold Milling Machines in California and Nevada in addition to Rumble Strips, Stabilization, Full

**Total Traffic Control**

[keithr@totaltc.com](mailto:keithr@totaltc.com)

Ph:(415) 963-0427 **San Francisco CA**

DBE Certified / Traffic Control / PCMS Boards / Radar Feedback Signs / Traffic Plans / Construction Area Signs / Sales / Perm

**Supplier**

**Blain Stumpf Construction Fence Re...**

[info@bstfencerental.com](mailto:info@bstfencerental.com)

Ph:(530) 622-4450 **Placerville CA**

Temporary construction fence

**Trucking**

**Tej Trucking, Inc.**

[shalini@tejtruckinginc.com](mailto:shalini@tejtruckinginc.com)

Ph:(510) 963-0483 **Hayward CA**

DBE, MBE, Alameda County SLEB Certified Trucking Co.and Landscaping Material/Aggregates Supplier

**Waste Management Services**

**Pacific Sanitation**

[jroyjr@pacificsanitation.com](mailto:jroyjr@pacificsanitation.com)

Ph:(707) 838-2597 **Windsor CA**

We offer Temp Fence, Portable Toilets, Concrete Washouts and Debris Box hauling and debris recycling services.

## Angela Bauman

---

**From:** Ahmed Alnajm  
**Sent:** Monday, July 22, 2024 12:53 PM  
**To:** Angela Bauman; Mike Bauman; Estimating  
**Subject:** Fwd: FERRY LANDSIDE IMPROVEMENT PROJECT ELECTRIC QUOTE  
**Attachments:** Ferry Landslide Improvement Project\_QUOTE DE.pdf; Affidavit of size to be completed by subs.pdf; Confirmation of Participation to be completed by Subs\_OK.pdf

Ahmed Alnajm

Safety Manger and Estimator, Bauman Landscape & Construction



---

📍 [San Francisco, CA](#) 🌐 [www.baumanland.com](http://www.baumanland.com)

☎️ [\(415\)447-4800](tel:(415)447-4800) 📠 [415-447-4800](tel:415-447-4800)

✉️ [ahmed@baumanland.com](mailto:ahmed@baumanland.com)

---

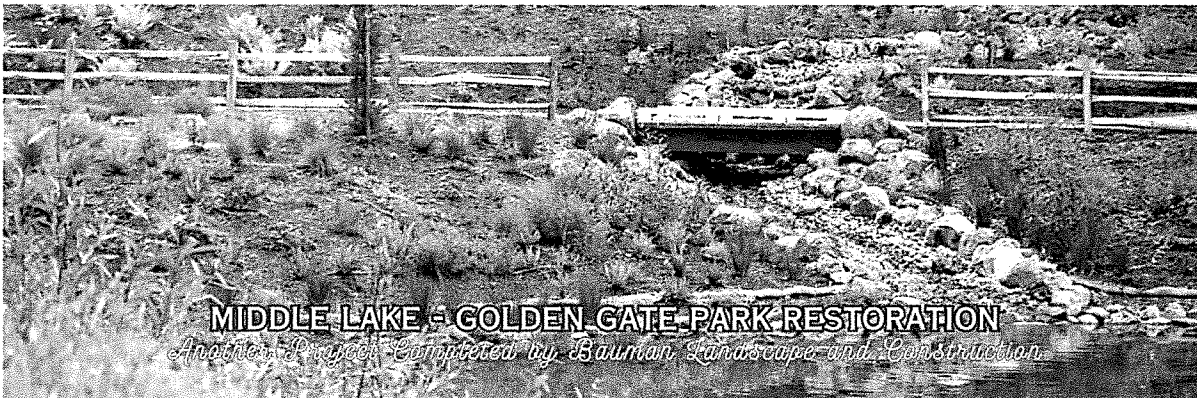

---

**From:** William Delao <[billdelao@sbcglobal.net](mailto:billdelao@sbcglobal.net)>  
**Sent:** Monday, July 22, 2024 12:13:59 PM  
**Subject:** FERRY LANDSIDE IMPROVEMENT PROJECT ELECTRIC QUOTE

Good Afternoon,

## Angela Bauman

---

**From:** Saniha Jain <sjain@sandis.net>  
**Sent:** Monday, July 22, 2024 12:26 PM  
**Cc:** Bruce Chu; Behnaz Davis  
**Subject:** Construction Survey Staking Proposal for Ferry Landside Improvement Project  
**Attachments:** 224334.072224.pdf

Hi Team,

Please find the attached bid proposal for construction staking services on the Ferry Landside Improvement Project project in Sausalito. Let us know if you have any questions. Thank you for your time and consideration.

Respectfully,

Saniha Jain

Construction Survey Staking Estimator

[sjain@sandis.net](mailto:sjain@sandis.net)

1700 S. Winchester Blvd., Suite 200 | Campbell, CA 95008

[Facebook](#) | [LinkedIn](#) | [Instagram](#)

This message may contain confidential information that is for the sole use and benefit of the individual or entity to whom Sandis has performed these services. If you are not the intended recipient please destroy the original transmission and its attachments without reading or saving in any manner and you are hereby notified that any disclosure, copying, and distribution or use of any of the information contained in or attached to this transmission is STRICTLY PROHIBITED.

## Angela Bauman

---

**From:** Ahmed Alnajm  
**Sent:** Monday, July 22, 2024 11:58 AM  
**To:** Mike Bauman  
**Cc:** Angela Bauman; Estimating  
**Subject:** FW: Ferry Landside Improvement Project

**Ahmed Alnajm**  
Safety Manger and Estimator, Bauman Landscape & Construction



---

📍 San Francisco, CA 🌐 [www.baumanland.com](http://www.baumanland.com)

☎ (415)447-4800 📠 415-447-4800

✉ [ahmed@baumanland.com](mailto:ahmed@baumanland.com)

---

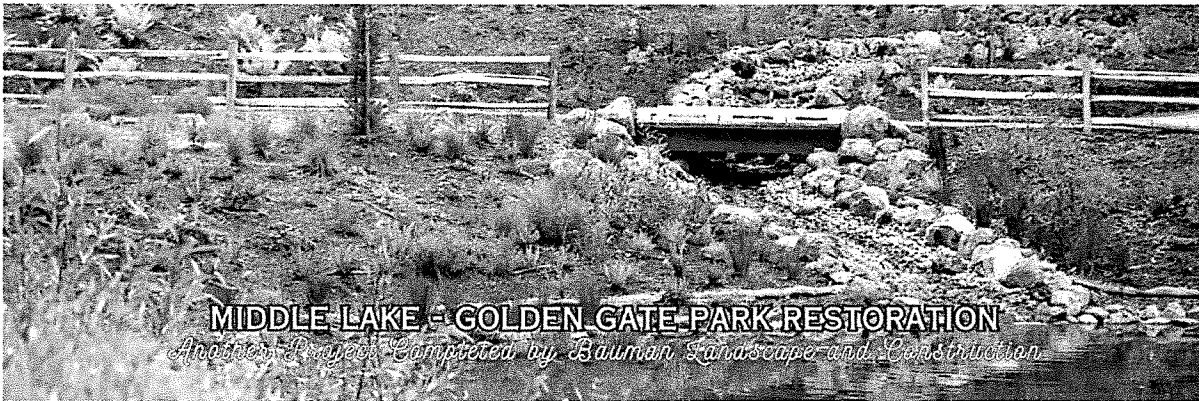

**From:** Denise Baker <[dbaker@constructionsurveyinc.com](mailto:dbaker@constructionsurveyinc.com)>  
**Sent:** Monday, July 22, 2024 11:47 AM  
**To:** Ahmed Alnajm <[ahmed@baumanland.com](mailto:ahmed@baumanland.com)>  
**Cc:** Mike Bauman <[mikeb@baumanland.com](mailto:mikeb@baumanland.com)>; Angela Bauman <[angela@baumanland.com](mailto:angela@baumanland.com)>  
**Subject:** RE: Ferry Landside Improvement Project

Yes, I'm aware of that. But the surveying will be done by the City (according to plans & specs).

If they decide not to do it, we could do it for \$4,000 per monument and \$5,000 per benchmark.

Thanks,



Hi Ahmed,

The plans & specs indicate that the City will be referencing monuments/benchmarks, and you'll coordinate with them if any need to be replaced.

Call me on my mobile if you have any questions.

Thanks,

*Denise Baker, L.S.*

**Construction Survey, Inc.**

**800 Bancroft Way, #201**

**Berkeley, CA 94710**

510-526-0993 office | 925-330-1266 cell

**From:** Ahmed Alnajm <[ahmed@baumanland.com](mailto:ahmed@baumanland.com)>

**Sent:** Monday, July 22, 2024 11:18 AM

**To:** Denise Baker <[dbaker@constructionsurveyinc.com](mailto:dbaker@constructionsurveyinc.com)>

**Subject:** FW: Ferry Landside Improvement Project

**Importance:** High

Good morning,

Can you please send us a proposal,

Thanks,

**Ahmed Alnajm**

**Safety Manger and Estimator, Bauman Landscape & Construction**



[San Francisco, CA](#) [www.baumanland.com](http://www.baumanland.com)

[\(415\)447-4800](tel:(415)447-4800) [415-447-4800](tel:415-447-4800)

[ahmed@baumanland.com](mailto:ahmed@baumanland.com)

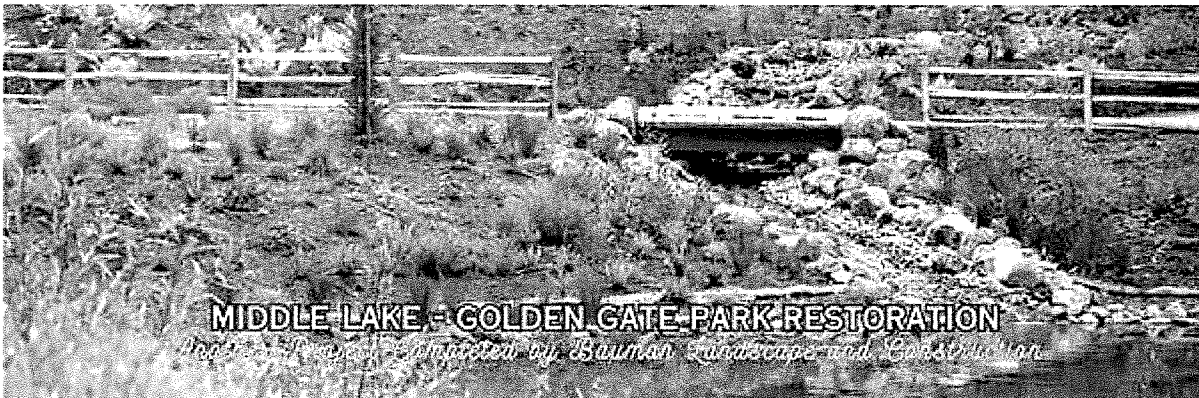

## Angela Bauman

---

**From:** Ahmed Alnajm  
**Sent:** Monday, July 22, 2024 11:58 AM  
**To:** Mike Bauman  
**Cc:** Angela Bauman; Estimating  
**Subject:** FW: Bidding - Ferry Landslide Improvement Project - Sausalito  
**Attachments:** Bauman Landscape SBE Paperwork.pdf

**Ahmed Alnajm**  
Safety Manger and Estimator, Bauman Landscape &  
Construction



---

📍 San Francisco, CA 🌐 [www.baumanland.com](http://www.baumanland.com)

☎ (415)447-4800 📠 415-447-4800

✉ [ahmed@baumanland.com](mailto:ahmed@baumanland.com)

---

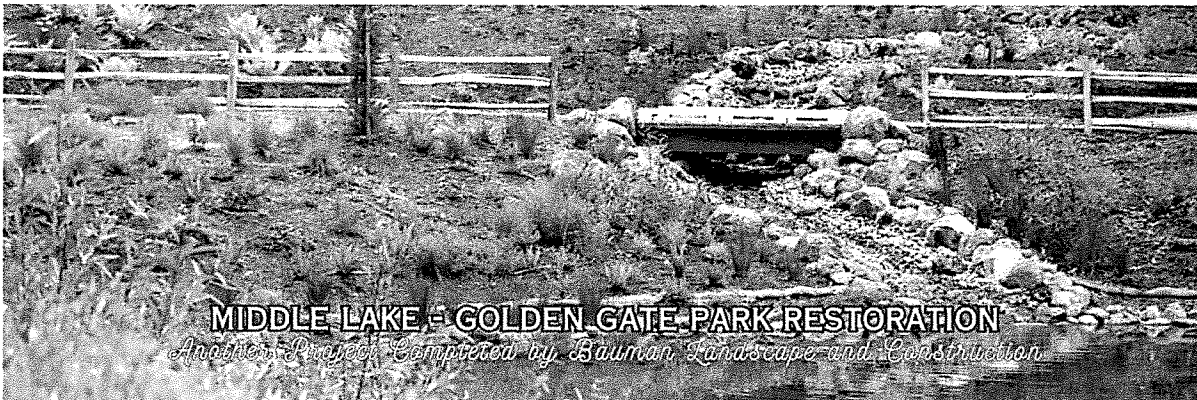

**From:** Katie Holcomb <katieh@mbelectric.com>  
**Sent:** Monday, July 22, 2024 11:49 AM  
**To:** Ahmed Alnajm <ahmed@baumanland.com>; Justin Allred <justina@mbelectric.com>  
**Subject:** RE: Bidding - Ferry Landslide Improvement Project - Sausalito

Hi Ahmed,

MBE is now a certified small business. Please see attached paperwork for today's bid. Justin has sent the bid over already.

Thanks,

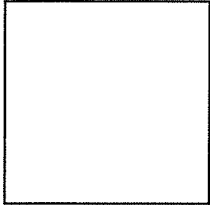
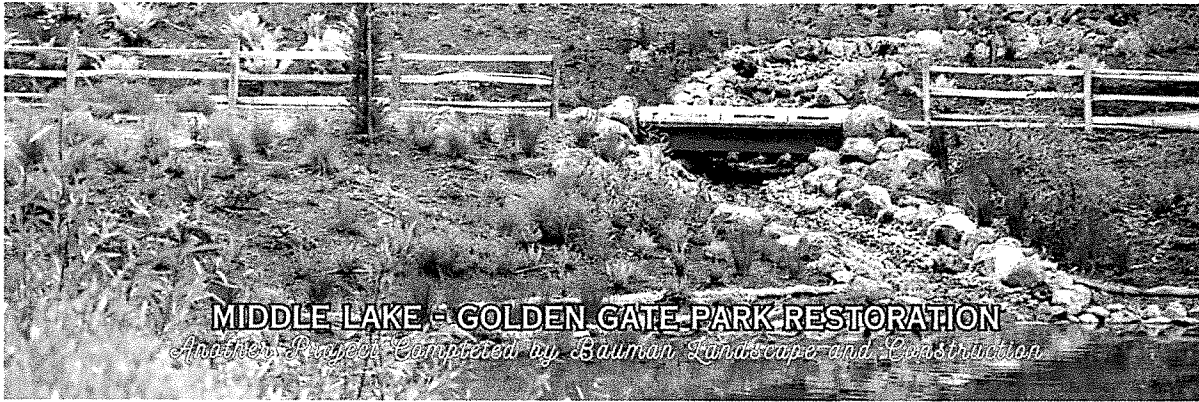

**From:** Ahmed Alnajm  
**Sent:** Friday, July 19, 2024 8:47 AM  
**To:** Katie Holcomb <[katieh@mbelectric.com](mailto:katieh@mbelectric.com)>  
**Subject:** RE: Bidding - Ferry Landslide Improvement Project - Sausalito

Yes we will



Ahmed Alnajm, MS | Estimating, Project Manager  
Bauman Landscape and Construction, Inc.  
2920 Lyon St., San Francisco, California 94123  
P:628.999.8394 Ext:108 C:279.204.3712

**From:** Katie Holcomb <[katieh@mbelectric.com](mailto:katieh@mbelectric.com)>  
**Sent:** Friday, July 19, 2024 6:37 AM  
**Subject:** Bidding - Ferry Landslide Improvement Project - Sausalito

Good Morning

Will you be bidding the above subject project Monday, July 22nd as a General/Prime?

If so please provide the best email to send our quote to and the name of your estimator.

Our estimator is Justin Allred.

Thank you so much for your response.

**Katie Holcomb**  
**Assistant Project Manager – Traffic**  
**Mike Brown Electric Co.** • 561-A Mercantile Drive, Cotati, CA 94931-3040  
**Main Office:** 707-792-8100 • **Direct:** 707-992-1972 • **Cell:** 707-909-0845 • **Fax:** 707-792-8110 • **Email:**  
[katieh@mbelectric.com](mailto:katieh@mbelectric.com)

## Angela Bauman

---

**From:** Daryl Vorne <daryl@abslconstruction.com>  
**Sent:** Friday, July 19, 2024 4:37 PM  
**To:** Daryl Vorne  
**Subject:** Ferry Landside Improvement Project  
**Attachments:** 0722 Sausalito.doc

See attached quote for Monday's bid.

Good luck!

Daryl Vorne  
ABSL Construction  
510-750-4643 cell  
510-727-0900  
510-727-0912 fax

## Angela Bauman

---

**From:** William Delao <billdelao@sbcglobal.net>  
**Sent:** Monday, July 22, 2024 12:14 PM  
**Subject:** FERRY LANDSIDE IMPROVEMENT PROJECT ELECTRIC QUOTE  
**Attachments:** Ferry Landslide Improvement Project\_QUOTE DE.pdf; Affidavit of size to be completed by subs.pdf; Confirmation of Participation to be completed by Subs\_OK.pdf

Good Afternoon,

Attached please find our Electric Quote for the project.  
Good luck on your Bid.

Thanks,

**Delao Electric, Inc.**

617 Moraga Street, San Francisco, CA 94122  
Office (415) 681-7011 Cell (415) 420-3054

G. *Making efforts to assist SBEs in obtaining required bonding, lines of credit, or insurance.*

\_\_\_\_\_  
\_\_\_\_\_  
\_\_\_\_\_

H. *Making efforts to assist SBEs in obtaining necessary equipment, supplies or materials.*

\_\_\_\_\_  
\_\_\_\_\_  
\_\_\_\_\_

I. *Effectively using the services of available minority/women community organizations; contractors groups; and local, state and federal assistance offices.*

List the names of agencies, organizations or groups contacted to provide assistance in contacting, recruiting and using SBEs (**attach copies of requests to agencies, organizations or groups and any responses received, i.e., lists, Internet page download, etc.**).

Names of Agency/Organization/Group	Method/Date of Contact	Results
_____	_____	_____
_____	_____	_____
_____	_____	_____
_____	_____	_____
_____	_____	_____
_____	_____	_____
_____	_____	_____
_____	_____	_____
_____	_____	_____
_____	_____	_____

J. *Describe any other steps that the bidder used to solicit and select its SBEs.*

\_\_\_\_\_  
\_\_\_\_\_  
\_\_\_\_\_

The undersigned certifies that the above narrative description is true and accurate, and may be relied upon by the City of Sausalito in evaluating the bidder's compliance with the solicitation requirements.

\_\_\_\_\_  
Signature of Owner or Authorized Representative      Title      Date

Good Faith Efforts Documentation  
Page 2 of 3

- D. *Providing adequate information about plans, specifications and requirements in a timely manner to SBEs.*

List the names and dates of written notices sent to certified SBEs soliciting sub-bids for this project and the dates and methods used for following up initial solicitations to determine with certainty whether the SBEs were interested (**attach copies of written notices, solicitations, telephone records, fax confirmations, etc.**)

Names of SBEs Solicited	Date of Initial Solicitation	Follow Up Methods and Dates

- E. *Negotiating in good faith with SBEs.*

- F. *Not Rejecting SBEs as an unqualified firm without sound business reasons.*

List names of rejected SBEs and the reasons for the bidder's rejection of the SBEs and the firms selected for that work (attach copies of quotes from the firms involved):

Names of Rejected SBEs	Reasons for Rejection	Names of Selected Firms

# DBE/SBE CONFIRMATION OF PARTICIPATION IN CONTRACT

This form is to be completed by each DBE/SBE owner whose sub-bid was accepted. Please make additional copies of form as necessary.

As a condition to the award of Contract No. 03.01.001, Ferry Landside Improvement Project

*Contract # and Name*

I, Angela Baumann, do hereby confirm that  
*Name of DBE/SBE Owner*

Baumann Landscape & Const. will be  
*Name of DBE/SBE Firm*

performing/providing the following services:

General contractor

The above services will be provided to Baumann  
*Name of Prime Contractor*

for the agreed upon dollar amount of \$ \_\_\_\_\_.

I declare under penalty of perjury that the foregoing statement is accurate and true.

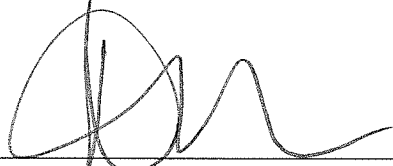
  
Signature

7/22/24  
Date



**City of Sausalito**

**Prime Contractor and Subcontractor/Subconsultant/Supplier Report**

Bidder's Name: Bauman Landscape Const. Inc. contract # and Name: 03.01.001 and Ferry Landside Improvement Project

Address: 2220 W. 8th St. SF Zip Code: 94131 Is your firm a Disadvantaged Business Enterprise: (CBE) Yes No X

Owner or Contact Person: Angela Bauman Phone: 415 447 4802 Fax: (CBE) Yes

E-Mail: angel@baumanland.com Ethnicity: W Gender: F Annual Gross Receipts: \$10M Age of Firm: 45

**INSTRUCTIONS:** Please provide information on ALL firms (subcontractors/subconsultants/suppliers) that provided Bidder a bid, quote, or proposal to perform work, provide labor, render services or provide supplies in connection with this contract **WHETHER BID WAS ACCEPTED OR NOT**. You shall provide this information for all sub-bidders regardless of tier for both DBEs and non-DBEs alike. Include all bid acceptance(s) AND rejection(s). If no subcontractors/subconsultants/suppliers will be used, mark "N/A" and sign the form.

Provide the North American Industry Classification System (NAICS) code(s) applicable to each scope of work the firm is sought out to perform on the contract. NAICS search <https://www.census.gov/naics/>.

Ethnicity: Indicate whether the majority owner is (AS) Asian-Pacific; (B) Black; (H) Hispanic; (N) Native; (SA) Subcontinent Asian; (NM) Non-Minority, or (O) Other  
 Gender: Indicate gender for the majority owner, either (M) Male or (F) Female. Make a copy of this form for additional firms.

**Signature is required on page two of this form to be deemed responsive.**

Subcontractor/Subconsultant/Supplier Firm Name/Address/Contact Information	Contractor's License No. DIR Registration No.	DBE/SBE (Yes*/No)	Portion of Work or Type of Materials/Supplies (DBE suppliers must complete the DBE Supplier Form)	NAICS Code(s) for each work item	Dollar Amount of Work Materials/Supplies	Bid/Quote Accepted (Yes**/No)	DBE/SBE Amount***	Annual Gross Receipts
1 Name: <u>STRIPPYGRAPHIC</u> Address: <u>501 Pacheco St. Cotati</u> Zip Code: <u>94926</u> Contact Person: <u>quida</u> E-mail: <u>quidastrippygraphic</u> Phone: <u>707 739 9925</u> Ethnicity: <u>F</u> Gender: <u>M</u>	<u>10700-0495</u>	<u>ND</u>	<u>stripping</u>		<u>\$1,570</u>	<u>YES</u>	<u>ND</u>	< \$1 Million < \$5 Million < \$10 Million < \$15 Million + Age of Firm: <u>40</u>
2 Name: <u>CHRISTY PLUMBING &amp; ELECTRICAL</u> Address: <u>1 N. RANCHO CT. ELSHAWAY</u> Zip Code: <u>94803</u> Contact Person: <u>CHRIS</u> E-mail: <u>CHRIS@STEELEINC.COM</u> Phone: <u>754 9426</u> Ethnicity: <u>M</u> Gender: <u>M</u>	<u>10700-75426</u>	<u>ND</u>	<u>Electrical</u>		<u>\$83,145</u>	<u>YES</u>	<u>ND</u>	< \$1 Million < \$5 Million < \$10 Million < \$15 Million + Age of Firm: <u>5</u>
3 Name: <u>CHRIS P. 18</u> Address: <u>4730 S D 053004</u> Zip Code: <u>10700-3506</u> Contact Person: E-mail: Phone: Ethnicity:	<u>10700-3506</u>	<u>ND</u>	<u>stripping</u>		<u>96,680</u>	<u>NO</u>	<u>ND</u>	< \$1 Million < \$5 Million < \$10 Million < \$15 Million + Age of Firm: <u>50</u>



Prime Contractor and Subcontractor/Subconsultant/Supplier Report (Continued)

Subcontractor/Subconsultant/Supplier Firm Name/Address/Contact Information	Contractor's License No. DIR Registration No.	DBE/SBE (Yes*/No)	Portion of Work or Type of Materials/Supplies (DBE suppliers must complete the DBE Supplier Form)	NAICS Code(s) for each work item	Dollar Amount of Work Materials/Supplies	Bid/Quote Accepted (Yes***/No)	DBE/SBE Amount***	Annual Gross Receipts
Name: <u>DELIA ERECHUE</u> Address: <u>117 MORRA</u> Zip Code: <u>32823 3588</u> Contact Person: <u>BILL DELIA</u> E-mail: <u>bill@deliaconstruction.com</u> Phone: <u>415 481 704</u> Ethnicity: <u>W</u> Gender: <u>NY</u>	<u>10000-</u>	<u>Yes</u>	<u>1753941</u>		<u>133,171</u>	<u>NO</u>	<u>13317</u>	<input type="checkbox"/> < \$1 Million <input type="checkbox"/> < \$5 Million <input type="checkbox"/> < \$10 Million <input type="checkbox"/> < \$15 Million +
Name: <u>PAULMANT REIDLE</u> Address: <u>10240 SANSALITO</u> Zip Code: <u>94961</u> Contact Person: _____ E-mail: _____ Phone: _____ Ethnicity: _____ Gender: _____	<u>10003305</u>	<u>NO</u>			<u>\$10K</u>	<u>NO</u>		<input type="checkbox"/> < \$1 Million <input type="checkbox"/> < \$5 Million <input type="checkbox"/> < \$10 Million <input type="checkbox"/> < \$15 Million +
Name: <u>MIKE BROWN</u> Address: <u>511 MORGANTHALE</u> Zip Code: <u>94961</u> Contact Person: <u>JUSTIN ATTARD</u> E-mail: _____ Phone: _____ Ethnicity: _____ Gender: _____	<u>10000</u>	<u>NO</u>			<u>213,303</u>	<u>NO</u>		<input type="checkbox"/> < \$1 Million <input type="checkbox"/> < \$5 Million <input type="checkbox"/> < \$10 Million <input type="checkbox"/> < \$15 Million +

Attach additional sheets as necessary.

DBE/SBE Amount: \$900,000 = 3 % Bidder's DBE/SBE Achievement  
 Total Bid Amount: \$ \_\_\_\_\_

\* If Yes, please also provide certification number or California Unified Certification Program Firm ID number.

\*\* Do not indicate more than one "Yes" for alternative subcontractors for the same work. Do not indicate TBD for "Bid Quote Accepted."



\*\*\* DBE participation includes that portion of the work actually performed by a certified DBE with its own forces. The DBE Regular Dealer/Distributor Affirmation Form must be submitted to confirm counting determinations for DBE supplier/distributor credit. Count 60% of the cost of materials and supplies or 40% for DBE distributor.

The undersigned agrees that if it is the successful bidder and is awarded the contract with City of Sausalito, it will enter into a formal agreement with the subcontractor(s), subconsultant(s) and/or supplier(s) whose bid/quote was accepted for the work as indicated above. I certify that the information included on this form is accurate and true.

Signature of Owner or Authorized Representative

Title

Date

  7/25/24

Fremont Office  
 43650 Osgood Road  
 Fremont, CA. 94539  
 Phone: (510) 656-2840  
 Fax: (510) 656-2397



CL No. 374600  
 DIR No. 100000306  
 A General Engineering  
 C-13 Fence, Wire, Wood  
 C-32 Highway Improvement  
 Union Contractor / No Minority Status  
 Bond Rate 1.2%

<b>To:</b>	Bauman Construction	<b>Contact:</b>	Ahmed Alnajm
<b>Address:</b>	1255 Battery Street, Suite 400 San Francisco, CA 94111 SAN FRANCISCO	<b>Phone:</b>	(415) 447-4800
		<b>Fax:</b>	(415) 447-4258
<b>Project Name:</b>	Ferry Landside Improvement PN 03.01.001	<b>Bid Number:</b>	66355
<b>Project Location:</b>	Marin County, Sausalito	<b>Bid Date:</b>	7/22/2024
<b>Addendum #:</b>	1,2,3		

Item #	Item Description	Estimated Quantity	Unit	Unit Price	Total Price
<b>A BASE BID</b>					
No Item 1	Remove Pavement Markings And Stripe By Grinding As Per Note 6 On The Demolition Plan	1.00	LS	\$10,000.00	\$10,000.00
01	PARTIAL ITEM: Mobilization For Chrisp Company Work Only	1.00	LS	\$10,000.00	\$10,000.00
02	PARTIAL ITEM: Traffic Control For Chrisp Company Work Only	1.00	LS	\$25,000.00	\$25,000.00
13	4-INCH THERMOPLASTIC STRIPING	250.00	LF	\$10.00	\$2,500.00
14	6-INCH THERMOPLASTIC STRIPING	340.00	LF	\$12.00	\$4,080.00
15	CONTINENTAL CROSSWALK	2,285.00	SF	\$14.00	\$31,990.00
16	PAVEMENT MARKINGS	15.00	EACH	\$80.00	\$1,200.00
17	STRIPING PARKING STALL NUMBER	7.00	EACH	\$120.00	\$840.00
18	REINSTALL EXISTING SIGN ON NEW POLE	16.00	EACH	\$395.00	\$6,320.00
19	NEW SIGN ON NEW POLE	10.00	EACH	\$495.00	\$4,950.00
<b>Total Price for above A BASE BID Items:</b>					<b>\$96,880.00</b>
<b>B BID ALTERNATE 1</b>					
08	REINSTALL EXISTING SIGN ON NEW POLE	2.00	EACH	\$395.00	\$790.00
<b>Total Price for above B BID ALTERNATE 1 Items:</b>					<b>\$790.00</b>
<b>D BID ALTERNATE 4</b>					
09	NEW SIGN ON NEW POLE (DEDUCT)	2.00	EACH	(\$495.00)	(\$990.00)
<b>Total Price for above D BID ALTERNATE 4 Items:</b>					<b>(\$990.00)</b>
<b>Total Bid Price:</b>					<b>\$96,680.00</b>

**Notes:**

- EXCLUDE: Removal of Temporary Delineation
- EXCLUDE: Installation of Temporary Delineation After Paving/Resurfacing/Road Grinding or Planing
- INCLUDED: Temporary Delineation After Stripe Removal
- EXCLUDE: Seal Coat
- Contractor is to Provide Stockpile Location for Striping Removal Debris.
- This quotation excludes performing removal work while other operations are in progress on jobsite.
- This quotation excludes the removal & disposal of hazardous grindings & spoils from jobsite.
- Prime contractor to provide disposal area & dispose of all Non-hazardous stripe & marker debris. Disposal area to be on jobsite.
- General Contractor to Provide Clean Water Source At No Cost to Chrisp Company. Must be Located On Jobsite.
- EXCLUDE: Lead Compliance Plan
- This quotation EXCLUDES removal of Yellow stripe and markings treated as hazardous.



Fremont Office  
 43650 Osgood Road  
 Fremont, CA. 94539  
 Phone: (510) 656-2840  
 Fax: (510) 656-2397



CL No. 374600  
 DIR No. 1000000306  
 A General Engineering  
 C-13 Fence, Wire, Wood  
 C-32 Highway Improvement  
 Union Contractor / No Minority Status  
 Bond Rate 1.2%

<b>To:</b>	Bauman Construction	<b>Contact:</b>	Ahmed Alnajm
<b>Address:</b>	1255 Battery Street, Suite 400 San Francisco, CA 94111 SAN FRANCISCO	<b>Phone:</b>	(415) 447-4800
		<b>Fax:</b>	(415) 447-4258
<b>Project Name:</b>	Ferry Landside Improvement PN 03.01.001	<b>Bid Number:</b>	66355
<b>Project Location:</b>	Marin County, Sausalito	<b>Bid Date:</b>	7/22/2024
<b>Addendum #:</b>	1,2,3		

- EXCLUDE: Concrete Coring for Signs
- EXCLUDE: Furnishing and Installation of Mast Arm Signs
- If Chrisp Co. is required to DIG BY HAND due to issues U.S.A., etc. an additional \$20.00 per hole will be charged
- EXCLUDE: Monument Signs
- EXCLUDE: ALL Signs on Traffic Signal Plans
- EXCLUDE: Pedestrian Barricades
- EXCLUDE: ALL Solar Powered LED Signs to be Done By Others
- EXCLUDE: ALL HARD WIRED ELECTRICAL SIGNS
- EXCLUDE: Removal of Concrete Curing Material and or Surface Prep prior to PAINT / THERMOPLASTIC / PAVEMENT MARKER Striping on Concrete Surfaces. Typical Surface Prep Methods on Concrete (Water Blasting, Sand Blasting, Shot Blasting, Bead Blasting)
- All night lights required are to be supplied by general contractor
- This quotation excludes installing permanent striping while other operations are in progress on jobsite.
- Chrisp Co. will remove contractors short term temporary markers (Floppies) placed for lanelines and centerlines only (no edgelines or shoulders). No Tape removal. Short Term Temporary markers are to be placed so that striping may be placed before removal of temporary markers.
- This quotation Excludes furnishing or placing ALL signage for advance posting of ramp closures / detours for our operations.
- This quotation Excludes furnishing or placing ALL detour signage for our operations.
- EXCLUDE: Encroachment Permit (If required to be provided at No Cost to Chrisp Company)
- EXCLUDE: ALL Etching, Inscribing on curb,
- Mobilization & Traffic Control Items shall not be adjusted for decreases in the work.
- Mobilization & Traffic Control Items shall be adjusted for increases in the work
- Access / and or Accessibility by 1 Ton Vehicle required for Chrisp Company work
- EXCLUDE: Maintenance of temporary delineation ie. temporary paint, temporary tape, channelizers, etc...
- EXCLUDE: Red-Lined As-Built Drawings
- EXCLUDE: Truncated Domes
- EXCLUDE: Construction Area Signs
- EXCLUDES: Decorative Pavement/Concrete Overlay, Decorative Stamped Asphalt/Concrete and Preform Thermo Stripe and Legends

Fremont Office  
 43650 Osgood Road  
 Fremont, CA. 94539  
 Phone: (510) 656-2840  
 Fax: (510) 656-2397



CL No. 374600  
 DIR No. 100000306  
 A General Engineering  
 C-13 Fence, Wire, Wood  
 C-32 Highway Improvement  
 Union Contractor / No Minority Status  
 Bond Rate 1.2%

<b>To:</b>	Bauman Construction	<b>Contact:</b>	Ahmed Alnajm
<b>Address:</b>	1255 Battery Street, Suite 400 San Francisco, CA 94111 SAN FRANCISCO	<b>Phone:</b>	(415) 447-4800
		<b>Fax:</b>	(415) 447-4258
<b>Project Name:</b>	Ferry Landside Improvement PN 03.01.001	<b>Bid Number:</b>	66355
<b>Project Location:</b>	Marin County, Sausalito	<b>Bid Date:</b>	7/22/2024
<b>Addendum #:</b>	1,2,3		

- NO RETENTION TO BE TAKEN ON CONTRACTS LESS THAN \$5,000.00
- **1 Move- In(s) included. Additional Move- Ins \$4,500.00**
- Chrisp Company reserves the right to withdraw proposal if written acceptance is not received within 30 days of bid date
- Clean, clear and unobstructed access required for Chrisp Co. work
- Final PAY QTYs presented by owner MUST be agreed by Chrisp Co.
- After receiving contract 10 working days written notice required prior to scheduling of work
- EXCLUDE: Special Insurance Requirements, (i.e. Railroad Insurance, \_\_\_\_\_)
- This quotation excludes Primary Liability Insurance greater than \$2,000,000.
- This quotation excludes all work associated with the project SWPP and WPCP.
- ALL Bid items shall NOT be adjusted or removed without written / or verbal permission.
- Retainage percentage on monthly progress payments to be no greater than the percentage retained by the Owner on its payment to the Contractor. If Owner reduces the retainage percentages on payments to the Contractor, the Contractor shall likewise reduce the retainage percentage on payment to Chrisp Company. Full retention to be released no later than thirty, (30) Days after completion of Chrisp Companies work. Excessive or delinquent retainage will be subject to the highest interest rate allowed by law.
- Chrisp Company shall be reimbursed the full amount for bonds upon submission to General Contractor. Retention shall not be held from bond reimbursement.
- THIS QUOTATION IS BASED ON A STANDARD MONDAY THROUGH FRIDAY WORK WEEK. ADDITIONAL COSTS WILL OCCUR FOR WORK PERFORMED ON WEEKENDS
- CHRISP COMPANY WILL USE EXISTING EMPLOYEE POOL TO PERFORM ALL WORK ON THIS PROJECT. IF THERE ARE ANY HIRING GOALS FOR THIS PROJECT THIS WILL BE EXCLUDED
- EXCLUDE: ALL Safety Training, Badging, Drug Testing and Orientation (To be paid at time and material Cal-Trans
- EXCLUDE: REMOVAL OF USA MARKINGS
- EXCLUDE Automated Flagger Assistance Device. General Contractor to provide automated flagger assistance device (if required) at no cost.
- General Contractor Shall Disclose and Update Chrisp Company on all project Milestone bonuses, Chrisp Company shall be awarded a percentage of Milestone bonus in proportion to Chrisp Company percentage of contract work to meet Milestone Deadlines.
- EXCLUDE: Advanced posting of "No Parking" signs
- All work not specifically described in bid items is excluded

<p><b>ACCEPTED:</b>          The above prices, specifications and conditions are satisfactory and are hereby accepted.</p> <p><b>Buyer:</b> _____</p> <p><b>Signature:</b> _____</p> <p><b>Date of Acceptance:</b> _____</p>	<p><b>CONFIRMED:</b>  <b>Chrisp Company</b></p> <p><b>Authorized Signature:</b> _____</p> <p><b>Estimator:</b> Danny Azcueta          650-2241115 dazcueta@chrispco.com</p>
--	---



**DELAO ELECTRIC INC.**

CONTRACTOR LIC # 328973  
(FED ID #27-1240112)

617 MORAGA STREET  
SAN FRANCISCO, CA 94122  
Phone: (415) 681-7011  
Fax: (415) 681-7522  
Email: [billdelao@sbcglobal.net](mailto:billdelao@sbcglobal.net)

MBE/LBE/HRC CERT#112410278 SF BUSINESS REG. TAX#193194 DBE/SB CALIFORNIA CERT#1753941 D.I.R.CERT. #100003588

**BID DATE:** 07/22/2024

**PROJECT:** Ferry Landside Improv. Project

**TO:** All General Contractors

We are pleased to offer a quote on the electrical scope of work on the above project based on the following bid documents:

- Electrical Bid Plans & Specs Only
- Addenda #01, #02 & #03.

**Electrical Base Bid:** **\$ 78,290.00**  
**Bid Item #34**  
**(Drawings E0.1/E1.0/E2.0/E3.0/E3.1)**

**Electrical Alternate #3:** **\$ 54,881.00**  
**(Drawings E1.1)**

**Total Electrical Bid (Base +Alt #3):** **\$ 133,171.00**

**WE INCLUDE:**

**-Base Bid (Bid Item #34):**

- (1) 4'x6' Underground Manhole
- (2) 12"x22.25" Underground Handholes
- (2) N09 Underground Pull Boxes
- F/I Conduits and Pull rope only. (Per Conduit Schedule on E1.0)
- Electrical Permit & Inspections.

**- Alternate #3:**

- Conduit and wire for Lighted Bollards
- F/I Lighted Bollards (excluding Foundations)
- F/I Breaker at Panel A
- F/I Multi-Relay Time Clock
- Underground N09 Pull Box
- Lighting Acceptance Testing

**WE EXCLUDE (If Any u.o.n in Include Section above):**

- Any Wire/Cablings for Conduits on Drawing E1.0 (NOT SPECIFY ON DRAWINGS)
- Excavating, Trenching, Drilling, Shoring, Sand, bedding, Gravel, Compacting, and Backfill.
- Concrete Duct Bank Work and all associated (Trenching/Concrete/Rebar/Backfill).
- Bollard Pole Foundation. (Drilling/Concrete/rebar)
- Any Irrigation Connections/Controllers conduits/wiring not shown on Electrical plans
- Removal and Reinstall of Existing Self-Service Solar Pay Stations.
- Locating any underground utilities, Site Temp Lighting/Power, Traffic Control, Street closure permits
- Demo of any Existing Underground Raceways & Any Electrical Below Surface.
- Furnish, Install & Repair Any Work, Equipment, or Devices not Drawn on Electrical Bid Plans.
- Buy America Products, Mock Up Items, Equipment Signs, Lighting Spares & Any Other Spares, & Maintenance Tools
- O/T & D/T, After Hours, Sat, Sun & Holiday Work. Provide Payment & Performance Bonds
- PG&E Work & Coordination, Other Permits & City's Fees
- Painting on Conduit, Junction Boxes & Incidental Hardware
- Asphalt, concrete work, concrete pads, saw cutting, coring, rebar, X-Ray
- Any Restoration of any surfaces requiring patching, plastering, painting and/or other repair due to any new/demo Elec. work
- Removal & Disposal of any Inside/Outside Concrete & Hazardous material, Debris, or Trash from jobsite.

Please call should you have any questions on this bid at (415) 420-3054. Good Luck on your bid.

**DELAO ELECTRIC INC.**

### SMALL BUSINESS ENTERPRISE AFFIDAVIT OF SIZE

**Who should submit this form:**

If your business was certified by any of the following, please complete and submit this form with a copy of your Certification. This form may be used for Prime Contractors, Subcontractors, Subconsultants, and Suppliers. Your firm's average annual gross receipts must fall below the U.S. Small Business Administration (SBA) industry-specific size cap and in no case exceed \$30.72 million. (View SBA size table here: <https://www.sba.gov/content/table-small-business-size-standards> and click on size standards table link at bottom of web page.)

- SMBE/SWBE Certification by state other than California.
- SB/MICRO/SB-PW Certification by the California Department of General Services (DGS).
- SBA 8(a) Certification by the Small Business Administration.
- SBE/MBE/WBE Certification by other California county or local government-certifying agency or out-of-state government-certifying agency that conform with CITY OF SAUSALITO requirements.

See Special Provisions S11.02, SBE Eligibility, subsections A.1.a. and A.1.b., for further information on business size, and subsection B for list of all acceptable certifications.

I HEREBY DECLARE AND AFFIRM that I am the **PRESIDENT**

(Title)

and duly authorized representative of **DELAO ELECTRIC INC**  
(Name of Firm)

whose address is **617 MORAGA ST., SAN FRANCISCO, CA 94122**

and whose phone is **415-681-7011**

I HEREBY DECLARE AND AFFIRM that the firm is a Small Business Enterprise (SBE) in accordance with CITY OF SAUSALITO (CITY OF SAUSALITO) standards as defined in its Diversity Program for Contracts. The firm is certified as of the date that the CITY OF SAUSALITO receives the bid/proposal for **Contract No. 0301001-000, FERRY LANDSIDE IMPROVEMENT PROJECT.**

**I will provide the certification to document this fact with this enclosure.**

I DO SOLEMNLY DECLARE AND AFFIRM UNDER THE PENALTIES OF PERJURY THAT THE CONTENTS OF THE FOREGOING STATEMENTS ARE TRUE AND CORRECT, AND THAT I AM AUTHORIZED, ON BEHALF OF THE ABOVE FIRM, TO MAKE THIS AFFIDAVIT.

**07/22/2024**

(Date)

**WILLIAM DELAO**

(Affiant)

**PRESIDENT**

(Title)

## DBE/SBE CONFIRMATION OF PARTICIPATION IN CONTRACT

This form is to be completed by each DBE/SBE owner whose sub-bid was accepted. Please make additional copies of form as necessary.

As a condition to the award of Contract No. 03.01.001, Ferry Landside Improvement Project  
*Contract # and Name*

I, WILLIAM DELAO, do hereby confirm that  
*Name of DBE/SBE Owner*

DELAO ELECTRIC INC. will be  
*Name of DBE/SBE Firm*

performing/providing the following services:

ELECTRICAL SCOPE OF WORK PER PROJECT ELECTRICAL DRAWINGS

The above services will be provided to \_\_\_\_\_  
*Name of Prime Contractor*

for the agreed upon dollar amount of \$ 133,171.00.

I declare under penalty of perjury that the foregoing statement is accurate and true.

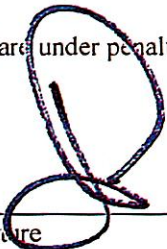
  
\_\_\_\_\_  
Signature

07/22/24  
\_\_\_\_\_  
Date





• **STANDARD TERMS & CONDITIONS**

- Shift Rate work to be excluded from retention withholdings unless otherwise agreed upon.
- This Quote including pricing & all conditions to be included in any subcontract or work order agreement (Contract) from the customer.
- **Customer responsible for all maintenance and protection of PRS work after completion.**
- Indemnity: Any indemnity and defense obligation required from PRS shall be proportional and limited to the extent of PRS's acts, omissions, fault or negligence contribute to any alleged or actual claims for damages.
- Insurance: Commercial Liability \$2MM per occurrence, \$4MM Aggregate, \$4MM Products & Completed Operations Aggregate, \$2MM Personal and Advertising Injury, \$2MM Commercial Auto, Worker's Comp coverage per statute. All WRAP/OCIP projects are NOT included in our insurance program. Contractor is responsible for giving PRS advance notice and adequate time to enroll in any WRAP/OCIP program prior to doing the work. Fees for WRAP/OCIP enrollment to be covered by the contractor.
- California prompt pay statutes shall be enforced.
- **Quote valid for award within 90 days and for work performed through June 30th, 2025.** Pricing adjustments/escalation may apply outside these time frames.

**DISPATCH NOTE:** PRS looks forward to working with your team! For scheduling, please call 916-685-2204 or email us at [DispatchNorth@pavementrecycling.com](mailto:DispatchNorth@pavementrecycling.com)

**Payment Terms**

95% Monthly Progress Estimate and Retention Withhold as permitted by Contract and State Law.

Notice "Under the Mechanics Lien Law (California Code of Civil Procedure, Section 1181 et seq.), any contractor, subcontractor, laborer, supplier or other person who helps to improve your property but is not paid for his work or supplies, has a right to enforce a claim against your property. This means that after a court hearing, your property could be sold by a court officer and the proceeds of the sale used to satisfy the indebtedness. This can happen even if you have paid your own contractor in full, if the subcontractor, laborer or supplier remains unpaid."

Date:

Accepted By:

---

Page 2 of 2

From: Daryl Pollak

# Striping Graphics

501 Aaron St. Cotati, CA. 94931

Phone (707) 793-9425

Fax (707) 793-9760

Date: 7/22/2024

C-32 State Contractors License # 576-756 exp. 9/30/25

D.I.R. #1000006495

JOB: Ferry Landside Impr.

Tax ID #680144410

City, Sausalito, CA.

TO: Estimator

Company: \_\_\_\_\_

Phone # \_\_\_\_\_

Fax # \_\_\_\_\_

Plan Sheet C's

Spec Sec. 32 17 23

Dated 7/9/24

Addendum 1,2,3

Item #	Description	Quantity	UNIT	TOTAL
	Mobilization(s) Phase 1 & 2	2 ea	L.S.	\$10,000.00
13	4-inch Thermoplastic Striping	250 lf	15.00	\$3,750.00
14	6-inch Thermoplastic Striping	340 lf	9.00	\$3,060.00
15	Continental Crosswalk	2285 sf	10.00	\$22,850.00
16	Pavement Markings	15 ea	450.00	\$6,750.00
17	Striping Parking Stall Number	7 ea	100.00	\$700.00
	Striping Removal (by grinding) <i>No pavement repair.</i>	as shown	L.S.	\$30,000.00
	Concrete Wheel Stop (36" long, paint blue)	7 ea	100.00	\$700.00
	Yellow & Red Painted Curb (w/ stenciling)	470 lf	8.00	\$3,760.00
<u>Excludes:</u> Temporary Striping Cleaning of Streets, Sweeping Certified Flaggers Written Traffic Control Plan Staking, Surveying, Message Board Surfacing, Seal Coat, Posting N/P Mast Arm Signage / Night Work				
			<b>Total</b>	<b>\$81,570.00</b>

**Proposal & Contract Requirements:**

- 3 week Look Ahead Schedule
- Proposal void after 60 days
- Modifications must be agreed upon.
- 48 hr. sch. cancellation notice

Estimator: [guido@stripinggraphics.com](mailto:guido@stripinggraphics.com)

- Notes: 1) Labor Union Signatory
- 2) One Year Warranty
- 3) Quote valid for 90 days
- 4) Cost Escalations after 90 Days
- 5) Three week schedule required

Signature \_\_\_\_\_

Date \_\_\_\_\_

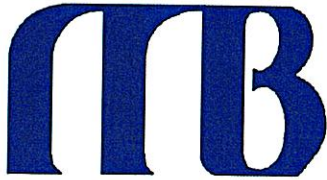

**Mike Brown Electric Co.**

*An Employee Owned Company*

561-A Mercantile Drive

Cotati, CA 94931-3040

(707) 792-8100 - Fax (707) 792-8110

Cont. Lic. #306767 ~ D.I.R. #1000000469

**PROJECT:** Ferry Landside Improvement Project

**LOCATION:** Sausalito

**BID DATE:** 7/22/2024

**To:** General Contractor

**From:** Justin Allred

**THE FOLLOWING IS OUR BID FOR THE ABOVE-REFERENCED PROJECT**

Bid Item	Description	Quantity	Unit Price	Total
33	Electrical Manhole	1	EA	\$ 125,175.00
Add Alt #3				
1	Lighted Bollards	16	\$5,100.00	\$ 88,128.00
<b>Grand Total:</b>				<b>213,303.00</b>

**Note:** 1. Bid Based on Monthly Progress Payments with Final Payment (including retention) due 30 days after completion of our work.

**Addenda's Noted:** 1, 2, 3

- Excludes**
- 1) Layout/Staking
  - 2) Permits/Fees including Caltrans and PG&E
  - 3) Bond
  - 4) Traffic Control Plans
  - 5) Hazardous Material Removal
  - 6) Spoils off Haul
  - 7) Asphalt Grinding or Patch Back
  - 8) Sidewalk Removal or replacement
  - 9) Landscape or surface restoration

## Ahmed Alnajm

---

**From:** Chris Trummell <chris@ct-electric.com>  
**Sent:** Monday, July 22, 2024 12:23 PM  
**To:** Ahmed Alnajm  
**Subject:** Re: Document1.pdf

\$83,145 for fixtures and labor. Fixture package is \$60k

Bauman install conduit, trenching and concrete  
Bauman provide all wire

Chris Trummell (415) 819-7660  
CT Electric  
1 N Rancho Ct  
El Sobrante, CA 94803  
Lic. 1035694  
[www.ct-electric.com](http://www.ct-electric.com)

On Wed, Jul 17, 2024, 9:55 AM Ahmed Alnajm <[ahmed@baumanland.com](mailto:ahmed@baumanland.com)> wrote:

Chris,

Follow this revised plan,

Thanks,

**From:** Ahmed Alnajm  
**Sent:** Wednesday, July 17, 2024 9:29 AM  
**To:** [chris@ct-electric.com](mailto:chris@ct-electric.com)  
**Subject:** Document1.pdf  
**Importance:** High

Hi Chris,

Can you please send me a proposal for the electrical,

Get the price for the Bollard from Bega there is 16 EA with out light and on alternative 3 the will change the standard bollard to light bollards,,





**INSTRUCTIONS – FINAL REPORT-UTILIZATION OF DISADVANTAGED BUSINESS ENTERPRISES  
(DBE) AND FIRST-TIER SUBCONTRACTORS**

1. **Local Agency Contract Number** - Enter the Local Agency contract number or identifier.
2. **Federal-Aid Project Number** - Enter the Federal-Aid Project Number.
3. **Local Agency** - Enter the name of the local or regional agency that is funding the contract.
4. **Contract Acceptance Date** - Enter the date the contract was accepted by the Local Agency.
5. **Contractor/Consultant** - Enter the contractor/consultant's firm name.
6. **Business Address** - Enter the contractor/consultant's business address.
7. **Final Contract Amount** - Enter the total final amount for the contract.
8. **Contract Item Number** - Enter contract item for work, services, or materials supplied provided. Not applicable for consultant contracts.
9. **Description of Work, Services, or Materials Supplied** - Enter description of work, services, or materials provided. Indicate all work to be performed by DBEs including work performed by the prime contractor/consultant's own forces, if the prime is a DBE. If 100% of the item is not to be performed or furnished by the DBE, describe the exact portion to be performed or furnished by the DBE. See LAPM Chapter 9 to determine how to count the participation of DBE firms.
10. **Company Name and Business Address** - Enter the name, address, and phone number of all subcontracted contractors/consultants. Also, enter the prime contractor/consultant's name and phone number, if the prime is a DBE.
11. **DBE Certification Number** - Enter the DBE's Certification Identification Number. Leave blank if subcontractor is not a DBE.
12. **Contract Payments** - Enter the subcontracted dollar amount of the work performed or service provided. Include the prime contractor/consultant if the prime is a DBE. If the materials or supplies are obtained from a DBE manufacturer, count 100% of the cost of the materials or supplies toward DBE goals. If the materials or supplies are purchased from a DBE regular dealer/supplier, count 60% of the cost of the materials or supplies toward DBE goals. The Non-DBE column is used to enter the dollar value of work performed by firms that are not certified DBE or for work after a DBE becomes decertified.
13. **Date Work Completed** - Enter the date the subcontractor/subconsultant's item work was completed.
14. **Date of Final Payment** - Enter the date when the prime contractor/consultant made the final payment to the subcontractor/subconsultant for the portion of work listed as being completed.
15. **Original DBE Commitment Amount** - Enter the "Total Claimed DBE Participation Dollars" from ~~ES&G~~ bid s 10-O2 for the contract.
16. **Total** - Enter the sum of the "Contract Payments" Non-DBE and DBE columns.
17. **Contractor/Consultant Representative's Signature** - The person completing the form on behalf of the contractor/consultant's firm must sign their name.
18. **Contractor/Consultant Representative's Name** - Enter the name of the person preparing and signing the form.
19. **Phone** - Enter the area code and telephone number of the person signing the form.
20. **Date** - Enter the date the form is signed by the contractor's preparer.
21. **Local Agency Representative's Signature** - A Local Agency Representative must sign their name to certify that the contracting records and on-site performance of the DBE(s) has been monitored.
22. **Local Agency Representative's Name** - Enter the name of the Local Agency Representative signing the form.
23. **Phone** - Enter the area code and telephone number of the person signing the form.
24. **Date** - Enter the date the form is signed by the Local Agency Representative.



CITY OF SAUSALITO  
**MONTHLY SBE TRACKING VERIFICATION**  
*To be filled out w/ Billing Submission*

CONTRACT NO.:		MONTH:					YEAR:
Truck Owner	SBE Cert. No.	Company Name and Address	Truck No.	California Hwy. Patrol CA No.	Commission or Amount Paid*	Date Paid	Lease Arrangement (X if applicable)
					\$		Lease Agreement with Non-SBE with SBE <input type="checkbox"/>
					\$		Lease Agreement with Non-SBE with SBE <input type="checkbox"/>
					\$		Lease Agreement with Non-SBE with SBE <input type="checkbox"/>
					\$		Lease Agreement with Non-SBE with SBE <input type="checkbox"/>
					\$		Lease Agreement with Non-SBE with SBE <input type="checkbox"/>
					\$		Lease Agreement with Non-SBE with SBE <input type="checkbox"/>
					\$		Lease Agreement with Non-SBE with SBE <input type="checkbox"/>
					\$		Lease Agreement with Non-SBE with SBE <input type="checkbox"/>
					\$		Lease Agreement with Non-SBE with SBE <input type="checkbox"/>
					\$		Lease Agreement with Non-SBE with SBE <input type="checkbox"/>
<b>TOTAL AMOUNT PAID</b>					\$		
PRIME CONTRACTOR		BUSINESS ADDRESS				BUSINESS PHONE NO.	

\* Upon request, all Lease Agreements shall be made available in accordance with the Special Provisions.

I CERTIFY THAT THE ABOVE INFORMATION IS COMPLETE AND CORRECT.

CONTRACTOR REPRESENTATIVE'S SIGNATURE	TITLE	DATE
---------------------------------------	-------	------



## MONTHLY SBE TRUCKING VERIFICATION INSTRUCTIONS

The top of Form contains boxes to put in the Contract Number, the Month of the reporting period and the Year of the reporting period.

The Form has a column to enter the name of the Truck Owner, the DBE/SBE Cert. No. (if DBE/SBE certified) and the Name and Address of the trucking company. The Form also requires the Truck No. and the California Highway Patrol CA No.

The Form is to be submitted prior to the 15<sup>th</sup> of each month and must show the dollar amount paid to the DBE/SBE trucking company(s) for trucking work performed by DBE/SBE certified trucks and for any fees or commissions of non-DBE/SBE trucks utilized each month on the project. The amount paid to each trucking company is to be entered in the column called "Commission or Amount Paid," in accordance with the Special Provisions **Section S11.05 (G)**.

Payment information is derived using the following:

1. 100% for the trucking services provided by the DBE/SBE using trucks it owns, operates and insures.
2. 100% for the trucking services provided by the trucks leased from other DBE/SBE firms.
3. The fee or commission paid to non-DBEs/SBEs for the lease of trucks. The Prime does not receive 100% credit for these services because they are not provided by a DBE/SBE company.

The total dollar figure of this column is to be placed in the box labeled "Total Amount Paid." The column "Date Paid" requires a date that each trucking company is paid for services rendered. The next column contains information that must be completed if a lease arrangement is applicable. Located at the bottom of the form is a space to put the name of the "Prime Contractor," their "Business Address" and their "Business Phone No."

At the bottom of the form there is a space for the Contractor or designee "Contractor Representative's Signature, Title and Date" certifying that the information provided on the form is complete and correct.

**SBE GOAL DECLARATION**

Bauman Landscape & Const. Inc.  
 Prime Contractor

03.01.001 and Ferry Landside Improvement Project  
 Contract Number and Name

- a)  **Check one or more that apply:**  
 \_\_\_\_\_ The Bidder/Proposer is a certified SBE in accordance with CITY OF SAUSALITO standards. A copy of our Certification (and, if required, Affidavit of Size) is enclosed.  
 \_\_\_\_\_ The Bidder/Proposer commits to subcontract at least \_\_\_\_\_% of its Total Bid Price with one or more certified SBEs for a Commercially Useful Function in the performance of the Contract.  
 \_\_\_\_\_ The Bidder/Proposer has NOT met the contract SBE goal and is not itself a certified SBE.

All Bidders must submit documentation of a verifiable Good Faith Effort with their Bid Proposal.

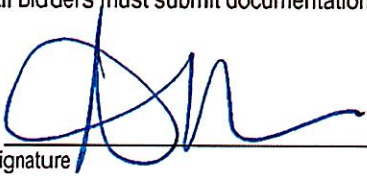
 \_\_\_\_\_  
 Signature

7/25/24  
 Date

**Documents to Be Included with Bid with SBE Goal**

	Invitation for Bid
SBE Goal Declaration	X
List of Subcontractors	X
Prime Contractor and Subcontractor/Subconsultant/Supplier Report	X
List of SBEs	X
Copies of SBE Certifications	X
Small Business Enterprise Affidavit of Size (as required; see list of acceptable certifications)	X
Good Faith Efforts Documentation	X

**SMALL BUSINESS ENTERPRISE AFFIDAVIT OF SIZE**

**Who should submit this form:**

If your business was certified by any of the following, please complete and submit this form with a copy of your Certification. This form may be used for Prime Contractors, Subcontractors, Subconsultants, and Suppliers. Your firm's average annual gross receipts must fall below the U.S. Small Business Administration (SBA) industry-specific size cap and in no case exceed \$30.72 million. (View SBA size table here: <https://www.sba.gov/content/table-small-business-size-standards> and click on size standards table link at bottom of web page.)

- SMBE/SWBE Certification by state other than California.
- SB/MICRO/SB-PW Certification by the California Department of General Services (DGS).
- SBA 8(a) Certification by the Small Business Administration.
- SBE/MBE/WBE Certification by other California county or local government-certifying agency or out-of-state government-certifying agency that conform with CITY OF SAUSALITO requirements.

See Special Provisions S11.02, SBE Eligibility, subsections A.1.a. and A.1.b., for further information on business size, and subsection B for list of all acceptable certifications.

I HEREBY DECLARE AND AFFIRM that I am the  
 \_\_\_\_\_  
 (Title) *Corporate Secretary*  
 and duly authorized representative of \_\_\_\_\_  
 (Name of Firm) *Bauman Landscape & Const. Inc.*  
 whose address is \_\_\_\_\_  
*100 Woodland Ave Suite 200, SF*  
 and whose phone is \_\_\_\_\_  
*415 447 4900*

I HEREBY DECLARE AND AFFIRM that the firm is a Small Business Enterprise (SBE) in accordance with CITY OF SAUSALITO (CITY OF SAUSALITO) standards as defined in its Diversity Program for Contracts. The firm is certified as of the date that the CITY OF SAUSALITO receives the bid/proposal for Contract No. 0301001-000, FERRY LANDSIDE IMPROVEMENT PROJECT.

**I will provide the certification to document this fact with this enclosure.**

I DO SOLEMNLY DECLARE AND AFFIRM UNDER THE PENALTIES OF PERJURY THAT THE CONTENTS OF THE FOREGOING STATEMENTS ARE TRUE AND CORRECT, AND THAT I AM AUTHORIZED, ON BEHALF OF THE ABOVE FIRM, TO MAKE THIS AFFIDAVIT.

*2/22* \_\_\_\_\_ *[Signature]* \_\_\_\_\_ *Corp. Secretary*  
 (Date) (Affiant) (Title)



# Certification Profile

## State of California Certification



**Certification ID: 1142566**

Legal Business Name

Bauman Landscape and Construction, Inc.

Doing Business As (DBA) Name1

Doing Business As (DBA) Name2

Office Phone Number

415/447-4800

Business Fax Number

Business Web Address

Service Areas

Marin , Napa , San Francisco , San Mateo , Sonoma

Address

2920 Lyon St

San Francisco

CA 94123

Email:

accounting@baumanland.com

Total Number of Employees

85

Business Types

Constuction

[View Keywords](#)

[View Classifications](#)

[View Supplier Diversity Information](#)

GOOD FAITH EFFORTS DOCUMENTATION

Instructions: Bidder must document Good Faith Efforts to meet the contract-specific SBE goal of 25.5%, even if the Bidder has met the goal. This form protects the Bidder's eligibility for award of the contract if the City of Sausalito determines that the Bidder failed to meet the goal for various reasons, e.g., a DBE/SBE firm was not certified at bid opening, or the Bidder made a mathematical error.

Contract # and Name: Contract No. 03.01.001 and Ferry Landside Improvement Project
Bidder's Name: Bauman Landscape & Const
Address: 2420 Lyon St., SF
Phone: 415 447 4000 Fax:
Owner or Contact Person: Ingrid Bauman Title: Comp. Secretary
E-mail: ange@baumanland.com

Bidder must provide a narrative description of steps taken to obtain SBE participation, including the following elements: (Please attach additional sheets as necessary.)

- A. A Company representative attended the pre-bid meeting. Yes \_\_\_ No [X]
B. Soliciting SBEs to participate through all reasonable and available means within sufficient time to allow the SBEs to respond to the solicitation.

List the names and dates of each publication in which a request for SBE participation for this project was placed by the bidder (attach copies of advertisements).

Table with 2 columns: Publications, Dates of Advertisements. Entries include 'Main Builders' with date '7/08/24' and 'Emails - DM' with 'attached'.

- C. Selecting portions of the work that are economically feasible for SBEs.

List items of work which the bidder made available to SBEs, including, where appropriate, any breaking down of the contract work items (including those items normally performed by the bidder with its own forces) into economically feasible units to facilitate SBE participation. It is the bidder's responsibility to demonstrate that sufficient work to facilitate SBE participation was made available to SBEs.

Table with 2 columns: Items of Work, Breakdown of Items. Entry includes 'Trucking'.

## Ahmed Alnajm

---

**From:** Ahmed Alnajm  
**Sent:** Wednesday, July 17, 2024 12:18 PM  
**To:** rries@ironsmith.biz  
**Cc:** jason@ironsmith.biz  
**Subject:** RE: Ferry Landside Improvement Project



Any update?  
Thanks,

**Ahmed Alnajm**  
Safety Manger and Estimator, Bauman Landscape &  
Construction



---

 [San Francisco, CA](#)  [www.baumanland.com](http://www.baumanland.com)

 [\(415\)447-4800](tel:(415)447-4800)  [415-447-4800](tel:415-447-4800)

 [ahmed@baumanland.com](mailto:ahmed@baumanland.com)

 100 Woodland Ave #200, San Rafael, CA 94901

---

**From:** Ahmed Alnajm  
**Sent:** Tuesday, July 16, 2024 12:07 PM  
**To:** 'rries@ironsmith.biz' <rries@ironsmith.biz>  
**Cc:** 'jason@ironsmith.biz' <jason@ironsmith.biz>  
**Subject:** Ferry Landside Improvement Project  
**Importance:** High

Hi Roxanne,

Please see the few items need to get a price for it, we need a 9 EA tree grates

Model: ADA-M6058, with two (2) holes for tree stakes, 100% recycled gray iron, 60" x 60," RAL 7026 Granite Grey; contractor to submit shop drawings. Manufacturer: Ironsmith, 41-701 Corporate Way #3 Palm Desert, CA 92260, (800-338-4766).

Project locations : 420 Litho Street, Sausalito, CA 94965 Project name : Ferry Landside Improvement Project

Due date : 7/19/2024 2:00pm

**NOTES:**

1. MFR: IRONSMITH
2. MODEL: ADA-M6058, W/ TWO (2) HOLES FOR TREE STAKES
3. MATERIAL: 100% RECYCLED GRAY IRON
4. SIZE: 60" x 60"
5. COLOR: RAL 7026 GRANITE GREY
6. CONTRACTOR TO SUBMIT SHOP DRAWINGS & INSTALL & ANCHOR PER MFR'S INSTRUCTIONS.

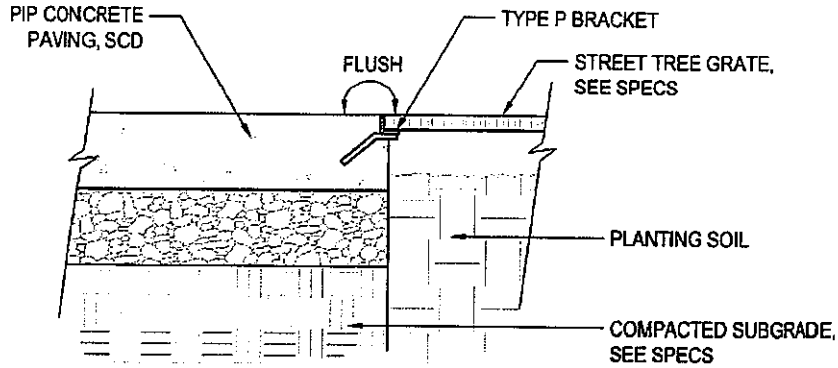

2

## TREE GRATE AT CONCRETE

SCALE: 1-1/2" = 1'-0"

Thanks,

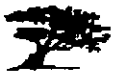

Ahmed Alnajm, MS | Estimating, Project Manager  
Bauman Landscape and Construction, Inc.  
2920 Lyon St., San Francisco, California 94123  
P:628.999.8394 Ext:108 C:279.204.3712



## Ahmed Alnajm

---

**From:** Ahmed Alnajm  
**Sent:** Wednesday, July 17, 2024 12:18 PM  
**To:** Cory Coulter  
**Subject:** RE: Ferry Landside Improvement Project

They mentioned on the specification must have leveling spacers.

**Ahmed Alnajm**  
Safety Manger and Estimator, Bauman Landscape &  
Construction



---

📍 San Francisco, CA 🌐 [www.baumanland.com](http://www.baumanland.com)

☎️ (415)447-4800 📠 415-447-4800

✉️ [ahmed@baumanland.com](mailto:ahmed@baumanland.com)

📍 100 Woodland Ave #200, San Rafael, CA 94901

---

**From:** Cory Coulter <cory@bearsaver.com>  
**Sent:** Wednesday, July 17, 2024 12:16 PM  
**To:** Ahmed Alnajm <ahmed@baumanland.com>  
**Subject:** RE: Ferry Landside Improvement Project

These mounting brackets.

Cory

**Cory Coulter**

**BEARSAVER / SECURR**  
P) 909-212-5379 – Cell) 909-210-0100 - f) 909-605-7780

PO Box 1438, Guasti, CA 91743  
1390 S. Milliken Ave. Ontario, CA 91761

**From:** Ahmed Alnajm <[ahmed@baumanland.com](mailto:ahmed@baumanland.com)>  
**Sent:** Wednesday, July 17, 2024 12:12 PM  
**To:** Cory Coulter <[cory@bearsaver.com](mailto:cory@bearsaver.com)>  
**Subject:** RE: Ferry Landside Improvement Project

Hi Cory,



Is your quote including required leveling spacers?  
Thanks,



Ahmed Alnajm, MS | Estimating, Project Manager  
Bauman Landscape and Construction, Inc.  
2920 Lyon St., San Francisco, California 94123  
P:628.999.8394 Ext:108 C:279.204.3712

**Ahmed Alnajm**  
Safety Manger and Estimator, Bauman Landscape &  
Construction



---

San Francisco, CA [www.baumanland.com](http://www.baumanland.com)

(415)447-4800 415-447-4800

[ahmed@baumanland.com](mailto:ahmed@baumanland.com)

100 Woodland Ave #200, San Rafael, CA 94901

---

**From:** Cory Coulter <[cory@bearsaver.com](mailto:cory@bearsaver.com)>  
**Sent:** Wednesday, July 17, 2024 7:36 AM  
**To:** Ahmed Alnajm <[ahmed@baumanland.com](mailto:ahmed@baumanland.com)>  
**Subject:** RE: Ferry Landside Improvement Project

Please see attached. Drawing shows base CG35, the opening shapes are stated inside the wording of the quote.  
Let me know how I may assist further.

Regards,

Cory

**Cory Coulter**

**BEARSAVER / SECURR**  
P) 909-212-5379 – Cell) 909-210-0100 - f) 909-605-7780

PO Box 1438, Guasti, CA 91743  
1390 S. Milliken Ave. Ontario, CA 91761

**From:** Steve at BearSaver <[steve@bearsaver.com](mailto:steve@bearsaver.com)>  
**Sent:** Tuesday, July 16, 2024 12:49 PM  
**To:** Cory Coulter <[cory@bearsaver.com](mailto:cory@bearsaver.com)>  
**Subject:** Fwd: Ferry Landside Improvement Project

Sausalito standards? Do you know this standard or was is something I worked on. I'm not at a computer until later.

Steve Thompson  
Director of Marketing and Sales  
Compumeric Engineering Inc  
dba BearSaver and Securr  
Office 909-212-5386  
Cell 714-225-4306

Begin forwarded message:

**From:** Ahmed Alnajm <[ahmed@baumanland.com](mailto:ahmed@baumanland.com)>  
**Date:** July 16, 2024 at 12:03:07 PM PDT  
**To:** Steve at BearSaver <[steve@bearsaver.com](mailto:steve@bearsaver.com)>  
**Subject:** Ferry Landside Improvement Project

Hi Steve ,

Please see the few items need to get a price for it, we need a 3 EA **TRASH RECEPTACLES**  
Model: CG35 (Waste, Recycling, Compost), Colors: Sky Blue (Recycling), Black (Waste), Fir  
Green (Compost). Contractor to confirm colors, openings, and graphics match existing  
Sausalito standards. Manufacturer – BEARSAVER/SECURR, PO Box 1438 Guasti, CA 91734, 909-  
212-5379.

Project locations : 420 Litho Street, Sausalito, CA 94965 Project name : Ferry  
Landside Improvement Project  
Due date : 7/19/2024 2:00pm



- NOTES
1. REFER TO SECTION 02-05-00
  2. MODEL CG35
  3. COLORS: RECYCLING - SKY BLUE  
WASTE - BLACK  
COMPOST - FIR GREEN
  4. ADDITIONAL SPECIFICATIONS FOR CORROSION RESISTANCE
  5. CONTRACTOR TO CONFIRM CITY STANDARDS REGARDING COLORS, OPENINGS AND GRAPHICS WITH THE CONTRACTOR TO INSTALL & TIGHEN PER MFR'S INSTRUCTIONS

7 WASTE RECEPTACLES  
SCALE: NTS

Thanks,



Ahmed Alnajm, MS | Estimating, Project Manager  
Bauman Landscape and Construction, Inc.  
2920 Lyon St., San Francisco, California 94123  
P:628.999.8394 Ext:108 C:279.204.3712

**Ahmed Alnajm**  
Safety Manger and Estimator, Bauman  
Landscape & Construction

---



 [San Francisco, CA](#)  [www.baumanland.com](http://www.baumanland.com)

 [\(415\)447-4800](tel:(415)447-4800)  [415-447-4800](tel:415-447-4800)

 [ahmed@baumanland.com](mailto:ahmed@baumanland.com)

 100 Woodland Ave #200, San Rafael, CA 94901

---

## Ahmed Alnajm

---

**From:** Ahmed Alnajm  
**Sent:** Tuesday, July 16, 2024 11:58 AM  
**To:** 'usa@vestre.com'  
**Cc:** Allegra Garretti  
**Subject:** Ferry Landside Improvement Project

**Importance:** High

Hi Allegra,

Please see the few items need to get a price for it, we need a 19 EA

Project locations : 420 Litho Street, Sausalito, CA 94965 Project name : Ferry Landside Improvement Project

Due date : 7/19/2024 2:00pm



Ahmed Alnajm, MS | Estimating, Project Manager  
Bauman Landscape and Construction, Inc.  
2920 Lyon St., San Francisco, California 94123  
P:628.999.8394 Ext:108 C:279.204.3712

## Ahmed Alnajm

---

**From:** Ahmed Alnajm  
**Sent:** Tuesday, July 16, 2024 11:56 AM  
**To:** Allegra Garretti  
**Cc:** chip@vestre.com  
**Subject:** Ferry Landside Improvement Project

**Importance:** High

Hi Allegra,

Please see the few items need to get a price for it, we need a 19 EA

Project locations : 420 Litho Street, Sausalito, CA 94965 Project name : Ferry Landside Improvement Project

Due date : 7/19/2024 2:00pm

**NOTES:**

1. MFR: VESTRE
2. MODEL: 696C VROOM BICYCLE RACK LARGE
3. MATERIAL & FINISH: POWDER-COATED ALUMINUM
4. COLOR: 7026 GRANITE GREY
5. MOUNTING: CASTING IN GROUND
6. CONTRACTOR TO INSTALL PER MFR'S INSTRUCTIONS.

VG

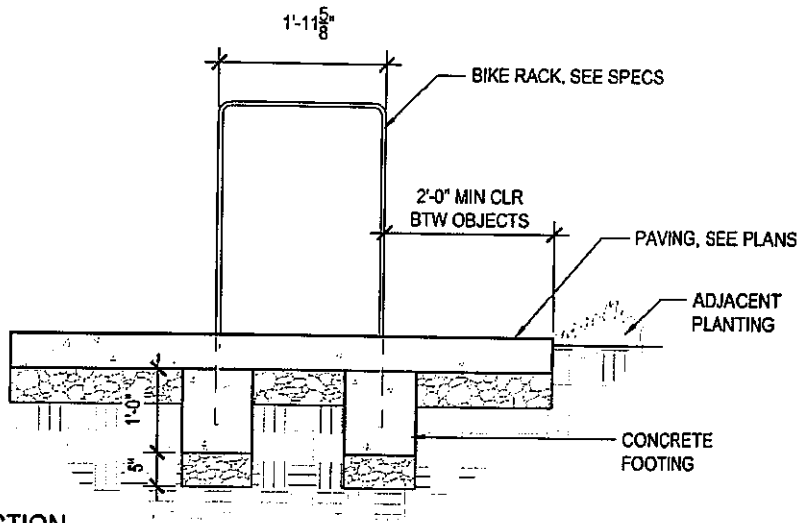

**SECTION**

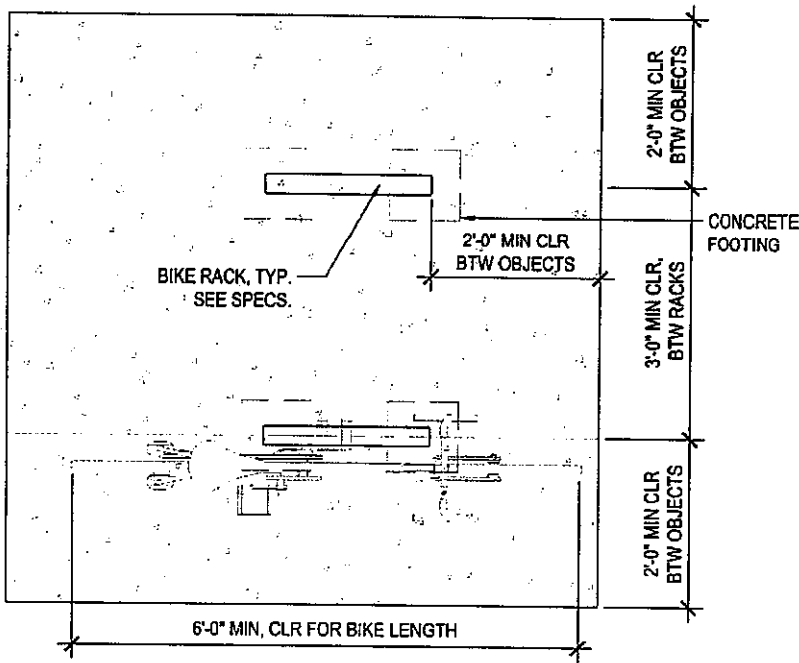

**PLAN**

3

**BIKE RACK**

SCALE:  $3/4" = 1'-0"$

Thanks,



Ahmed Alnajm, MS | Estimating, Project Manager  
Bauman Landscape and Construction, Inc.  
2920 Lyon St., San Francisco, California 94123  
P:628.999.8394 Ext:108 C:279.204.3712



## Ahmed Alnajm

---

**From:** Ahmed Alnajm  
**Sent:** Thursday, July 25, 2024 11:42 AM  
**To:** Ahmed Alnajm  
**Subject:** RE: Ferry Landside Improvement Project

**From:** Ahmed Alnajm  
**Sent:** Tuesday, July 16, 2024 11:52 AM  
**To:** Trisha Smith <TSmith@devilmountainnursery.com>  
**Subject:** Ferry Landside Improvement Project  
**Importance:** High

Hi Trisha,  
Please see the few items need to get a price for it,  
Project locations : 420 Litho Street, Sausalito, CA 94965 Project name : Ferry Landside Improvement Project  
Due date : 7/19/2024 2:00pm  
Thanks,



Ahmed Alnajm, MS | Estimating, Project Manager  
Bauman Landscape and Construction, Inc.  
2920 Lyon St., San Francisco, California 94123  
P:628.999.8394 Ext:108 C:279.204.3712

## Ahmed Alnajm

---

**From:** Ahmed Alnajm  
**Sent:** Thursday, July 25, 2024 11:44 AM  
**To:** Ahmed Alnajm  
**Subject:** FW: 2024 Ferry Landside Improvement Project  
**Attachments:** irri.xlsx  
  
**Importance:** High

**From:** Ahmed Alnajm  
**Sent:** Tuesday, July 16, 2024 10:07 AM  
**To:** Quote10 <Quote10@siteone.com>; Mark Pennington <MPennington@siteone.com>  
**Cc:** Paul Gordon <PG20259@siteone.com>; Andrew Tuckman <ATuckman@siteone.com>  
**Subject:** 2024 Ferry Landside Improvement Project  
**Importance:** High

Hi all,  
Please see the few items need to get a price for it,  
Project locations : 420 Litho Street, Sausalito, CA 94965 Project name : Ferry Landside Improvement Project  
Due date : 7/19/2024 2:00pm  
Thanks,

Ahmed Alnajm  
Safety Manger and Estimator, Bauman Landscape & Construction

---



📍 San Francisco, CA 🌐 [www.baumanland.com](http://www.baumanland.com)  
☎ (415)447-4800 📠 415-447-4800  
✉ [ahmed@baumanland.com](mailto:ahmed@baumanland.com)  
📍 100 Woodland Ave #200, San Rafael, CA 94901

---

## Ahmed Alnajm

---

**From:** Ahmed Alnajm  
**Sent:** Monday, July 22, 2024 10:51 AM  
**To:** chris@ct-electric.com  
**Subject:** RE: Document1.pdf

Hi Chris,  
Can you please send us a proposal,  
Please copy Mike,  
Thanks,



Ahmed Alnajm, MS | Estimating, Project Manager  
Bauman Landscape and Construction, Inc.  
2920 Lyon St., San Francisco, California 94123  
P:628.999.8394 Ext:108 C:279.204.3712

**From:** Ahmed Alnajm  
**Sent:** Wednesday, July 17, 2024 9:54 AM  
**To:** chris@ct-electric.com  
**Subject:** RE: Document1.pdf  
**Importance:** High

Chris,  
Follow this revised plan,  
Thanks,

**From:** Ahmed Alnajm  
**Sent:** Wednesday, July 17, 2024 9:29 AM  
**To:** [chris@ct-electric.com](mailto:chris@ct-electric.com)  
**Subject:** Document1.pdf  
**Importance:** High

Hi Chris,  
Can you please send me a proposal for the electrical,  
Get the price for the Bollard from Bega there is 16 EA with out light and on alternative 3 the will change the standard bollard to light bollards,,  
1-Model: 99 622 Non-Illuminated System Bollard Tube, 7 ½" diameter with B79817 Anchorage Kit, RAL 7026 Granite Grey; manufacturer: Bega, 1000 BEGA Way, Carpinteria, CA 93013, (805-684-0533). = 16 EA  
2- Model: 71 127 Non -Illuminated Cap, 7 ½" diameter, RAL 7026 Granite Grey; manufacturer: Bega, 1000 BEGA Way, Carpinteria, CA 93013, (805-684-0533). = 16 EA  
There is a Electrical manhole ,  
Project locations : 420 Litho Street, Sausalito, CA 94965 Project name : Ferry Landside Improvement Project  
Due date : 7/22/2024 2:00pm  
THANKS,

## Ahmed Alnajm

---

**From:** Ahmed Alnajm  
**Sent:** Monday, July 22, 2024 10:09 AM  
**To:** 'Guido Metzler'  
**Subject:** RE: Ferry Landside Improvement Project

Got it, thanks!

**From:** Guido Metzler <Guido@stripinggraphics.com>  
**Sent:** Monday, July 22, 2024 10:06 AM  
**To:** Ahmed Alnajm <ahmed@baumanland.com>  
**Subject:** RE: Ferry Landside Improvement Project

Here you go Ahmed

**From:** Ahmed Alnajm <ahmed@baumanland.com>  
**Sent:** Wednesday, July 17, 2024 1:07 PM  
**To:** Guido Metzler <Guido@stripinggraphics.com>  
**Subject:** Ferry Landside Improvement Project  
**Importance:** High

Hi Guido,

Can you please send me a proposal for the Ferry Landside Improvement Project,\  
The due date will be 7/22/2024 , 2:00 pm

[Ferry Landside Improvement Project - COPS24-02531 \(2\)](#)

Thanks,



Ahmed Alnajm, MS | Estimating, Project Manager  
Bauman Landscape and Construction, Inc.  
2920 Lyon St., San Francisco, California 94123  
P:628.999.8394 Ext:108 C:279.204.3712

Ahmed Alnajm

Safety Manger and Estimator, Bauman Landscape &  
Construction



---

San Francisco, CA [www.baumanland.com](http://www.baumanland.com)

(415)447-4800 415-447-4800

[ahmed@baumanland.com](mailto:ahmed@baumanland.com)

100 Woodland Ave #200, San Rafael, CA 94901

---

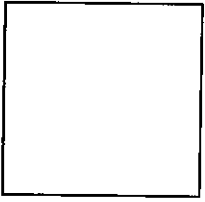

## Ahmed Alnajm

---

**From:** Ahmed Alnajm  
**Sent:** Monday, July 22, 2024 10:09 AM  
**To:** sales@invisiblestructures.com  
**Subject:** FERRY LANDSIDE IMPROVEMENT PROJECT  
**Attachments:** Document1.pdf  
  
**Importance:** High

Hi,  
Can you please provide a quote for "GravelPave 2," which includes recycled plastic meshing underneath covered with gravel  
Project : FERRY LANDSIDE IMPROVEMENT PROJECT  
Address : 420 Litho Street, Sausalito  
Thank,

**Ahmed Alnajm**  
Safety Manger and Estimator, Bauman Landscape &  
Construction



---

📍 San Francisco, CA 🌐 [www.baumanland.com](http://www.baumanland.com)  
☎ (415)447-4800 📠 415-447-4800  
✉ [ahmed@baumanland.com](mailto:ahmed@baumanland.com)

---





## Ahmed Alnajm

---

**From:** Ahmed Alnajm  
**Sent:** Friday, July 19, 2024 8:46 AM  
**To:** 'Nicole Meenan'; Roxanne Ries  
**Cc:** Alejandro Avalos; Jason Bet Sargon  
**Subject:** RE: FW: Ferry Laneside Improvement Project

Nicole & Roxanne,  
I received your quote guys,  
Thank you so much,



Ahmed Alnajm, MS | Estimating, Project Manager  
Bauman Landscape and Construction, Inc.  
2920 Lyon St., San Francisco, California 94123  
P:628.999.8394 Ext:108 C:279.204.3712

**From:** Nicole Meenan <mjb@mjbcorp.net>  
**Sent:** Thursday, July 18, 2024 10:00 PM  
**To:** Roxanne Ries <RRies@ironsmith.biz>  
**Cc:** Ahmed Alnajm <ahmed@baumanland.com>; Alejandro Avalos <aavalos@ironsmith.biz>; Jason Bet Sargon <jason@ironsmith.biz>  
**Subject:** Re: FW: Ferry Laneside Improvement Project

I sent everything to Ahmed Wednesday and Thursday shortly after I received the quotes for this project. I'll give him a call in the morning to make sure he received them. Maybe he's not opening my emails or they're going to his spam folder.

*Nicole Bonelli Meenan*

President

MJB Corporation

P: 530.272.8005 | [mjb@mjbcorp.net](mailto:mjb@mjbcorp.net) | <http://www.mjbcorp.net>

*Omega II Fence Systems • IRONSMITH • Old Town Fiberglass • Hauser Site*

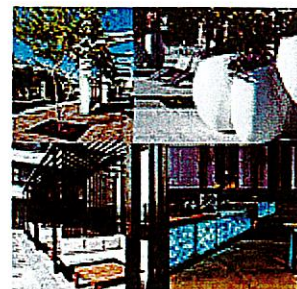
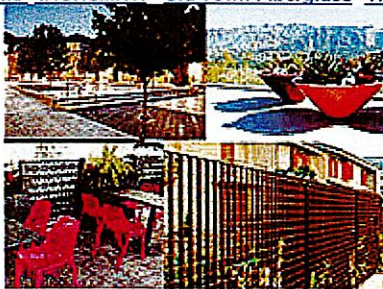

On Thu, Jul 18, 2024 at 5:54 PM Roxanne Ries <[RRies@ironsmith.biz](mailto:RRies@ironsmith.biz)> wrote:

Hi Alex,

Please provide a quote to Ahmed per his request below.

Thank you,

*Roxanne Ries*

*Customer Service Manager*

** IRONSMITH, INC.**

760-776-5077

[rries@ironsmith.biz](mailto:rries@ironsmith.biz)

E-Mail is covered by the Electronics Privacy Act, 18 U.S.C. Sections 2510-2521, and is legally privileged. This e-mail communication and any attachments may contain CONFIDENTIAL INFORMATION WHICH IS ALSO LEGALLY PRIVILEGED and which is intended only for the use of the intended recipient(s) identified above. If you are not the intended recipient of this communication, you are hereby notified that any use, dissemination, distribution, downloading or copying of this communication is strictly prohibited. If you have received this communication in error, please notify me immediately by e-mail, delete the communication and destroy all copies. Thank you for your cooperation.

---

**From:** Ahmed Alnajm [<mailto:ahmed@baumanland.com>]

**Sent:** Wednesday, July 17, 2024 12:18 PM

**To:** Roxanne Ries <[RRies@ironsmith.biz](mailto:RRies@ironsmith.biz)>

**Cc:** Jason Bet Sargon <[jason@ironsmith.biz](mailto:jason@ironsmith.biz)>

**Subject:** RE: Ferry Landside Improvement Project

Any update?

Thanks,



Ahmed Alnajm  
Safety Manger and Estimator, Bauman Landscape &  
Construction



📍 [San Francisco, CA](#) 🌐 [www.baumanland.com](http://www.baumanland.com)

☎️ [\(415\)447-4800](tel:(415)447-4800) 📠 [415-447-4800](tel:415-447-4800)

✉️ [ahmed@baumanland.com](mailto:ahmed@baumanland.com)

🏠 [100 Woodland Ave #200, San Rafael, CA 94901](#)

---

**From:** Ahmed Alnajm  
**Sent:** Tuesday, July 16, 2024 12:07 PM  
**To:** 'rries@ironsmith.biz' <rries@ironsmith.biz>  
**Cc:** 'jason@ironsmith.biz' <jason@ironsmith.biz>  
**Subject:** Ferry Landside Improvement Project  
**Importance:** High

Hi Roxanne,

Please see the few items need to get a price for it, we need a 9 EA tree grates

Model: ADA-M6058, with two (2) holes for tree stakes, 100% recycled gray iron, 60" x 60," RAL

7026 Granite Grey; contractor to submit shop drawings. Manufacturer: Ironsmith, 41-701

Corporate Way #3 Palm Desert, CA 92260, (800-338-4766).

Project locations : [420 Litho Street, Sausalito, CA 94965](#) Project name : Ferry Landside Improvement Project

Due date : 7/19/2024 2:00pm

**NOTES:**

1. MFR: IRONSMITH
2. MODEL: ADA-M6058, W/ TWO (2) HOLES FOR TREE STAKES
3. MATERIAL: 100% RECYCLED GRAY IRON
4. SIZE: 60" x 60"
5. COLOR: RAL 7026 GRANITE GREY
6. CONTRACTOR TO SUBMIT SHOP DRAWINGS & INSTALL & ANCHOR PER MFR'S INSTRUCTIONS.

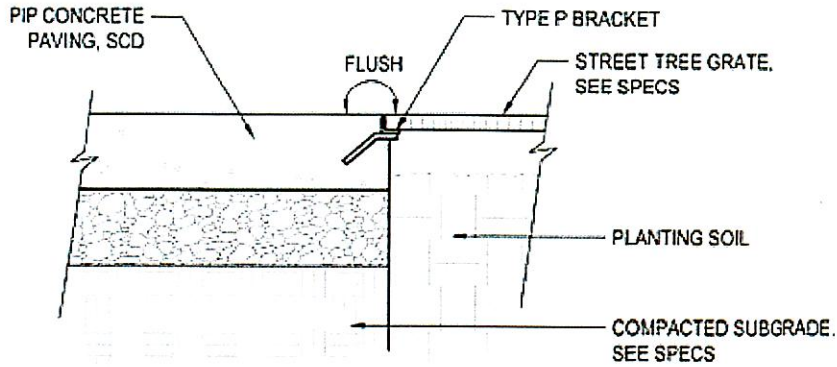

2

## TREE GRATE AT CONCRETE

SCALE: 1-1/2" = 1'-0"

Thanks,



Ahmed Alnajm, MS | Estimating, Project Manager

Bauman Landscape and Construction, Inc.

2920 Lyon St., San Francisco, California 94123

P:628.999.8394 Ext:108 C:279.204.3712



## Ahmed Alnajm

---

**From:** Ahmed Alnajm  
**Sent:** Wednesday, July 17, 2024 1:48 PM  
**To:** Brad Opitz  
**Subject:** RE: Ferry Landside Improvement Project

Awesome, thanks!

**From:** Brad Opitz <bopitz@pacesupply.com>  
**Sent:** Wednesday, July 17, 2024 1:39 PM  
**To:** Ahmed Alnajm <ahmed@baumanland.com>  
**Subject:** RE: Ferry Landside Improvement Project

Here you go.

**From:** Ahmed Alnajm <ahmed@baumanland.com>  
**Sent:** Wednesday, July 17, 2024 1:16 PM  
**To:** Brad Opitz <bopitz@pacesupply.com>  
**Subject:** Ferry Landside Improvement Project  
**Importance:** High

**CAUTION:** This email originated from outside PACE. Don't click links or open attachments unless you recognize the sender and know the content is safe.

Hi Brad,  
Can you please send me quote for the drinking fountain,  
Thanks,

▫

**From:** Sharon Norwood <snorwood@mlsalesinc.com>  
**Sent:** Wednesday, July 17, 2024 1:12 PM  
**To:** Ahmed Alnajm <ahmed@baumanland.com>  
**Subject:** FW: Ferry Landside Improvement Project  
**Importance:** High

Hi Ahmed,

I'm sorry we can't quote you direct. You will have to get your pricing through your local plumbing wholesaler. Anyone of the following will be able to help you  
Pace – San Francisco - 415-644-4900  
Keller Supply – San Francisco 415-675-8819  
Ferguson – San Leandro 510-394-6011  
Cal Steam – Emeryville 510-594-0400  
WHCI – Union City 510-471-5757

Thank you,  
Sharon



Sharon Norwood  
Mainline Sales, Inc.  
Phone: (510) 216-3495  
Email: [snorwood@mlsalesinc.com](mailto:snorwood@mlsalesinc.com)

**From:** Ahmed Alnajm <[ahmed@baumanland.com](mailto:ahmed@baumanland.com)>  
**Sent:** Tuesday, July 16, 2024 12:31 PM  
**To:** Customer Service Mainline <[CustomerService@mlsalesinc.com](mailto:CustomerService@mlsalesinc.com)>  
**Subject:** Ferry Landside Improvement Project  
**Importance:** High

Hi,

Please see the few items need to get a price for it, we need a 1 EA **DRINKING FOUNTAIN**  
Model : LK4420BF1U, Elkay Outdoor ez H2o Upper Bottle Filling Station Bi-Level Pedestal Non-Filtered Non-Refrigerated Drinking Fountain; color: Evergreen (EVG). Manufacturer: ELKAY 1-800-476-4106.

Project locations : 420 Litho Street, Sausalito, CA 94965 Project name : Ferry Landside Improvement Project

**NOTES:**

1. **MFR:** ELKAY
2. **MODEL:** LK4420BF1U - OUTDOOR ezH2O UPPER BOTTLE FILLING STATION BI-LEVEL PEDESTAL NON-FILTERED NON-REFRIGERATED
3. **COLOR:** GREY
4. **CONTRACTOR TO INSTALL & ANCHOR PER MFR'S INSTRUCTIONS.**

**OPERATING**  
Supply water

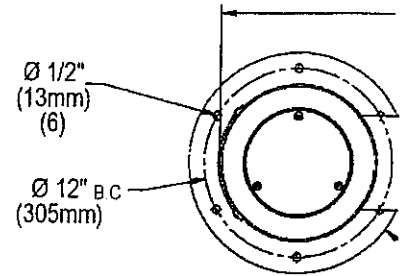

**FRONT & SIDE VIEW**

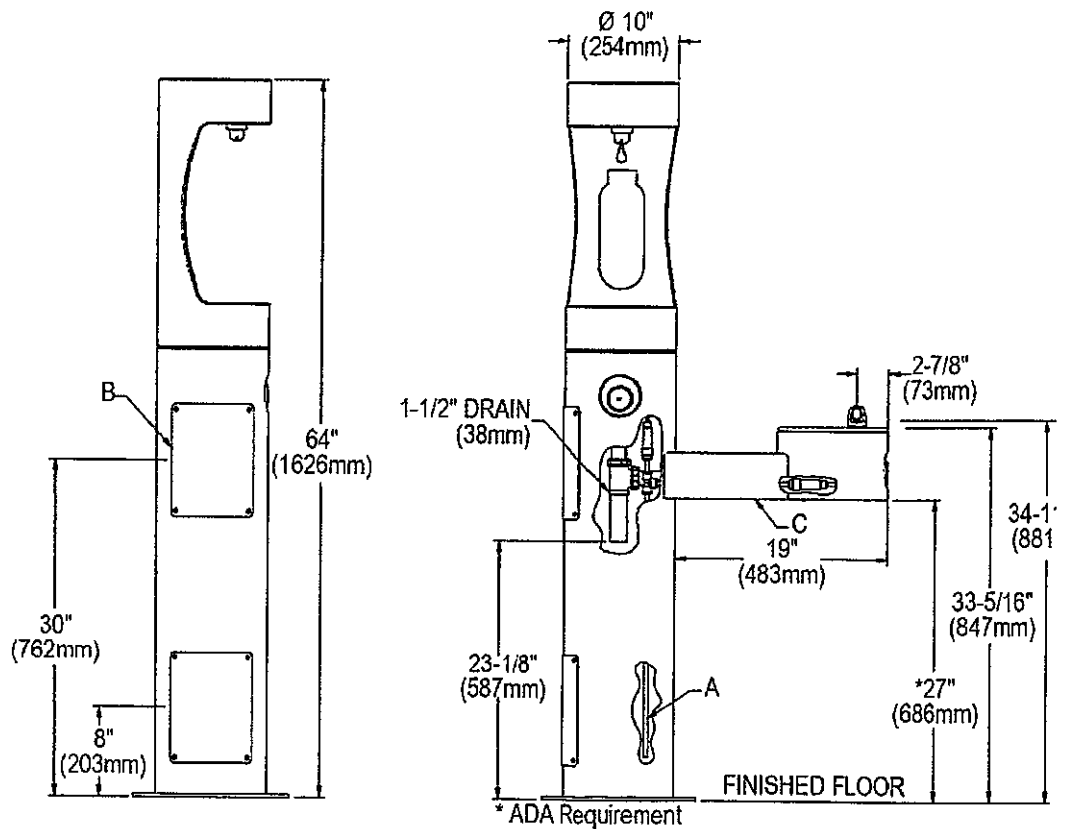

A = 3/8" O.D. Unplated copper tube connect. Shut off valve by others.  
 B = Access panel(8" x 10").  
 C = Removable bottom cover.  
 Note : New Installations Must Use Ground Fault Circuit Interrupter (GFCI).

**1 DRINKING FOUNTAIN**  
SCALE: NTS

Due date : 7/19/2024 2:00pm

**Ahmed Alnajm**  
Safety Manger and Estimator, Bauman Landscape &  
Construction

---



 [San Francisco, CA](#)  [www.baumanland.com](http://www.baumanland.com)

 [\(415\)447-4800](tel:(415)447-4800)  [415-447-4800](tel:415-447-4800)

 [ahmed@baumanland.com](mailto:ahmed@baumanland.com)

 100 Woodland Ave #200, San Rafael, CA 94901

---

□



## Ahmed Alnajm

---

**From:** Ahmed Alnajm  
**Sent:** Wednesday, July 17, 2024 1:19 PM  
**To:** Nakista Rodrigues  
**Cc:** Dave Morris  
**Subject:** RE: Ferry Landside Improvement Project

Great, thanks for the update.



Ahmed Alnajm, MS | Estimating, Project Manager  
Bauman Landscape and Construction, Inc.  
2920 Lyon St., San Francisco, California 94123  
P:628.999.8394 Ext:108 C:279.204.3712

**From:** Nakista Rodrigues <nakistaq@chrispco.com>  
**Sent:** Wednesday, July 17, 2024 1:17 PM  
**To:** Ahmed Alnajm <ahmed@baumanland.com>  
**Cc:** Dave Morris <dmorris@chrispco.com>  
**Subject:** RE: Ferry Landside Improvement Project

Hi Ahmed,

We are bidding on this project. I will get you added to our bidders list to receive our quote once ready.

Regards,

**Nakista Quiales**

Estimating Coordinator

**Chrisp Company** | 43650 Osgood Rd, Fremont, CA 94539

**O:** 510.656.2840 | **D:** 510.933.3935 | **F:** 510.656.2397 | ✉ [nakistaQ@chrispco.com](mailto:nakistaQ@chrispco.com)



**From:** Ahmed Alnajm <ahmed@baumanland.com>  
**Sent:** Wednesday, July 17, 2024 1:05 PM  
**To:** Chrisp Company Estimating <b2wemailer@chrispco.com>  
**Cc:** Nakista Rodrigues <nakistaq@chrispco.com>; Dave Morris <dmorris@chrispco.com>  
**Subject:** Ferry Landside Improvement Project  
**Importance:** High

**CAUTION:** This email originated from outside of the organization. Do not click links or open attachments unless you recognize the sender and know the content is safe.

Hi,



Can you please send me a proposal for the Ferry Landside Improvement Project,\nThe due date will be 7/22/2024 , 2:00 pm

[Ferry Landside Improvement Project - COPS24-02531 \(2\)](#)

Thanks,



Ahmed Alnajm, MS | Estimating, Project Manager  
Bauman Landscape and Construction, Inc.  
2920 Lyon St., San Francisco, California 94123  
P:628.999.8394 Ext:108 C:279.204.3712

**Ahmed Alnajm**  
Safety Manger and Estimator, Bauman Landscape &  
Construction



---

[San Francisco, CA](#) [www.baumanland.com](http://www.baumanland.com)

[\(415\)447-4800](tel:(415)447-4800) [415-447-4800](tel:415-447-4800)

[ahmed@baumanland.com](mailto:ahmed@baumanland.com)

100 Woodland Ave #200, San Rafael, CA 94901

---

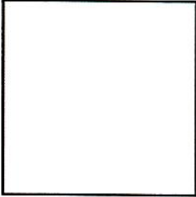

## Ahmed Alnajm

---

**From:** Ahmed Alnajm  
**Sent:** Wednesday, July 17, 2024 1:16 PM  
**To:** Brad Opitz  
**Subject:** Ferry Landside Improvement Project  
**Importance:** High

Hi Brad,  
Can you please send me quote for the drinking fountain,  
Thanks,

**From:** Sharon Norwood <[snorwood@mlsalesinc.com](mailto:snorwood@mlsalesinc.com)>  
**Sent:** Wednesday, July 17, 2024 1:12 PM  
**To:** Ahmed Alnajm <[ahmed@baumanland.com](mailto:ahmed@baumanland.com)>  
**Subject:** FW: Ferry Landside Improvement Project  
**Importance:** High

Hi Ahmed,

I'm sorry we can't quote you direct. You will have to get your pricing through your local plumbing wholesaler. Anyone of the following will be able to help you  
Pace – San Francisco - 415-644-4900  
Keller Supply – San Francisco 415-675-8819  
Ferguson – San Leandro 510-394-6011  
Cal Steam – Emeryville 510-594-0400  
WHCI – Union City 510-471-5757

Thank you,  
Sharon



Sharon Norwood  
Mainline Sales, Inc.  
Phone: (510) 216-3495  
Email: [snorwood@mlsalesinc.com](mailto:snorwood@mlsalesinc.com)

**From:** Ahmed Alnajm <[ahmed@baumanland.com](mailto:ahmed@baumanland.com)>  
**Sent:** Tuesday, July 16, 2024 12:31 PM  
**To:** Customer Service Mainline <[CustomerService@mlsalesinc.com](mailto:CustomerService@mlsalesinc.com)>  
**Subject:** Ferry Landside Improvement Project  
**Importance:** High

Hi,  
Please see the few items need to get a price for it, we need a 1 EA **DRINKING FOUNTAIN**  
Model : LK4420BF1U, Elkay Outdoor ez H2o Upper Bottle Filling Station Bi-Level Pedestal Non-

Filtered Non-Refrigerated Drinking Fountain; color: Evergreen (EVG). Manufacturer: ELKAY 1-800-476-4106.

Project locations : 420 Litho Street, Sausalito, CA 94965 Project name : Ferry Landside Improvement Project

**NOTES:**

1. **MFR:** ELKAY
2. **MODEL:** LK4420BF1U - OUTDOOR 6ZH20 UPPER BOTTLE FILLING STATION BI-LEVEL PEDESTAL NON-FILTERED NON-REFRIGERATED
3. **COLOR:** GREY
4. **CONTRACTOR TO INSTALL & ANCHOR PER MFR'S INSTRUCTIONS.**

**OPERATING**  
Supply water

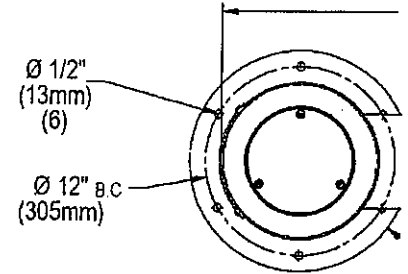

**FRONT & SIDE VIEW**

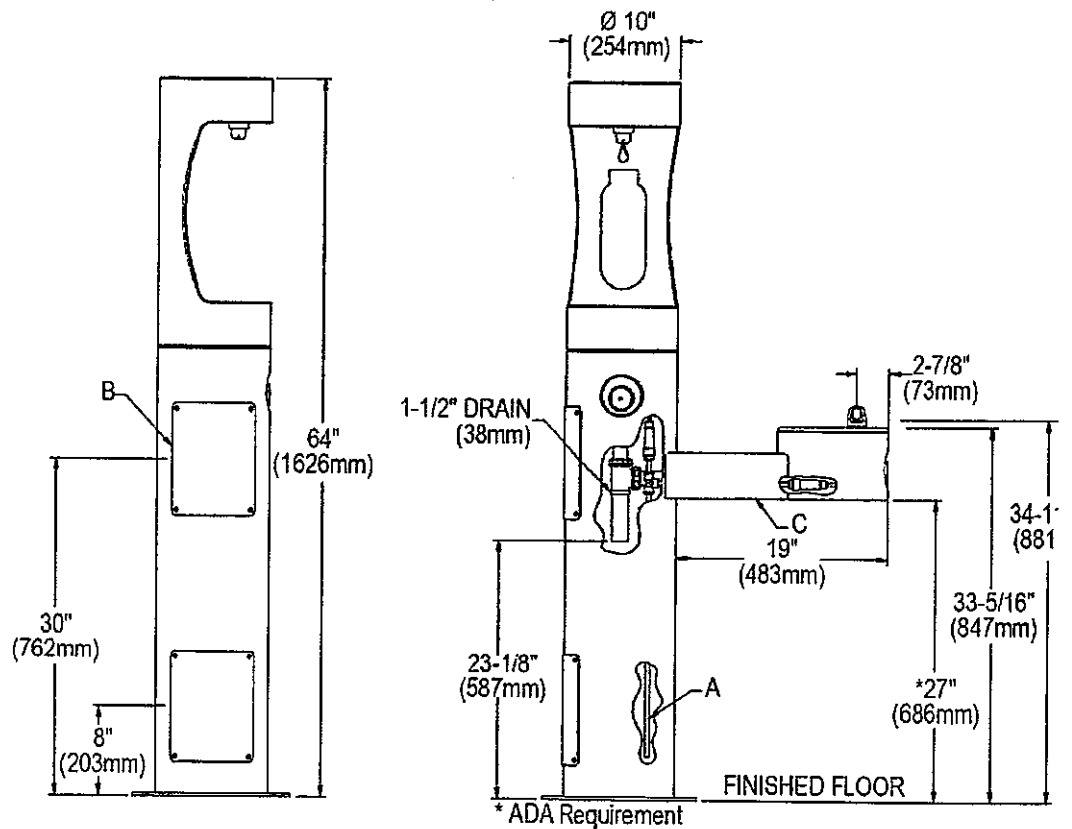

A = 3/8" O.D. Unplated copper tube connect. Shut off valve by others.  
 B = Access panel(8" x 10").  
 C = Removable bottom cover.  
 Note : New Installations Must Use Ground Fault Circuit Interrupter (GFCI).

**1 DRINKING FOUNTAIN**  
SCALE: NTS



Due date : 7/19/2024 2:00pm

**Ahmed Alnajm**  
Safety Manger and Estimator, Bauman Landscape &  
Construction

---



 [San Francisco, CA](#)  [www.baumanland.com](http://www.baumanland.com)

 [\(415\)447-4800](tel:(415)447-4800)  [415-447-4800](tel:415-447-4800)

 [ahmed@baumanland.com](mailto:ahmed@baumanland.com)

 100 Woodland Ave #200, San Rafael, CA 94901

---

□

## Ahmed Alnajm

---

**From:** Ahmed Alnajm  
**Sent:** Monday, July 22, 2024 11:29 AM  
**To:** Denise Baker  
**Cc:** Mike Bauman; Angela Bauman  
**Subject:** RE: Ferry Landside Improvement Project

Hi Denise,  
The plans and spec mentioned there is a Reset NGS benchmark & Reset Survey Monument,

26.	RESET NGS BENCHMARK	EA	1		
27.	RESET SURVEY MONUMENT	EA	1		

Please see sec. 02 21 14  
Thanks,

**Ahmed Alnajm**  
Safety Manger and Estimator, Bauman Landscape &  
Construction



---

📍 San Francisco, CA 🌐 [www.baumanland.com](http://www.baumanland.com)  
☎ (415)447-4800 📠 415-447-4800  
✉ [ahmed@baumanland.com](mailto:ahmed@baumanland.com)

---

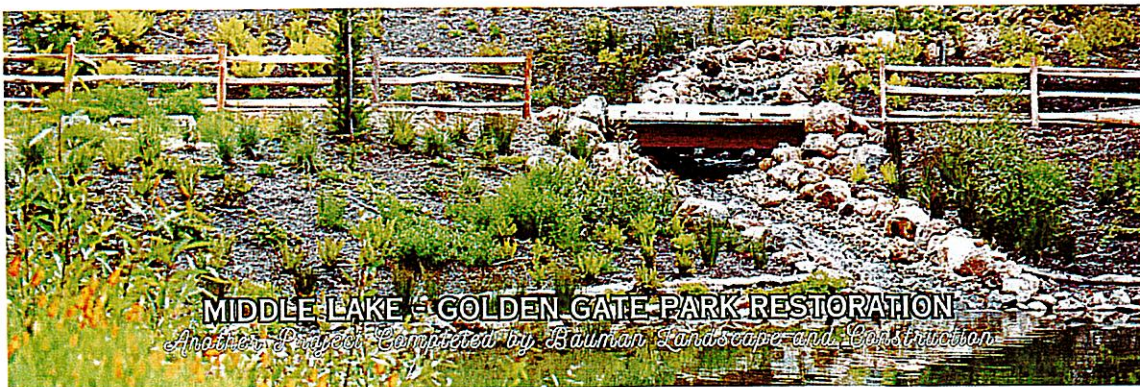

**From:** Denise Baker <[dbaker@constructionsurveyinc.com](mailto:dbaker@constructionsurveyinc.com)>  
**Sent:** Monday, July 22, 2024 11:21 AM  
**To:** Ahmed Alnajm <[ahmed@baumanland.com](mailto:ahmed@baumanland.com)>  
**Subject:** RE: Ferry Landside Improvement Project



Hi Ahmed,

The plans & specs indicate that the City will be referencing monuments/benchmarks, and you'll coordinate with them if any need to be replaced.

Call me on my mobile if you have any questions.

Thanks,

*Denise Baker, L.S.*  
**Construction Survey, Inc.**  
**800 Bancroft Way, #201**  
**Berkeley, CA 94710**

510-526-0993 office | 925-330-1266 cell



**From:** Ahmed Alnajm <[ahmed@baumanland.com](mailto:ahmed@baumanland.com)>  
**Sent:** Monday, July 22, 2024 11:18 AM  
**To:** Denise Baker <[dbaker@constructionsurveyinc.com](mailto:dbaker@constructionsurveyinc.com)>  
**Subject:** FW: Ferry Landside Improvement Project  
**Importance:** High

Good morning,  
Can you please send us a proposal,  
Thanks,

**Ahmed Alnajm**  
Safety Manger and Estimator, Bauman Landscape &  
Construction



 [San Francisco, CA](#)  [www.baumanland.com](http://www.baumanland.com)

 [\(415\)447-4800](tel:(415)447-4800)  [415-447-4800](tel:415-447-4800)

 [ahmed@baumanland.com](mailto:ahmed@baumanland.com)

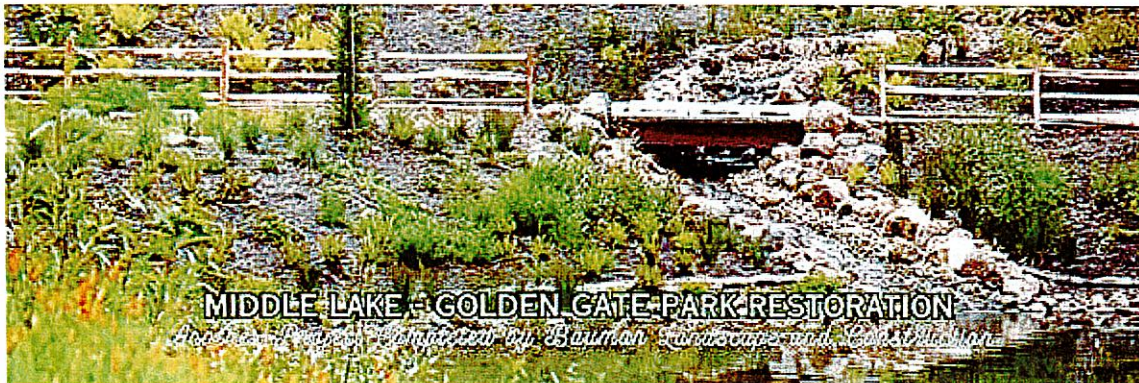

**From:** Ahmed Alnajm  
**Sent:** Monday, July 22, 2024 10:52 AM  
**To:** dtahan constructionsurveyinc.com <[dtahan@constructionsurveyinc.com](mailto:dtahan@constructionsurveyinc.com)>  
**Cc:** [dls10379@gmail.com](mailto:dls10379@gmail.com); [dbaker@constructionsurveyinc.com](mailto:dbaker@constructionsurveyinc.com)  
**Subject:** RE: Ferry Landside Improvement Project  
**Importance:** High

Hi,  
Can you please send me the proposal,  
The due date will be today,  
Thanks,

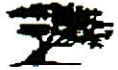

Ahmed Alnajm, MS | Estimating, Project Manager  
Bauman Landscape and Construction, Inc.  
2920 Lyon St., San Francisco, California 94123  
P:628.999.8394 Ext:108 C:279.204.3712

**From:** Ahmed Alnajm  
**Sent:** Wednesday, July 17, 2024 1:15 PM  
**To:** dtahan constructionsurveyinc.com <[dtahan@constructionsurveyinc.com](mailto:dtahan@constructionsurveyinc.com)>  
**Cc:** [dls10379@gmail.com](mailto:dls10379@gmail.com); [dbaker@constructionsurveyinc.com](mailto:dbaker@constructionsurveyinc.com)  
**Subject:** Ferry Landside Improvement Project  
**Importance:** High

Hi,  
Can you please send me a proposal for the Ferry Landside Improvement Project,\  
There is a Bench Mark Reset and reset survey monument there is a bid items for that please see addendum 2 ( 27 &28 )  
The due date will be 7/22/2024 , 2:00 pm  
 [Ferry Landside Improvement Project - COPS24-02531 \(2\)](#)

Thanks,



Ahmed Alnajm, MS | Estimating, Project Manager  
Bauman Landscape and Construction, Inc.  
2920 Lyon St., San Francisco, California 94123  
P:628.999.8394 Ext:108 C:279.204.3712





## Ahmed Alnajm

---

**From:** Ahmed Alnajm  
**Sent:** Monday, July 22, 2024 11:18 AM  
**To:** dbaker@constructionsurveyinc.com  
**Subject:** FW: Ferry Landside Improvement Project

**Importance:** High

Good morning,  
Can you please send us a proposal,  
Thanks,

**Ahmed Alnajm**  
Safety Manger and Estimator, Bauman Landscape &  
Construction



---

📍 San Francisco, CA 🌐 [www.baumanland.com](http://www.baumanland.com)

☎ (415)447-4800 📠 415-447-4800

✉ [ahmed@baumanland.com](mailto:ahmed@baumanland.com)

---



**From:** Ahmed Alnajm  
**Sent:** Monday, July 22, 2024 10:52 AM  
**To:** dtehan@constructionsurveyinc.com <dtehan@constructionsurveyinc.com>  
**Cc:** dls10379@gmail.com; dbaker@constructionsurveyinc.com  
**Subject:** RE: Ferry Landside Improvement Project  
**Importance:** High

Hi,  
Can you please send me the proposal,

The due date will be today,  
Thanks,



Ahmed Alnajm, MS | Estimating, Project Manager  
Bauman Landscape and Construction, Inc.  
2920 Lyon St., San Francisco, California 94123  
P:628.999.8394 Ext:108 C:279.204.3712

**From:** Ahmed Alnajm  
**Sent:** Wednesday, July 17, 2024 1:15 PM  
**To:** [dtehan@constructionsurveyinc.com](mailto:dtehan@constructionsurveyinc.com) <[dtehan@constructionsurveyinc.com](mailto:dtehan@constructionsurveyinc.com)>  
**Cc:** [dls10379@gmail.com](mailto:dls10379@gmail.com); [dbaker@constructionsurveyinc.com](mailto:dbaker@constructionsurveyinc.com)  
**Subject:** Ferry Landside Improvement Project  
**Importance:** High

Hi,  
Can you please send me a proposal for the Ferry Landside Improvement Project,\  
There is a Bench Mark Reset and reset survey monument there is a bid items for that please see addendum 2 ( 27  
&28 )  
The due date will be 7/22/2024 , 2:00 pm  
 [Ferry Landside Improvement Project - COPS24-02531 \(2\)](#)

Thanks,



Ahmed Alnajm, MS | Estimating, Project Manager  
Bauman Landscape and Construction, Inc.  
2920 Lyon St., San Francisco, California 94123  
P:628.999.8394 Ext:108 C:279.204.3712

## Ahmed Alnajm

---

**From:** Ahmed Alnajm  
**Sent:** Monday, July 22, 2024 10:59 AM  
**To:** OI-NorCalEstimating  
**Cc:** Villalobos, Israel  
**Subject:** RE: 2024 Ferry Landside Improvement Project

**Importance:** High

I already sent it last week,  
Its only one items!  
Thanks

**Ahmed Alnajm**  
Safety Manger and Estimator, Bauman Landscape &  
Construction



---

📍 San Francisco, CA 🌐 [www.baumanland.com](http://www.baumanland.com)  
☎ (415)447-4800 📠 415-447-4800  
✉ [ahmed@baumanland.com](mailto:ahmed@baumanland.com)

---

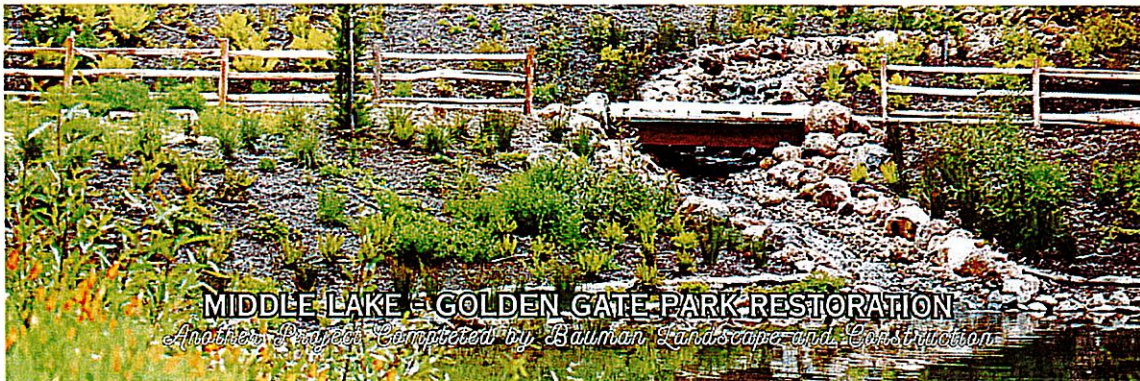

**From:** Villalobos, Israel <Israel.Villalobos@oldcastle.com> **On Behalf Of** OI-NorCalEstimating  
**Sent:** Monday, July 22, 2024 10:57 AM  
**To:** Ahmed Alnajm <ahmed@baumanland.com>  
**Subject:** FW: 2024 Ferry Landside Improvement Project  
**Importance:** High

Hello Ahmed,



My apologies, but we will not be able to provide a quote for this item. I am short estimators today and will not have to put a quote by today.

Sincerely,

Israel Villalobos

---

**From:** Ahmed Alnajm <[ahmed@baumanland.com](mailto:ahmed@baumanland.com)>  
**Sent:** Wednesday, July 17, 2024 12:10 PM  
**To:** Hoskins, Natasha <[Natasha.Hoskins@oldcastle.com](mailto:Natasha.Hoskins@oldcastle.com)>  
**Subject:** [EXT] RE: 2024 Ferry Landside Improvement Project

Okay I will,  
Thanks,



Ahmed Alnajm, MS | Estimating, Project Manager  
Bauman Landscape and Construction, Inc.  
2920 Lyon St., San Francisco, California 94123  
P:628.999.8394 Ext:108 C:279.204.3712

**Ahmed Alnajm**  
**Safety Manger and Estimator, Bauman Landscape & Construction**



---

[San Francisco, CA](#) [www.baumanland.com](http://www.baumanland.com)

[\(415\)447-4800](tel:(415)447-4800) [415-447-4800](tel:415-447-4800)

[ahmed@baumanland.com](mailto:ahmed@baumanland.com)

100 Woodland Ave #200, San Rafael, CA 94901

---

▫  
**From:** Hoskins, Natasha <[Natasha.Hoskins@oldcastle.com](mailto:Natasha.Hoskins@oldcastle.com)>  
**Sent:** Wednesday, July 17, 2024 12:09 PM  
**To:** Ahmed Alnajm <[ahmed@baumanland.com](mailto:ahmed@baumanland.com)>  
**Subject:** Re: 2024 Ferry Landside Improvement Project

Ahmed, Please send your quote request to [oi-NorCalEstimating@Oldcastle.com](mailto:oi-NorCalEstimating@Oldcastle.com)



Natasha Hoskins

Estimator / Stormwater Project Lead -  
Northern California

C 707.249.2765

E [natasha.hoskins@oldcastle.com](mailto:natasha.hoskins@oldcastle.com)

**Estimating Email**  
[Oi-NorCalEstimating@oldcastle.com](mailto:Oi-NorCalEstimating@oldcastle.com)

[oldcastleinfrastructure.com](http://oldcastleinfrastructure.com)

We require a project information sheet for all orders over \$25K to be submitted electronically via GoFormz or your order will be placed on hold. Our electronic project info sheet is available at this link, [Project Information Sheet](#).

To open an account with Oldcastle Infrastructure, please use the link below.

<https://na4-onlineapp.dnbi.com/createApp/Oldcastle+Inc?token=wT7rNtJxK51PM9pHn12oQA%3D%3D>

Please submit ALL Lien releases to: [lienwaivers@oldcastle.com](mailto:lienwaivers@oldcastle.com)

***WILL CALL HOURS 7:00am to 1:00pm "NO DUMP TRUCKS PERMITTED FOR WILL CALL PICK UP. All persons entering the facility must have PPE - personal protective equipment. Enter facility with extreme caution and obey all posted signs. Customer must provide own wood/dunnage for material to set on and straps to secure material on flatbed truck/trailer."***

---

**From:** Ahmed Alnajm <[ahmed@baumanland.com](mailto:ahmed@baumanland.com)>  
**Sent:** Wednesday, July 17, 2024 9:43 AM  
**To:** Hoskins, Natasha <[Natasha.Hoskins@oldcastle.com](mailto:Natasha.Hoskins@oldcastle.com)>  
**Subject:** [EXT] FW: 2024 Ferry Landside Improvement Project

**CAUTION: this email originated from outside of the organization. Do not click links or open attachments unless you are expecting this email and know the contents are safe.**

---

Hi Natasha,  
Can you get a price for this manhole,  
Project locations : 420 Litho Street, Sausalito, CA 94965 Project name : Market Octavia Living Alleyways Phase 1A  
Due date : 7/19/2024 2:00pm

Thanks,

The screenshot shows the Oldcastle Infrastructure website. The header includes the company logo, navigation links for Project Location, Locations, Specified Products, and a phone number (866) 962-3227. A secondary navigation bar lists Markets, Brands, Solutions, Insights Center, Support, Resources, About Us, and Design Tools. The main content area features a large title "4'x6' Communication Vault w/Manhole" over a dark, textured background. Below the title is a 3D rendering of a rusted metal vault with a manhole on top. To the right of the rendering is a sidebar with navigation links: Overview, Features & Benefits, and Specs & Guides. Below the sidebar is a blue box with the text "Whether you're lo". At the bottom of the rendering area are two small thumbnail images of the vault.

Thanks,

Ahmed Alnajm  
Safety Manger and Estimator, Bauman Landscape &  
Construction



San Francisco, CA [www.baumanland.com](http://www.baumanland.com)

(415)447-4800 415-447-4800

[ahmed@baumanland.com](mailto:ahmed@baumanland.com)

100 Woodland Ave #200, San Rafael, CA 94901

□



## Ahmed Alnajm

---

**From:** Ahmed Alnajm  
**Sent:** Wednesday, July 17, 2024 1:06 PM  
**To:** Renee Norman  
**Subject:** RE: Ferry Landside Improvement Project

Sounds good, thank you.

**From:** Renee Norman <[rnorman@goldenstatelumber.com](mailto:rnorman@goldenstatelumber.com)>  
**Sent:** Wednesday, July 17, 2024 1:02 PM  
**To:** Ahmed Alnajm <[ahmed@baumanland.com](mailto:ahmed@baumanland.com)>  
**Subject:** RE: Ferry Landside Improvement Project

Waiting on cost of 8x8 from vendor.

Will send as soon as I have.

**Renee Norman** - Sales

GOLDEN STATE

Direct 415-444-9183 | Cell 415-640-2067 | Fax 415-454-6318

[rnorman@goldenstatelumber.com](mailto:rnorman@goldenstatelumber.com)

1100 Andersen Drive San Rafael, CA 94901 |

[www.goldenstatelumber.com](http://www.goldenstatelumber.com)

Golden State has been voted a Great Place to Work by our employees

**From:** Ahmed Alnajm <[ahmed@baumanland.com](mailto:ahmed@baumanland.com)>  
**Sent:** Wednesday, July 17, 2024 12:57 PM  
**To:** Renee Norman <[rnorman@goldenstatelumber.com](mailto:rnorman@goldenstatelumber.com)>  
**Subject:** RE: Ferry Landside Improvement Project

EXTERNAL EMAIL - This email was sent by a person from outside your organization. Exercise caution when clicking links, opening attachments or taking further action, before validating its authenticity.

Any update?

Thanks,

Ahmed Alnajm

Safety Manger and Estimator, Bauman Landscape &  
Construction



---

San Francisco, CA [www.baumanland.com](http://www.baumanland.com)

(415)447-4800 415-447-4800

---

---

✉ [ahmed@baumanland.com](mailto:ahmed@baumanland.com)

📍 100 Woodland Ave #200, San Rafael, CA 94901

---

**From:** Ahmed Alnajm  
**Sent:** Tuesday, July 16, 2024 4:47 PM  
**To:** Renee Norman <[rnorman@goldenstatelumber.com](mailto:rnorman@goldenstatelumber.com)>  
**Subject:** Ferry Landside Improvement Project  
**Importance:** High

Hi Renee,

Please see the item need to get a price for it, we need a 28 EA **wooden post pre treated W/Chamfer 1" 8"x8"x 5'**

Project locations : 420 Litho Street, Sausalito, CA 94965 Project name : Ferry Landside Improvement Project

Due date : 7/19/2024 2:00pm

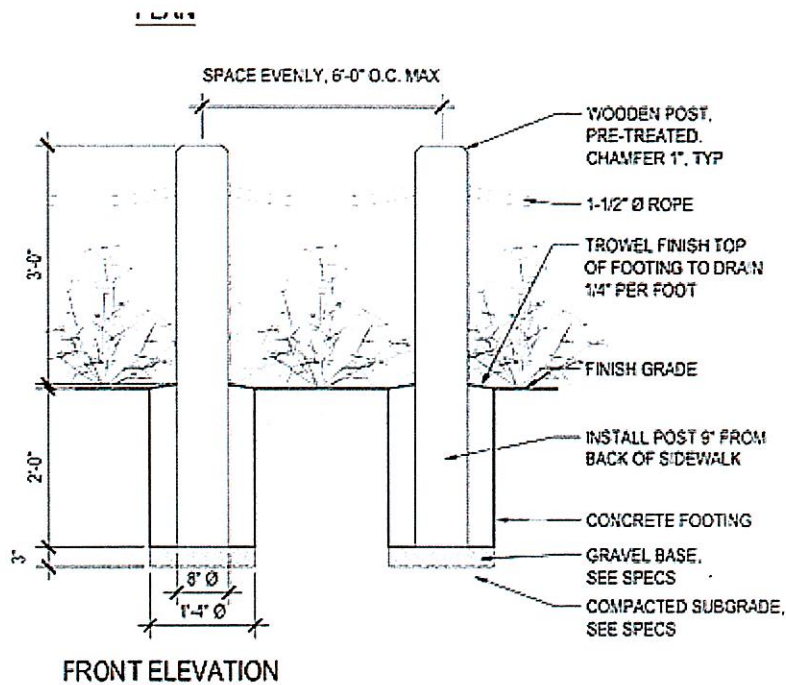

**5 ROPE BOLLARD FENCE**  
SCALE: 3/4" = 1'-0"

Thanks,



Ahmed Alnajm, MS | Estimating, Project Manager  
Bauman Landscape and Construction, Inc.  
2920 Lyon St., San Francisco, California 94123  
P:628.999.8394 Ext:108 C:279.204.3712

## Ahmed Alnajm

---

**From:** Ahmed Alnajm  
**Sent:** Wednesday, July 17, 2024 1:05 PM  
**To:** Chrisp Company Estimating  
**Cc:** Nakista Quiales; David Morris  
**Subject:** Ferry Landside Improvement Project

**Importance:** High

Hi,

Can you please send me a proposal for the Ferry Landside Improvement Project,\  
The due date will be 7/22/2024 , 2:00 pm

[Ferry Landside Improvement Project - COPS24-02531 \(2\)](#)

Thanks,



Ahmed Alnajm, MS | Estimating, Project Manager  
Bauman Landscape and Construction, Inc.  
2920 Lyon St., San Francisco, California 94123  
P:628.999.8394 Ext:108 C:279.204.3712

## Ahmed Alnajm

---

**From:** Ahmed Alnajm  
**Sent:** Wednesday, July 17, 2024 12:46 PM  
**To:** Shawn Byham  
**Subject:** RE: Ferry Landside Improvement Project

That's okay send me the price.  
the project we will bid on it 7/19/2024

**Ahmed Alnajm**  
Safety Manger and Estimator, Bauman Landscape &  
Construction



---

San Francisco, CA [www.baumanland.com](http://www.baumanland.com)  
 (415)447-4800 415-447-4800  
 [ahmed@baumanland.com](mailto:ahmed@baumanland.com)  
 100 Woodland Ave #200, San Rafael, CA 94901

---

**From:** Shawn Byham <[shawn@allstateutility.com](mailto:shawn@allstateutility.com)>  
**Sent:** Wednesday, July 17, 2024 12:43 PM  
**To:** Ahmed Alnajm <[ahmed@baumanland.com](mailto:ahmed@baumanland.com)>  
**Subject:** RE: Ferry Landside Improvement Project

IF I give you a submittal for JM pipe and sweeps, can you get that passed? We mainly stock JM, as they always have a better price

**From:** Ahmed Alnajm <[ahmed@baumanland.com](mailto:ahmed@baumanland.com)>  
**Sent:** Wednesday, July 17, 2024 12:22 PM  
**To:** [pasosales@allstateutility.com](mailto:pasosales@allstateutility.com)  
**Cc:** 'Shawn Byham' <[shawn@allstateutility.com](mailto:shawn@allstateutility.com)>  
**Subject:** Ferry Landside Improvement Project

Hi Shawn,

Can you provide me a price for these items below:

Project locations : 420 Litho Street, Sausalito, CA 94965 Project name : Ferry Landside Improvement Project

Due date : 7/19/2024 2:00pm

All the conduit will Sch 40 Catmex

1- 5" =520 LF  
Sweep 24" 5" = 4 EA  
5" CAP = 2 EA  
2- 4" =80 LF  
Sweep 24" 4" = 6 EA  
5" CAP = 3 EA  
3- 2" =220 LF  
Sweep 24" 2" = 6 EA  
2" CAP = 3 EA  
4-1.5" =140 LF  
Sweep 24" 5" = 2 EA

5- 1" = 600 LF  
PULL BOX = 5 EA N09 W/extension and lid  
1" 22.5 = 9 EA  
1" 45 DGREE = 4 EA

Ahmed Alnajm  
Safety Manger and Estimator, Bauman Landscape &  
Construction



---

 San Francisco, CA  [www.baumanland.com](http://www.baumanland.com)

 (415)447-4800  415-447-4800

 [ahmed@baumanland.com](mailto:ahmed@baumanland.com)

 100 Woodland Ave #200, San Rafael, CA 94901

---



Good Faith Efforts Documentation  
Page 2 of 3

- D. *Providing adequate information about plans, specifications and requirements in a timely manner to SBEs.*

List the names and dates of written notices sent to certified SBEs soliciting sub-bids for this project and the dates and methods used for following up initial solicitations to determine with certainty whether the SBEs were interested (**attach copies of written notices, solicitations, telephone records, fax confirmations, etc.**)

Names of SBEs Solicited	Date of Initial Solicitation	Follow Up Methods and Dates
<i>attached</i>		

- E. *Negotiating in good faith with SBEs.*

- F. *Not Rejecting SBEs as an unqualified firm without sound business reasons.*

List names of rejected SBEs and the reasons for the bidder's rejection of the SBEs and the firms selected for that work (attach copies of quotes from the firms involved):

Names of Rejected SBEs	Reasons for Rejection	Names of Selected Firms
<del>GATE</del> <i>Delco</i>	<i>price too high</i>	<i>CT Electric</i>

G. Making efforts to assist SBEs in obtaining required bonding, lines of credit, or insurance.

NO

H. Making efforts to assist SBEs in obtaining necessary equipment, supplies or materials.

IF needed yes

I. Effectively using the services of available minority/women community organizations; contractors groups; and local, state and federal assistance offices.

List the names of agencies, organizations or groups contacted to provide assistance in contacting, recruiting and using SBEs (attach copies of requests to agencies, organizations or groups and any responses received, i.e., lists, Internet page download, etc.).

Names of Agency/Organization/Group	Method/Date of Contact	Results
attached Emails		

J. Describe any other steps that the bidder used to solicit and select its SBEs.

\_\_\_\_\_  
\_\_\_\_\_

The undersigned certifies that the above narrative description is true and accurate, and may be relied upon by the City of Sausalito in evaluating the bidder's compliance with the solicitation requirements.

  
Signature of Owner or Authorized Representative

Comp. Secretary 7/25/20  
Title Date



**DBE/SBE CONFIRMATION OF PARTICIPATION IN CONTRACT**

This form is to be completed by each DBE/SBE owner whose sub-bid was accepted. Please make additional copies of form as necessary.

As a condition to the award of Contract No. 03.01.001, Ferry Landside Improvement Project  
*Contract # and Name*

I, Amela Bauman, do hereby confirm that  
*Name of DBE/SBE Owner*  
Bauman Landscape & const. will be  
*Name of DBE/SBE Firm*

performing/providing the following services:

General; concrete / sitework complete

The above services will be provided to Bauman  
*Name of Prime Contractor*

for the agreed upon dollar amount of \$ 200,000 approx. self performed

I declare under penalty of perjury that the foregoing statement is accurate and true.

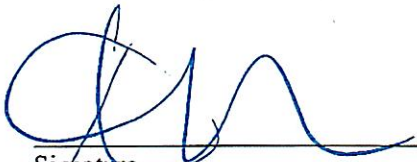
  
Signature

7/24/25  
Date



**INSTRUCTIONS – FINAL REPORT-UTILIZATION OF DISADVANTAGED BUSINESS ENTERPRISES (DBE) AND FIRST-TIER SUBCONTRACTORS**

1. **Local Agency Contract Number** - Enter the Local Agency contract number or identifier.
2. **Federal-Aid Project Number** - Enter the Federal-Aid Project Number.
3. **Local Agency** - Enter the name of the local or regional agency that is funding the contract.
4. **Contract Acceptance Date** - Enter the date the contract was accepted by the Local Agency.
5. **Contractor/Consultant** - Enter the contractor/consultant's firm name.
6. **Business Address** - Enter the contractor/consultant's business address.
7. **Final Contract Amount** - Enter the total final amount for the contract.
8. **Contract Item Number** - Enter contract item for work, services, or materials supplied provided. Not applicable for consultant contracts.
9. **Description of Work, Services, or Materials Supplied** - Enter description of work, services, or materials provided. Indicate all work to be performed by DBEs including work performed by the prime contractor/consultant's own forces, if the prime is a DBE. If 100% of the item is not to be performed or furnished by the DBE, describe the exact portion to be performed or furnished by the DBE. See LAMP Chapter 9 to determine how to count the participation of DBE firms.
10. **Company Name and Business Address** - Enter the name, address, and phone number of all subcontracted contractors/consultants. Also, enter the prime contractor/consultant's name and phone number, if the prime is a DBE.
11. **DBE Certification Number** - Enter the DBE's Certification Identification Number. Leave blank if subcontractor is not a DBE.
12. **Contract Payments** - Enter the subcontracted dollar amount of the work performed or service provided. Include the prime contractor/consultant if the prime is a DBE. If the materials or supplies are obtained from a DBE manufacturer, count 100% of the cost of the materials or supplies toward DBE goals. If the materials or supplies are purchased from a DBE regular dealer/supplier, count 60% of the cost of the materials or supplies toward DBE goals. The Non-DBE column is used to enter the dollar value of work performed by firms that are not certified DBE or for work after a DBE becomes decertified.
13. **Date Work Completed** - Enter the date the subcontractor/subconsultant's item work was completed.
14. **Date of Final Payment** - Enter the date when the prime contractor/consultant made the final payment to the subcontractor/subconsultant for the portion of work listed as being completed.
15. **Original DBE Commitment Amount** - Enter the "Total Claimed DBE Participation Dollars" from ~~ES~~ hG bid § 10-02 for the contract.
16. **Total** - Enter the sum of the "Contract Payments" Non-DBE and DBE columns.
17. **Contractor/Consultant Representative's Signature** - The person completing the form on behalf of the contractor/consultant's firm must sign their name.
18. **Contractor/Consultant Representative's Name** - Enter the name of the person preparing and signing the form.
19. **Phone** - Enter the area code and telephone number of the person signing the form.
20. **Date** - Enter the date the form is signed by the contractor's preparer.
21. **Local Agency Representative's Signature** - A Local Agency Representative must sign their name to certify that the contracting records and on-site performance of the DBE(s) has been monitored.
22. **Local Agency Representative's Name** - Enter the name of the Local Agency Representative signing the form.
23. **Phone** - Enter the area code and telephone number of the person signing the form.
24. **Date** - Enter the date the form is signed by the Local Agency Representative.

## MONTHLY PROMPT PAYMENT CERTIFICATION REPORT

Section 1708.5 of the California Business and Professions Code (CBPC) requires a prime contractor or subcontractor (i.e. builders) to pay any subcontractor not later than seven (7) days after receipt of each progress payment received or final retention payment. Section 3321 of the California Civil Code (CCC) requires prime design professionals (prime consultants directly in contract with a public agency) to pay any subcontractant not later than fifteen (15) days after receipt of each progress payment or final retention payment. The payment cannot be delayed because of disagreements on other contracts. Any delay or postponement of payment among the parties may take place only for good cause with the agency's prior written approval. This requirement applies to both DBE and non-DBE subcontractors.

### 1. CONTRACT INFORMATION

(1) Prime Contractor/Consultant	(2) Local Agency	(3) Federal Project Number	(4) Local Contract Number	(5) Total Contract Award Amt (\$)	(6) Total DBE Commitment Amt (\$)	(7) DBE Commitment (%)	(8) DBE Contract Goal (%)	(9) Reporting Period (MM/YYYY)

### 2. PAYMENT INFORMATION

(10) Subcontractor/Subconsultant Name	(11) DBE Cert. Number	(12) Subcontract Type	(13) Date Payment Received by Prime	(14) Date of Prime Payment to Sub	(15) Amount of Payment (\$)	(16) Amount Paid To Sub to Date (\$)	(17) Total Committed to This Subcontractor (\$)	(18) Promptly Paid? (Y/N)	(19) Incremental Retainage Paid? (Y/N)	(20) Comments or Reason for Non-Payment/Non-Prompt Payment, including Payment of Incremental Retainage*
<b>Totals:</b>					\$0	\$0	\$0			

List all first-tier subcontractors/subconsultants, whether or not the firms were originally listed in Exhibit 10-D2 or 15-G as a DBE commitment. If the actual DBE utilization was different than that approved at the time of award, provide comments in box (20). All payments reported, including payments to contractor/consultant, are for the date listed.  
\* Only reasons based on dispute on subcontractor or supplier noncompliance may be accepted.

### 3. CERTIFICATION

<p><b>The prime contractor or consultant hereby certifies that the foregoing Prompt Payment Certification Form is true and correct.</b></p> <p>(21) Prime Contractor Manager's Signature _____ (22) Date _____</p> <p>(25) Prime Contractor Manager's Name _____ (26) Phone _____</p>	<p><b>Local Agency certifies that all information in this form is complete and verified.</b></p> <p>(23) Local Agency Representative's Signature _____ (24) Date _____</p> <p>(27) Local Agency Representative's Name _____ (28) Phone _____</p>
---	--

\*The interactive MPP worksheet is additionally provided as the "Exhibit F – Monthly Prompt Payment Report" of the bid solicitation documents.

**END OF SPECIAL CONDITIONS**